

Technical data sheet for
Electric Chip Scuttle 450mm

CSLB8450E



CSLB8450E

CSLB8450E

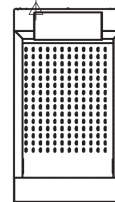
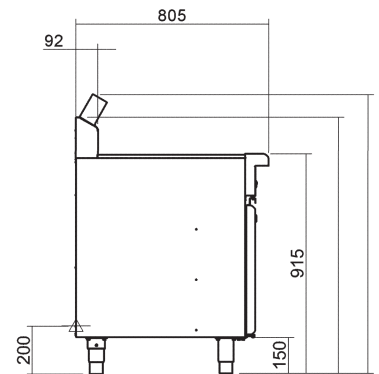
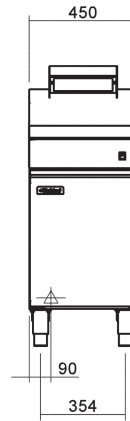

SPECIFICATIONS

Heating Elements

1 x 1kW ceramic infrared heater

Electrical Requirements

1kW, 220-240Vac, 50/60hz,

1P+N+E, 4.5A

3 pin 10A cordset fitted

Electrical Connection

90mm from RH side

200mm from floor

Water Connection

Cold water connection 184mm from

right hand side, 555mm from floor

R1/2 (BSP) male

550kPa 80psi maximum water

pressure

Dimensions

Width 450mm

Depth 805mm

Height 915mm

Incl. low back 1085mm

Incl. heater 1179mm

Nett weight

53kg nett

Packing data

0.58m³, 95kg

Width 490mm

Depth 865mm

Height 1350mm

OPTIONS AT EXTRA COST

Joining caps

Side splash guards

Castors

Plinth mounting

Series Options

CSLB - Low back models

CSB - 215mm splashback option



Australia moffat.com.au

New Zealand moffat.co.nz

In line with policy to continually develop and improve its products, Moffat Limited reserves the right to change specifications and design without notice.



ISO9001
 Quality
 Management
 Standard

an Ali Group Company



The Spirit of Excellence