

Technical data sheet for

# Icematic Ice Maker - Self Contained

## C46A ICE CUBES 35mm x 37mm x H 32mm, 20g

C46A



C46A

**SPECIFICATIONS**

**Dimensions**

Width: 500mm  
Depth: 540mm  
Height: 690mm

**Nett weight**

38kg

**Packed weight**

47kg

**Ice cube production dimension**

35mm x 37mm x H 32mm, 20g

**Water consumption**

Air cooled condensing unit: 3.8 litres per hour

**Electrical rating**

Air cooled version: 220-240V,1P+N+E, 50Hz

Compressor power rating: 1054W

Total absorbed power: 480W,

10A cordset fitted

**Refrigerant type**

R290

**Installation distance from wall**

Rear 150mm

Right 50mm

Left 150mm

Placement of unit should be indoors in an environment that does not exceed the air and water temperature limitations of the unit

**Water connection requirements**

Inlet connection: R 3/4"

Cold water (5-35°C)

Pressure (1-5 bar)

Water outlet connection: Ø 20mm

Note: 3m radius to any source of flame, combustion material or explosive material and ensure sufficient air circulation.



New Zealand [moffat.co.nz](http://moffat.co.nz)

In line with policy to continually develop and improve its products, Moffat Limited reserves the right to change specifications and design without notice.

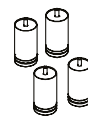
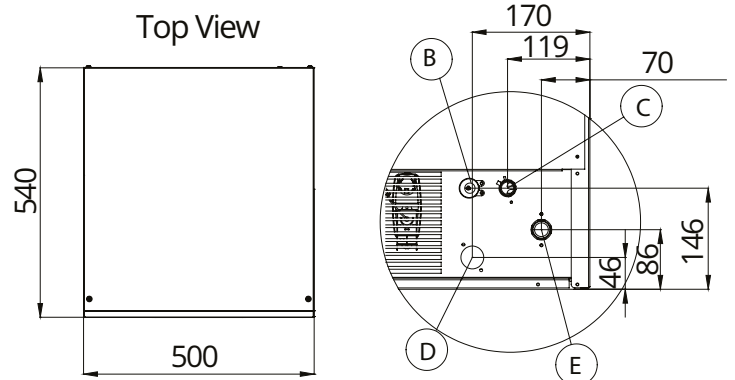
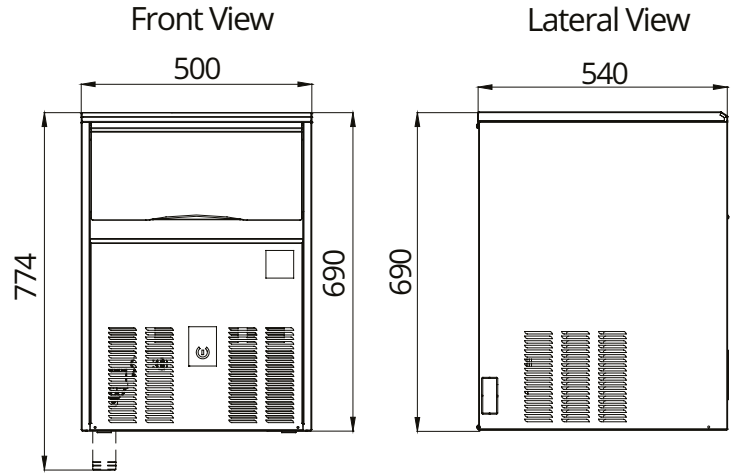

Kit 4 Feet Optional  
Ø 50 H 100 -120

- B. Electrical cable supply
- C. Water outlet connection Ø 20mm
- D. Water outlet connection water condensation Ø 20mm
- E. Water inlet connection - 3/4" gas

**Ice production per 24 hours**  
Water temperature

Ambient temperature	Water temperature					kg
	°C	32°	21°	15°	10°	
10°	34	41	45	46	kg	
21°	28	34	38	39	kg	
32°	26	32	36	37	kg	
38°	22	30	34	35	kg	