

Technical data sheet for

Icematic Ice & Water Dispenser - Countertop TD130A

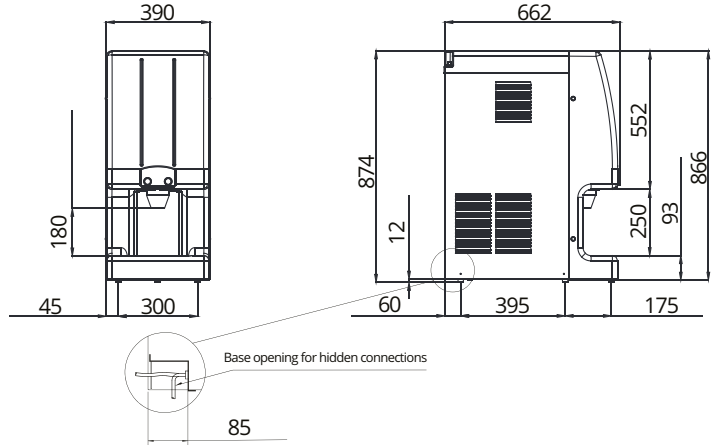

TD130A



TD130A

SPECIFICATIONS

Dimensions

Width: 390mm
Depth: 374mm
Height: 662mm

Nett weight

61kg

Packed weight

70kg

Water consumption

Air cooled version: 3.6 litres per hour

Electrical rating

Air cooled version: 230V, 1P+N+E, 50Hz
Compressor power rating 1200W
Total absorbed power 590W
10A cordset fitted

Refrigerant type

R134a

Installation distance from wall

Rear 150mm
Right 150mm
Left 150mm

Placement of unit should be indoors in an environment that does not exceed the air and water temperature limitations of the unit

Water connection requirements

Inlet connection: R 3/4"
Cold water (5-35°C)
Pressure (1-5 bar)
Water outlet connection: Ø 20mm

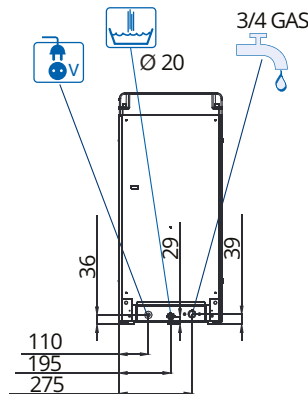

New Zealand moffat.co.nz

In line with policy to continually develop and improve its products, Moffat Limited reserves the right to change specifications and design without notice.



Ice production per 24 hours
Water temperature

| Ambient temperature | °C | | | | |
|---------------------|-----|-----|-----|-----|----|
| | 32° | 21° | 15° | 10° | |
| 10° | 119 | 127 | 131 | 136 | kg |
| 21° | 103 | 111 | 115 | 119 | kg |
| 32° | 78 | 86 | 90 | 94 | kg |
| 38° | 70 | 78 | 82 | 86 | kg |

© Copyright: Moffat Ltd NZ/ICE01.2024

an Ali Group Company



The Spirit of Excellence