

Technical data sheet for
ELECTRIC COOKTOPS 600mm
SEALED HOBS

RN8400SE-B, RN8400SE-LS, RN8400SE-CB



RN8400SE-LS

SPECIFICATIONS

Cooktop

2.6 kW Cast Iron Hot Plate elements

Electrical requirements

RN8400SE

10.4 kW, 400-415Vac, 50/60Hz,
 2P+N+E,
 22A/phase

Electrical connection

130mm from RH side, 30mm from rear

70mm from bench height on bench models

675mm from floor on leg stand and cabinet base models

Dimensions

Bench models

Width 600mm

Depth 805mm

Height 315mm

Incl. splashback 530mm

Incl. low back 370mm

All models (excluding Bench model)

Width 600mm

Depth 805mm

Height 915mm

Incl. splashback 1130mm

Incl. low back 970mm

Nett weight

Bench and Leg Stand models

74kg

Cabinet Base models

79kg

Packing data

Bench and Leg Stand models

0.37m³, 110kg

Width 645mm

Depth 870mm

Height 665mm

Cabinet Base models

0.70m³, 131kg

Width 870mm

Depth 645mm

Height 1255mm

RN8400SE-B Bench Model

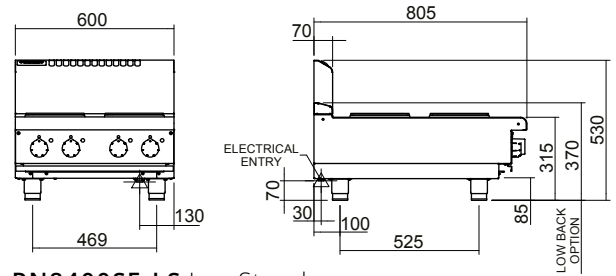

RN8400SE-LS Leg Stand

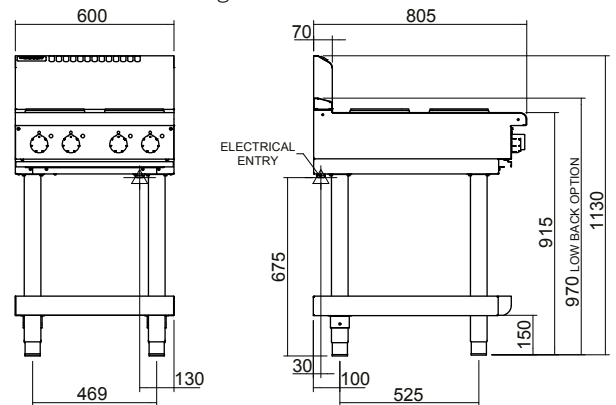

RN8400SE-CB Cabinet Base

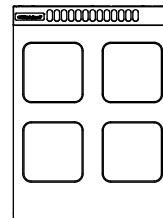
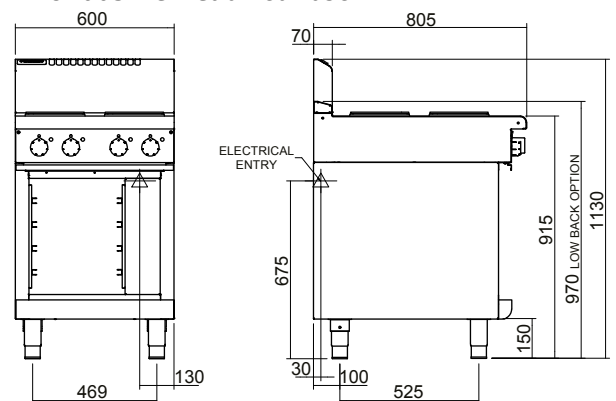

Australia moffat.com.au

New Zealand moffat.co.nz

In line with policy to continually develop and improve its products, Moffat Limited reserves the right to change specifications and design without notice.



ISO9001
 Quality
 Management
 Standard

an Ali Group Company



The Spirit of Excellence