

Technical data sheet for

# ELECTRIC RANGE CONVECTION OVEN 900mm SEALED HOBS

RN8610SEC

**Waldorf**  
800 SERIES



RN8610SEC

RN8610SEC

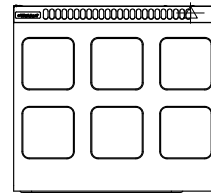
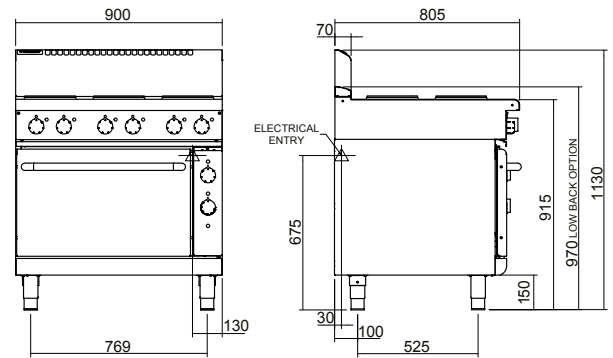

## SPECIFICATIONS

### Cooktop

2.6 kW Cast Iron Hot Plate elements

### Oven

4.5kW bottom heat element

2.0kW top heat element

Oven Fan Motor

100W

### Electrical requirements

RN8610SEC

22.2 kW max.

400-415Vac, 50/60Hz, 3P+N+E

L1 31.0A max.

L2 31.0A max.

L3 30.0A max.

### Oven Dimensions

Width 665mm

Depth 650mm

Height 400mm

Rack size 650mm x 600mm

Rack positions 4

### Electrical connection

130mm from RH side, 30mm from rear,

and 675mm from floor

### Dimensions

Width 900mm

Depth 805mm

Height 915mm

Incl. splashback 1130mm

Incl. low back 970mm

### Nett weight

198kg

### Packing data

1.03m<sup>3</sup>, 263kg

Width 945mm

Depth 870mm

Height 1255mm

### Options at extra cost

Joining caps

Castors

Plinth mounting

**MOFFAT**

Australia [moffat.com.au](http://moffat.com.au)

New Zealand [moffat.co.nz](http://moffat.co.nz)

In line with policy to continually develop and improve its products, Moffat Limited reserves the right to change specifications and design without notice.



ISO9001  
Quality  
Management  
Standard

an Ali Group Company



The Spirit of Excellence