

Technical data sheet for
**Target Top Gas Convection
 Oven Range 900mm** RNLB8110GC

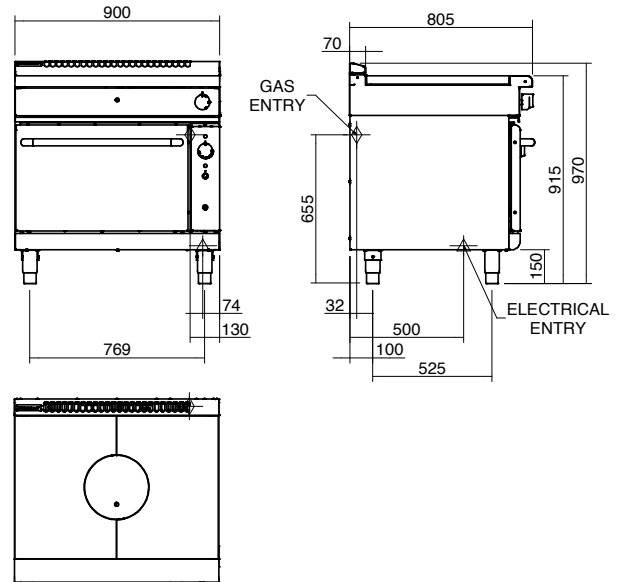

RNLB8110GC



RNLB8110GC

SPECIFICATIONS

Burners

45MJ dual ring cast iron - Target Top
 30MJ tubular - Oven

Gas power (gross)

75MJ/hr, 20.8kW

Oven Fan Motor

100W

Electrical requirements

0.13kW

230-240Vac, 50/60hz, 1P+N+E, 0.6A

Target Top

Cooking surface 900mm x 625mm,
 5625cm²

Centre 280mm diameter

Maximum plate temperature at
 centre 500°C

Oven Dimensions

Width 665mm

Depth 590mm

Height 385mm

Rack size 660mm x 540mm

Rack positions 4

Gas connection

R ³/₄ (BSP) male

130mm from RH side, 32mm from
 rear, and 655mm from floor

Optional underside connection (refer
 specification drawing)

All units supplied with Natural and
 LP gas regulator

Series Options

RNLB - Low back models

RNB - 215mm splashback option

Electrical connection

23mm from RH side, 484mm from
 rear, and 150mm from floor

Power cord with 10A 3 pin plug fitted

Dimensions

Width 900mm

Depth 805mm

Height 915mm

Incl. low back 970mm

Incl. splashback 1130mm

Nett weight

259kg

Packing data

1.03m³, 324kg

Width 945mm

Depth 870mm

Height 1255mm

Gas types

Available in Natural gas and LP gas

Please specify when ordering

Units supplied complete with gas
 type conversion kits

Other gas types on request

OPTIONS AT EXTRA COST

Joining caps

Castors

Plinth mounting



Australia moffat.com.au

New Zealand moffat.co.nz

In line with policy to continually develop and improve
 its products, Moffat Limited reserves the right to
 change specifications and design without notice.



ISO9001
 Quality
 Management
 Standard

an Ali Group Company



The Spirit of Excellence