

Technical data sheet for

# Electric Cooktops 600mm - Sealed Hobs

RNLB8400SE-B, RNLB8400SE-LS, RNLB8400SE-CD



RNLB8400SE-CD

## SPECIFICATIONS

### Cooktop

2.6kW Cast iron hot plate element

### Electrical requirements

RNLB8400SE

10.4 kW, 400-415Vac, 50/60Hz,

2P+N+E,

22A

### Electrical connection

130mm from RH side, 30mm from rear

70mm from bench height on bench models

675mm from floor on leg stand and cabinet base models

### Dimensions

#### Bench models

Width 600mm

Depth 805mm

Height 315mm

Incl. low back 370mm

Incl. splashback option 530mm

#### All models (excluding Bench model)

Width 600mm

Depth 805mm

Height 915mm

Incl. low back 970mm

Incl. splashback option 1130mm

### Nett weight

Bench and Leg Stand models

74kg

Cabinet Base models

79kg

### Packing data

Bench and Leg Stand models

0.37m<sup>3</sup>, 110kg

Width 645mm

Depth 870mm

Height 665mm

Cabinet Base models

0.70m<sup>3</sup>, 131kg

Width 645mm

Depth 870mm

Height 1255mm

RNLB8400SE-B

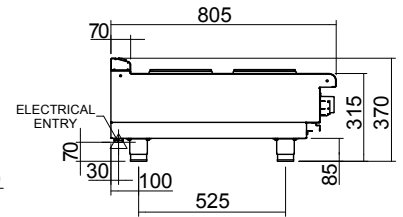
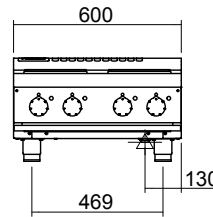

RNLB8400SE-LS

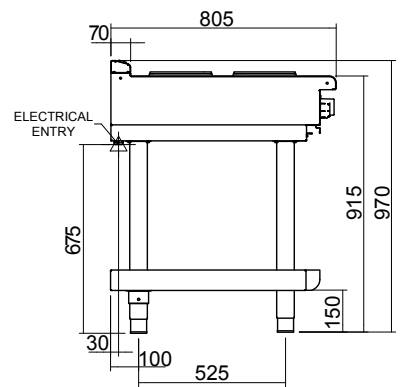
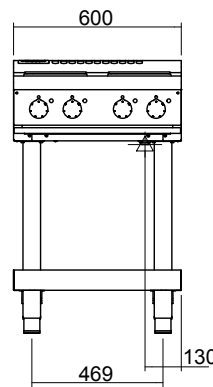

RNLB8400SE-CD

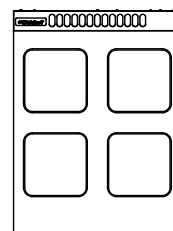
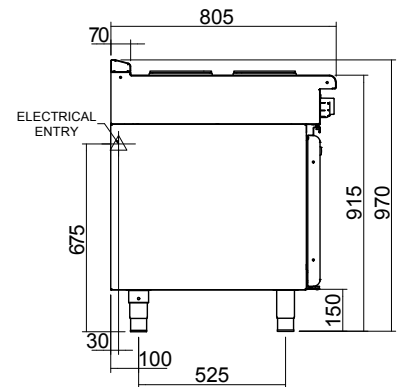
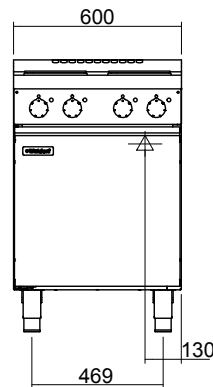

## Series Options

RNLB - Low back models

RNB - 215mm splashback option



Australia [moffat.com.au](http://moffat.com.au)

New Zealand [moffat.co.nz](http://moffat.co.nz)

In line with policy to continually develop and improve its products, Moffat Limited reserves the right to change specifications and design without notice.



ISO9001  
Quality  
Management  
Standard