

Technical data sheet for

# Gas Cooktops 900mm - 4 Burner

RNLB8900G-B, RNLB8900G-LS, RNLB8900G-CD, RNLB8900G-RB



RNLB8900G-CD

## SPECIFICATIONS

### Burners

28MJ/hr dual flame ring with simmer rate

### Gas power (gross)

112MJ/hr, 31kW

Gas connection

R ¾ (BSP) male

130mm from RH side, 32mm from rear, and 655mm from floor

All units supplied with Natural and LP gas regulator

### Refrigerated base

Type Ventilated system

Refrigerant R134a (160grams)

Climate classification T – tropical

Electrical connection

220-240Vac, 50Hz, 1.8A, 1P+N+E

3 pin 10A plug cordset fitted

### Dimensions

#### Bench models

Width 900mm

Depth 805mm

Height 315mm

Incl. low back 370mm

Incl. splashback option 530mm

#### All models (excluding Bench model)

Width 900mm

Depth 805mm

Height 915mm

Incl. low back 970mm

Incl. splashback option 1130mm

### Nett weight

Bench and Leg Stand models

129kg nett

Cabinet Base and Refrigerated Base models

180kg nett

### Packing data

Bench and Leg Stand models

0.55m<sup>3</sup>, 174kg

Width 945mm

Depth 870mm

Height 665mm

Cabinet Base and Refrigerated Base models

1.03m<sup>3</sup>, 245kg

Width 945mm

Depth 870mm

Height 1255mm

### Gas types

Available in Natural gas and LP gas

Please specify when ordering

Units supplied complete with gas type conversion kits

Other gas types on request

### OPTIONS AT EXTRA COST

Joining caps

Castors

Plinth mounting

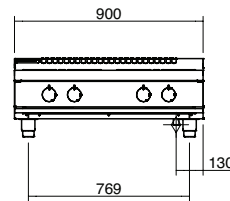

RNLB8900G-B

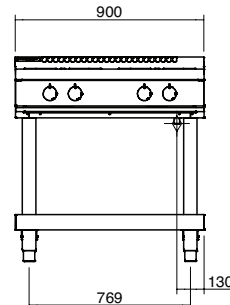
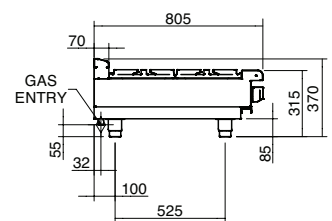

RNLB8900G-LS

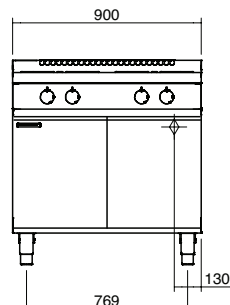
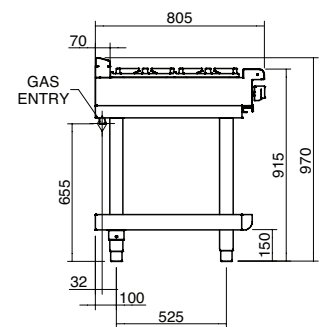

RNLB8900G-CD

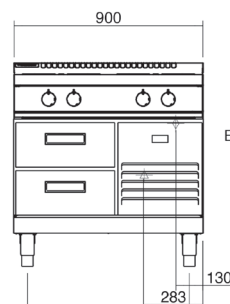
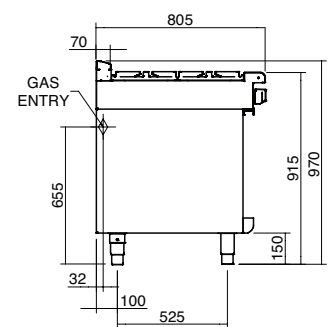

RNLB8900G-RB

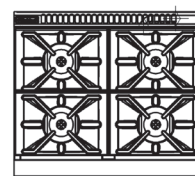
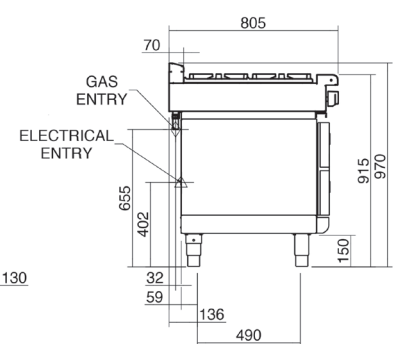

RNLB8900G



Australia [moffat.com.au](http://moffat.com.au)

New Zealand [moffat.co.nz](http://moffat.co.nz)

In line with policy to continually develop and improve its products, Moffat Limited reserves the right to change specifications and design without notice.



ISO9001  
Quality  
Management  
Standard

### Series Options

RNLB - Low back models

RNB - 215mm splashback option

an Ali Group Company



The Spirit of Excellence