

# Technical data sheet for Electric Salamander 900mm

SNB8200E

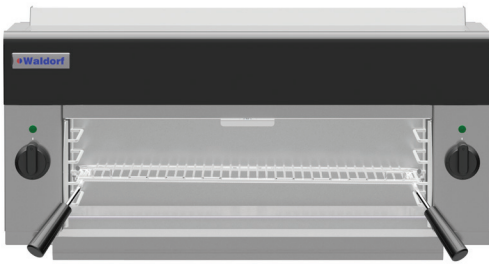

SNB8200E

SNB8200E

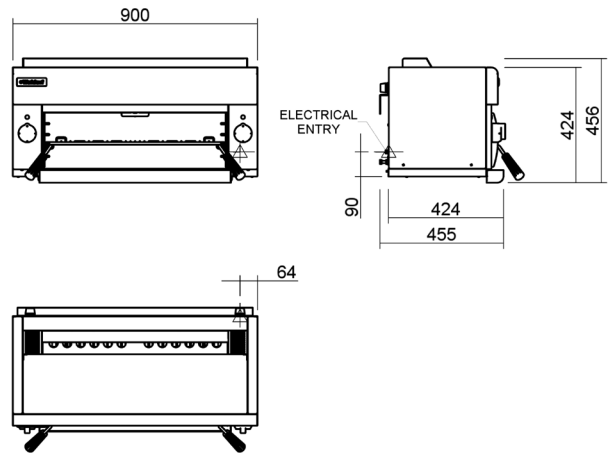

## SPECIFICATIONS

### Element

2 x 3kW

### Electrical requirements

230-240V, 1P+N+E, 50/60Hz, 6kW,  
25A

### Electrical connection

230-240V 1 phase hard wired via  
terminal block at back of unit 64mm  
from right side and 90mm from  
bottom of unit

### Dimensions

Width 900mm

Depth 424mm

(455mm with wall mounting bracket)

Height 456mm

### Cooking area

Rack size 610mm x 310mm,

1890cm<sup>2</sup>

Branding Plate 610mm x 310mm,

1890cm<sup>2</sup>

### Nett weight

36kg

### Packing data

0.31m<sup>3</sup>, 63kg

Width 945mm

Depth 520mm

Height 635mm

### OPTIONS AT EXTRA COST

100mm high feet for bench mounting

Branding kit - includes one double-  
sided, ribbed cast aluminium  
branding plate



Australia [moffat.com.au](http://moffat.com.au)

New Zealand [moffat.co.nz](http://moffat.co.nz)

In line with policy to continually develop and improve  
its products, Moffat Limited reserves the right to  
change specifications and design without notice.



ISO9001  
Quality  
Management  
Standard

an Ali Group Company



The Spirit of Excellence