



# Waldorf®

## 800 SERIES

Installation and Operation Manual

# 'Fast-Fri' Gas Fryer

FN8120G  
FN8226G  
FN8130G

FNL8120G  
FNL8226G  
FNL8130G

FNB8120G  
FNB8226G  
FNB8130G

FNLB8120G  
FNLB8226G  
FNLB8130G



\_\_\_\_\_

Date Purchased

\_\_\_\_\_

Serial Number

\_\_\_\_\_

Dealer

\_\_\_\_\_

Service Provider

\_\_\_\_\_

---

## MANUFACTURED BY

### Moffat Limited

Rolleston 7675  
New Zealand

## INTERNATIONAL CONTACTS

### AUSTRALIA

#### Moffat Pty Limited

**Web:** www.moffat.com.au  
**E.Mail:** vsales@moffat.com.au  
**Main Office:** (tel) +61 (03) 9518 3888  
(fax) +61 (03) 9518 3833  
**Service:** (tel): 1800 622 216  
**Spares:** (tel): 1800 337 963  
**Customer Service:** (tel): 1800 335 315  
(fax): 1800 350 281

### CANADA

#### Serve Canada

**Web:** www.servecanada.com  
**E.Mail:** info@servecanada.com  
**Sales:** (tel): 800 551 8795 (Toll Free)  
**Service:** (tel): 800 263 1455 (Toll Free)

### NEW ZEALAND

#### Moffat Limited

**Web:** www.moffat.co.nz  
**E.Mail:** sales@moffat.co.nz  
**Main Office:** (tel): 0800 663328

### UNITED KINGDOM

#### Blue Seal

**Web:** www.blue-seal.co.uk  
**E.Mail:** sales@blue-seal.co.uk  
**Sales:** (tel): +44 121 327 5575  
(fax): +44 121 327 9711  
**Spares:** (tel): +44 121 322 6640  
(fax): +44 121 327 9201  
**Service:** (tel): +44 121 322 6644  
(fax): +44 121 327 6257

### UNITED STATES

#### Moffat

**Web:** www.moffat.com  
**Sales:** (tel): 1-800 551 8795 (Toll Free)  
(tel): 336 661 1556  
(fax): 336 661 9546  
**Service:** (tel): 866 673 7937 (Toll Free)

### REST OF WORLD

#### Moffat Limited

**Web:** www.moffat.co.nz  
**E.Mail:** export@moffat.co.nz

---

The reproduction or copying of any part of this manual by any means whatsoever is strictly forbidden unless authorized previously in writing by the manufacturer.

In line with policy to continually develop and improve its products, Moffat Ltd. reserves the right to change the specifications and design without prior notice.

© Copyright Moffat Ltd. June 2024.

---

<b>FN(L)(B)8120G</b>	<b>'FAST FRI' GAS FRYER (Single Tank - 20 Ltr)</b>
<b>FN(L)(B)8226G</b>	<b>'FAST FRI' GAS FRYER (Twin Tank - 26 Ltr)</b>
<b>FN(L)(B)8130G</b>	<b>'FAST FRI' GAS FRYER (Single Tank - 31 Ltr)</b>

<b>Introduction .....</b>	<b>2</b>
<b>Specifications .....</b>	<b>3</b>
Model Numbers Covered in this Specification	
Gas Supply Requirements	
<b>Dimensions .....</b>	<b>5</b>
<b>Installation .....</b>	<b>6</b>
Installation Requirements	
Unpacking	
Location	
Clearances	
Assembly	
Fitting Rear Rollers	
Gas Connection	
Commissioning	
<b>Operation.....</b>	<b>11</b>
Operation Guide	
Description of Controls	
Filling the Tank(s)	
Lighting Pilot Burners	
Lighting Main Burners	
Setting the Operating Temperature	
Turning 'OFF' the Fryer	
<b>Cleaning and Maintenance .....</b>	<b>15</b>
General	
Draining and Daily Cleaning	
Weekly Cleaning	
Periodic Maintenance	
<b>Fault Finding.....</b>	<b>18</b>
Guide to Cooking Problems with the Fryer	
Fault Finding the Gas System	
<b>Wiring Schematics.....</b>	<b>21</b>
<b>Gas Supply Connection Location Conversion .....</b>	<b>23</b>
<b>Gas Conversion and Specifications .....</b>	<b>24</b>
Conversion Procedure	
Gas Specifications	
<b>Replacement Parts List.....</b>	<b>28</b>

---

## Introduction

---

We are confident that you will be delighted with your Waldorf 'Fast Fri' Gas Fryer, and it will become a most valued appliance in your commercial kitchen.

To ensure you receive the utmost benefit from your new Waldorf 'Fast Fri' Gas Fryer, there are two important things you can do:-

### Firstly:

Please read the instruction book carefully and follow the directions given. The time taken will be well spent.

### Secondly:

If you are unsure of any aspect of the installation, instructions or performance of your appliance, contact your WALDORF dealer promptly. In many cases a phone call could answer your question.

### CE Only:

These instructions are only valid if the country code appears on the appliance. If code does not appear on appliance, refer to supplier of this appliance to obtain technical instructions for adapting appliance to conditions for use in that country.



#### Warning

**IMPROPER INSTALLATION, ADJUSTMENT, ALTERATION, SERVICE OR MAINTENANCE CAN CAUSE PROPERTY DAMAGE, INJURY OR DEATH. READ THE INSTALLATION, OPERATING AND MAINTENANCE INSTRUCTIONS THOROUGHLY BEFORE INSTALLING OR SERVICING THIS APPLIANCE.**



#### Warning

**INSTRUCTIONS TO BE FOLLOWED IN THE EVENT THE USER SMELLS GAS ARE TO BE POSTED IN A PROMINENT LOCATION. THIS INFORMATION SHALL BE OBTAINED BY CONSULTING THE LOCAL GAS SUPPLIER.**



#### Warning

**GREAT CARE MUST BE TAKEN BY THE OPERATOR TO USE THE EQUIPMENT SAFELY TO GUARD IT AGAINST RISK OF FIRE.**

- **THE APPLIANCE MUST NOT BE LEFT ON UNATTENDED.**
- **IT IS RECOMMENDED THAT A REGULAR INSPECTION IS MADE BY A COMPETENT SERVICE PERSON TO ENSURE CORRECT AND SAFE OPERATION OF YOUR APPLIANCE IS MAINTAINED.**
- **DO NOT STORE OR USE GASOLINE OR OTHER FLAMMABLE VAPOURS OR LIQUIDS IN THE VICINITY OF THIS OR ANY OTHER APPLIANCE.**
- **DO NOT SPRAY AEROSOLS IN THE VICINITY OF THIS APPLIANCE WHILE IT IS IN OPERATION.**



#### Caution

- **This appliance is for professional use and is only to be used by qualified persons.**
- **Only authorised service persons are to carry out installation, servicing or gas conversion operations.**
- **Components having adjustments protected (e.g. paint sealed) by the manufacturer should not be adjusted by the user / operator.**
- **DO NOT operate the appliance without the legs supplied fitted.**

## Model Numbers Covered in this Specification

**FN[1]8120G 'FAST FRI' GAS FRYER (Single Tank - 20 Ltr)**

**FN[1]8226G 'FAST FRI' GAS FRYER (Twin Tank - 26 Ltr)**

**FN[1]8130G 'FAST FRI' GAS FRYER (Single Tank - 31 Ltr)**

**NOTE:**

[1]: - Model Options;

- - Standard.
- L - Low Back.
- B - Bold Front.
- LB - Low Back and Bold Front.

## Gas Supply Requirements

**- Australia:**

	Natural Gas	LP Gas (Propane)
<b>Input Rating (N.H.G.C.)</b>	90 MJ/hr	90 MJ/hr
<b>Supply Pressure</b>	1.13 - 2.00 kPa	2.75 - 3.00 kPa
<b>Burner Operating Pressure (*)</b>	0.98 kPa	2.50 kPa
<b>Gas Connection</b>	¾" BSP Male	

**- New Zealand:**

	Natural Gas	LP Gas
<b>Input Rating (N.H.G.C.)</b>	90 MJ/hr	80 MJ/hr
<b>Supply Pressure</b>	1.13 - 2.00 kPa	2.75 - 3.00 kPa
<b>Burner Operating Pressure (*)</b>	0.98 kPa	2.50 kPa
<b>Gas Connection</b>	¾" BSP Male	

**- United Kingdom & EU (CE)**

Category: **II<sub>2H3P</sub>(20. 37), II<sub>2H3B/P</sub>(20, 28-30),**

Flue Type: **A<sub>1</sub>.**

	Natural Gas (G20)	Propane (G31)	LP Gas (G30-G31)
<b>Heat Input (nett)</b>	22.5 kW	22.5 kW	24.2 kW
<b>Gas Rate</b>	2.26 m <sup>3</sup> /hr	1.75 kg/hr	1.91 kg/hr
<b>Supply Pressure</b>	20 mbar	37 mbar	28-30 mbar
<b>Burner Operating Pressure (*)</b>	9.8 mbar	25 mbar	
<b>Gas Connection</b>	¾" BSP Male		

**NOTE: (\*) Measure burner operating pressure at Lower Test Point (Out) on gas control valve with both burners operating at the 'High Flame' setting. Refer to 'Gas Conversion and Specification' Section for further details.**

# Specifications

---

**- All Other Markets:**

		<b>Natural Gas</b>	<b>Town Gas (**)</b>
<b>Input Rating (N.H.G.C.)</b>		90 MJ/hr	90 MJ/hr
<b>Supply Pressure</b>	<b>Non-CE models</b>	1.13 - 2.0 kPa	0.75 - 1.5 kPa
	<b>CE models</b>	25 mbar	N/A
<b>Burner Operating Pressure (*)</b>		0.98 kPa	0.5 kPa
<b>Gas Connection</b>		3/4" BSP Male	

		<b>LP Gas (Propane)</b>	<b>Butane</b>
<b>Input Rating (N.H.G.C.)</b>		90 MJ/hr	90 MJ/hr
<b>Supply Pressure</b>	<b>Non-CE models</b>	2.75 - 3.0 kPa	2.75 - 3.0 kPa
	<b>CE models</b>	37 mbar	37 mbar
<b>Burner Operating Pressure (*)</b>		2.5 kPa	2.5 kPa
<b>Gas Connection</b>		3/4" BSP Male	

**NOTE:**

- (\*) Measure burner operating pressure at Lower Test Point (Out) on the gas control valve, with both burners operating at 'High Flame' setting.
- (\*\*) TOWN GAS Option is only available with specific ex-factory built Town Gas models, which can also be converted to any other gas. Standard models can only be converted between Nat. Gas, LP Gas and Butane, but not Town Gas.
- Refer to 'Gas Conversion and Specifications' section of this manual for further details.

## FN(L)8120G / FN(L)8226G - GAS FRYERS

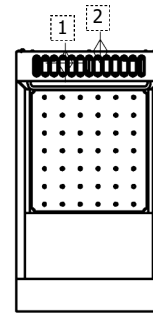
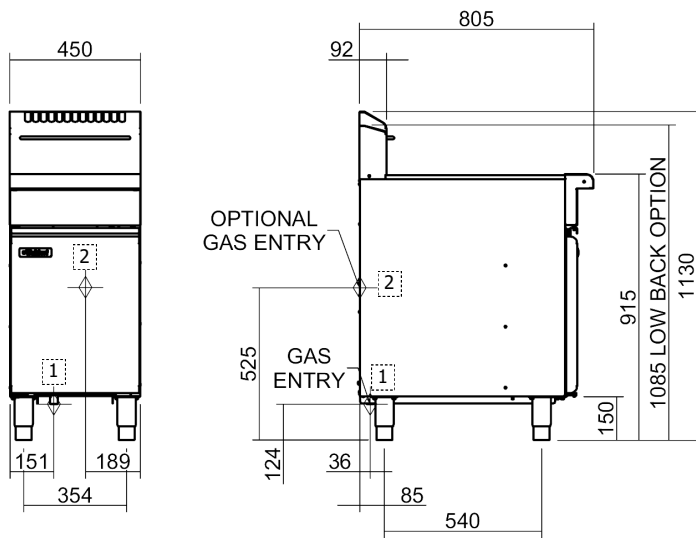

**FN(L)8120G  
Single Tank**

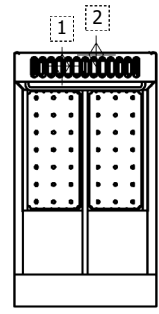

**FN(L)8226G  
Twin Tank**



- 1.** Primary Gas Entry Point.
- 2.** Optional Gas Entry Point.

## FN(L)8130G - GAS FRYER

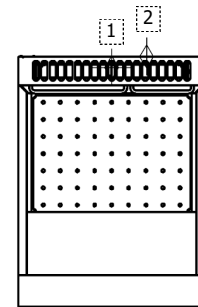
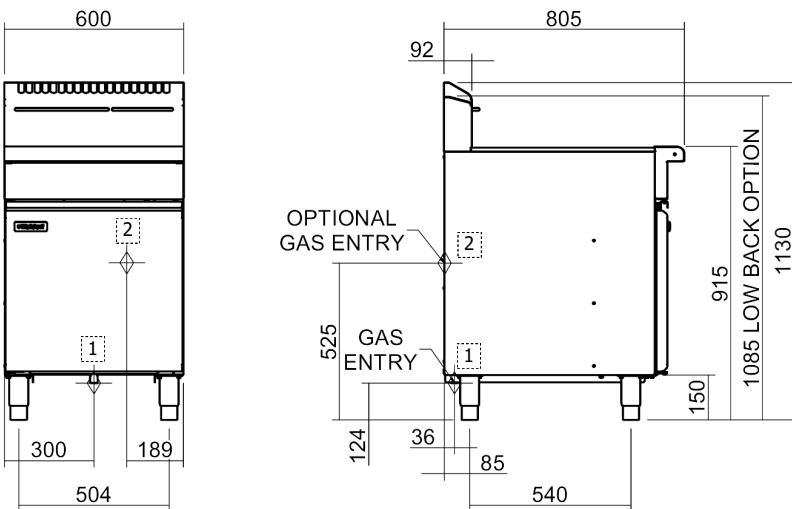

**FN(L)8130G  
Single Tank**



- 1.** Primary Gas Entry Point.
- 2.** Optional Gas Entry Point.

# Installation

---

## Installation Requirements

### NOTE:

- **It is most important that this appliance is installed correctly and that operation is correct before use. Installation shall comply with local, gas, health and safety requirements.**
- **This appliance shall be installed with sufficient ventilation to prevent occurrence of unacceptable concentrations of health harmful substances in room, the appliance is installed in.**

Waldorf 'FAST FRI' Gas Fryers are designed to provide years of satisfactory service and correct installation is essential to achieve the best performance, efficiency and trouble-free operation.

This appliance must be installed in accordance with National installation codes and in addition, in accordance with relevant National / Local codes covering gas and fire safety.

**Australia / New Zealand:** AS 5601.1 - Gas Installations.

**United Kingdom:** Gas Safety (Installation and Use) Regulations 1998.

**Ireland:** IS 820 - Non Domestic Gas Installations.

**Installations must be carried out by qualified service persons only. Failure to install equipment to relevant codes and manufacturer's specifications shown in this section will void the warranty.**

**Components having adjustments protected (e.g. paint sealed) by manufacturer, are only to be adjusted by an authorised service agent. They are not to be adjusted by the installation person.**

## Unpacking

- Remove all packaging and transit protection from appliance including all protective plastic coating from door outer panel and exterior stainless steel panels.
- Check equipment and parts for damage. Report any damage immediately to carrier and distributor.
- Report any deficiencies to distributor who supplied appliance.
- Check available gas supply is correct to that shown on rating plate located on inside of access door.
- Check the following parts have been supplied with appliance:

	<b>FN8120G</b>	<b>FN8226G</b>	<b>FN8130G</b>
Baskets	2	2	3
Basket Trays	1	2	1
Lid	1	1	1
Drain Stick	1	1	1

## Location

1. This appliance must be installed in a suitably ventilated room to prevent dangerous build up of combustion products.
2. Installation must allow for a sufficient flow of fresh air for combustion air supply. Combustion air requirements:-

### **Combustion Air Requirements**

**All Gas Types 24 m<sup>3</sup>/hr minimum.**

3. Position appliance in its approximate working position.
4. All air for burner combustion is supplied from beneath the appliance. Legs must always be fitted and no obstructions placed beneath or around the base of the appliance, as obstructions will cause incorrect operation and / or failure of appliance.

**NOTE: Do not obstruct or block the appliances flue. Never directly connect a ventilation system to the appliance flue outlet.**



## Clearances

### NOTE:

- **Only non-combustible materials can be used in close proximity to this appliance.**
- **To facilitate easy operation, drainage and servicing of appliance, a minimum of 600mm clearance should be maintained at front of appliance.**

Any gas burning appliance requires adequate clearance and ventilation for optimum and trouble-free operation. The following minimum installation clearances are to be adhered to:

	<b>Combustible Surface</b>	<b>Non Combustible Surface</b>
Left / Right Hand Side	50mm	0mm
Rear	50mm	0mm

## Assembly

This model is delivered completely assembled. Ensure that legs are securely attached.

### NOTE:

- **This appliance is fitted with adjustable feet to enable it to be positioned securely and level on uneven floors. This should be carried out on completion of gas connection. Refer to 'Gas Connection' on the following pages.**
- **This appliance can also be fitted with rear rollers to enable appliance to be easily moved for positioning and cleaning purposes. If desired, these rollers are supplied in the packaging, with the appliance. See overleaf for fitting instructions.**

## Optional Accessories (Refer to Replacement Parts List)

- Plinth Kit. For installation details, refer to instructions supplied with each kit.

# Installation

## Fitting Rear Rollers.

1. Raise appliance from floor by approx. 75mm using suitable lifting equipment (i.e. Palletiser / Forklift) to allow rear adjustable feet to be removed.
2. Unscrew and remove both rear adjustable feet from rear leg housings.
3. Fit rear roller to rear leg housing and align screw hole in side of rear leg housing with threaded hole in rear roller.
4. Secure rear roller to leg support with bolt supplied and tighten bolt.
5. Fit second roller and tighten.
6. Lower appliance back to floor and adjust front adjustable feet to level appliance.

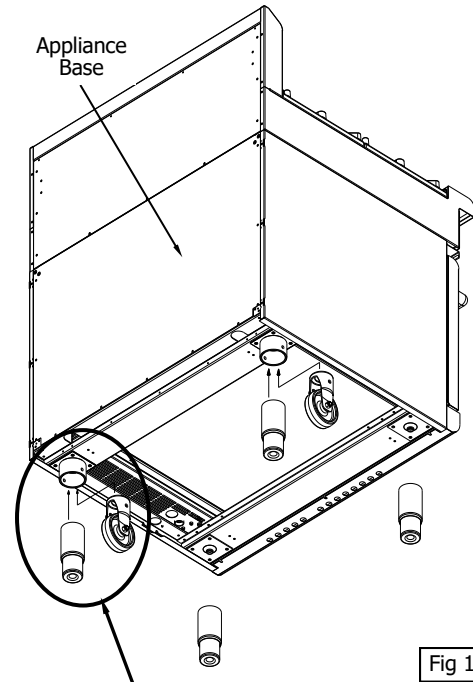
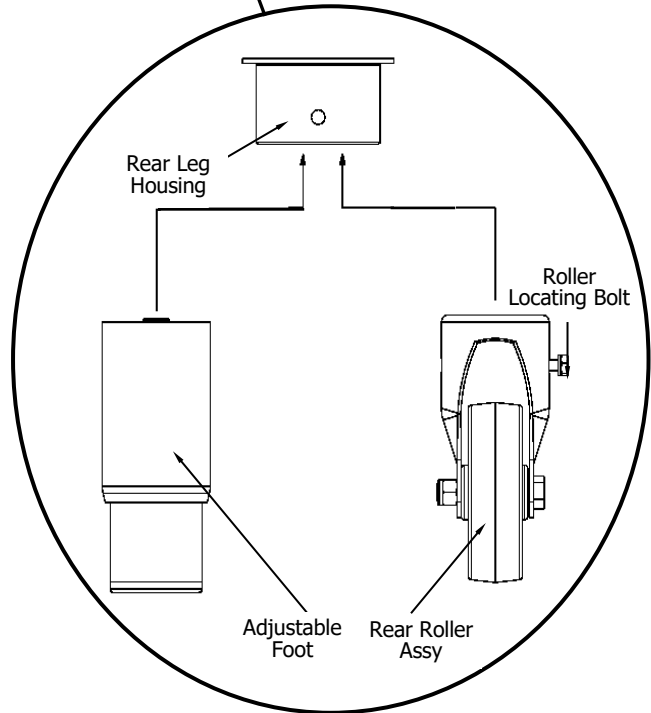

Fig 1



## Gas Supply Connection

**NOTE: ALL GAS FITTING MUST ONLY BE CARRIED OUT BY A QUALIFIED SERVICE PERSON.**

This appliance can be configured to have underside or rear entry gas supply.

To convert this appliance, see the Gas Supply Connection Location Conversion section of this manual for instructions.

## Flexible Hose Connection

If a Gas Hose assembly is used to connect this appliance, hose and all fittings must have a minimum  $\frac{3}{4}$ " (Natural Gas) or  $\frac{1}{2}$ " (LPG) inside bore diameter to ensure gas flow rate capacity required by this appliance is achieved.

This must be verified by operating pressure testing at maximum gas supply demand condition.

Gas Hose assembly should also be classified for use in commercial kitchen conditions that appliance will be used in.

Recommended Gas Hose Assembly Specification:

- AS/NZS 1869 Class B or D compliant or equivalent, that meets the following requirements:-

Class	Max Working Pressure at $23 \pm 2^\circ\text{C}$	Working Temperature Range	Resistance to Oil
B	7.0 kPa	- 20°C to + 125°C	Oil resistant lining and cover.
D	2.6 MPa		

1. Waldorf FN8120G / FN8226G / FN8130G Fryers do not require an electrical connection, they function totally on gas supply only.

**NOTE: ALL GAS FITTING MUST ONLY BE CARRIED OUT BY A QUALIFIED SERVICE PERSON.**

2. It is essential that gas supply is correct for appliance to be installed and that adequate supply pressure and volume are available. The following checks should be made before installation:-
  - a. **Gas Type** the appliance has been supplied for is shown on a coloured sticker located above the gas entry point and next to the rating plate. Check that this is correct for gas supply the appliance is being installed for. Gas conversion procedure is shown in this manual.
  - b. **Supply Pressure** required for this appliance is shown in Specifications section of this manual. Check gas supply to ensure that adequate supply pressure exists.
  - c. **Input Rate** of this appliance is shown on Rating Plate fitted to inside of access door and in Specifications section of this manual. Input rate should be checked against available gas supply line capacity. **Particular note should be taken if the appliance is being added to an existing installation.**



**NOTE: It is important that adequately sized piping runs directly to the connection joint on the appliance, with as few tees and elbows as possible to give maximum supply volume.**

3. A suitable joining compound which resists the breakdown action of LPG must be used on every gas line connection, unless compression fittings are used.

Connection to appliance is  $\frac{3}{4}$ " BSP male.

**NOTE: A Manual Isolation Valve must be fitted to individual appliance supply line.**

4. Correctly locate the appliance into its final operating position and, using a spirit level, adjust legs so that unit is level and at the correct height.
5. Connect gas supply to the appliance.
6. Check all gas connections for leakages using soapy water or other gas detecting equipment.



### Warning

**DO NOT USE A NAKED FLAME TO CHECK FOR GAS LEAKAGES.**

## Installation

7. Check gas supply pressure is as shown in Specifications section, **Gas Supply Requirements** table.

**NOTE:** Measure supply pressure at upper test point (Supply Pressure) on gas control valve.



### Caution

**Ensure the fryer tank(s) is are filled with either water or oil prior to starting Main Burners otherwise damage may be caused to fryer tank(s).**

8. Light Pilot Burners. Refer to **Operation** section, **Lighting Pilot Burners**.
9. Check pilot flame size. Re-adjust if required, using pilot adjusting screw (See Fig 3 below), and as shown in **Gas Conversion and Specifications** section, **Pilot Burner Flame Adjustment**.
10. Light Main Burners. Refer to **Operation** section, **Lighting Main Burners**.
11. Verify supply pressure is still correct.
12. Check Main Burner operating pressure (Adjust, using **Operating Pressure Adjusting Screw** on Gas Control Valve, see Fig 3), and as shown in **Gas Conversion and Specifications** section, **Main Burner Operating Pressure Adjustment**.

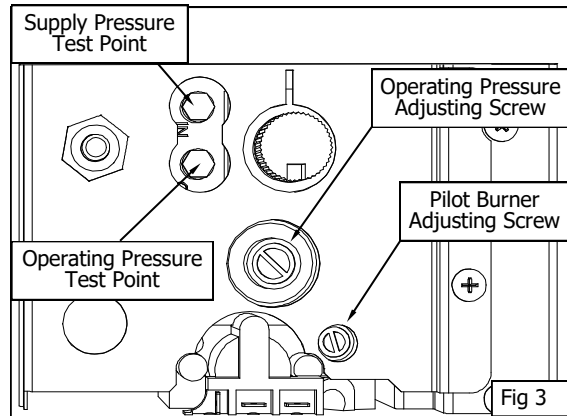

**NOTE:** Insufficient gas supply line capacity, indicated by operating pressure drop during maximum gas supply demand, is **NOT ACCEPTABLE** and may invalidate manufacturers warranty for this appliance.

## Commissioning

**Carry out the following commissioning checks before handing over the fryer for use, to ensure that fryer operates correctly and operator(s) understand correct operating procedure.**

1. Before leaving the new installation;
  - a. Check the following functions in accordance with operating instructions specified in **Operation** section of this manual.
    - Light the Pilot Burners.
    - Light the Main Burners.
    - Check the Thermostat Operation (refer to **Operation** section of this manual).
  - b. Thermostat operation check should be carried out by filling fryer with oil / shortening to oil **FILL LEVEL** mark at rear of tank (refer to **Filling the Tank** in **Operation Section** of Manual) and setting thermostat to 180°C. Light pilot burners and turn **On** main burners in accordance with **Operation Instructions** in this manual.
  - c. Once oil is up to temperature, check thermostat calibration. If a discrepancy is found, thermostat calibration should be referred to the supplier.
  - d. Ensure each operator has been instructed in areas of correct lighting, operation, and shutdown procedures for appliance.

### Initial Start-Up

- a. For first time use of fryer, prior to using fryer for cooking product, fill fryer tank with oil and operate for about 1 hour at **Full Flame** setting to remove any fumes or odours which may be present from the new appliance.
  - b. Refer to the Operation Section of this manual for details on how to operate the fryer.
2. This manual must be kept by the owner for future reference and a record of **Date of Purchase**, **Date of Installation** and **Serial Number of Unit** recorded and kept with this manual. **(These details can be found on Rating Plate attached to rear of access door. Refer to Figure 2 in 'Gas Connection' section).**

**NOTE:** If for some reason it is not possible to get appliance to operate correctly, shut Off gas supply and contact supplier of this unit.

## Operation Guide



### Warning

**GREAT CARE MUST BE TAKEN BY OPERATOR, TO USE THE FRYER SAFELY, TO GUARD AGAINST RISK OF INJURY AND FIRE.**

- **DO NOT LEAVE FRYER UN-ATTENDED DURING OPERATION.**
- **DO NOT REPLENISH THE OIL (FRYING MEDIUM) IN THE FRYER WHEN THE FRYER IS HOT.**
- **DO NOT OVER FILL THE OIL (FRYING MEDIUM) IN THE FRYER ABOVE THE TOP LEVEL MARK.**
- **DO NOT ALLOW THE OIL (FRYING MEDIUM) IN THE FRYER TO FALL BELOW THE LOWER LEVEL MARK.**
- **DO NOT ALLOW THE OIL (FRYING MEDIUM) IN THE FRYER TO OVERHEAT.**
- **DO NOT INTRODUCE WET FOOD OR WATER INTO THE HOT OIL (FRYING MEDIUM).**
- **DO NOT USE FLAMMIBLE SOLVENTS AND CLEANING AIDS ON OR IN CLOSE PROXIMITY TO THE FRYER WHILST THE FRYER IS STILL HOT.**



### Caution

- **This appliance is for professional use and is only to be used by qualified persons.**
- **Only authorised service persons are to carry out installation, servicing or gas conversion operations.**
- **Components having adjustments protected (e.g. paint sealed) by the manufacturer should not be adjusted by the user / operator.**

## Description of Controls

- (FN8120G Illustrated)

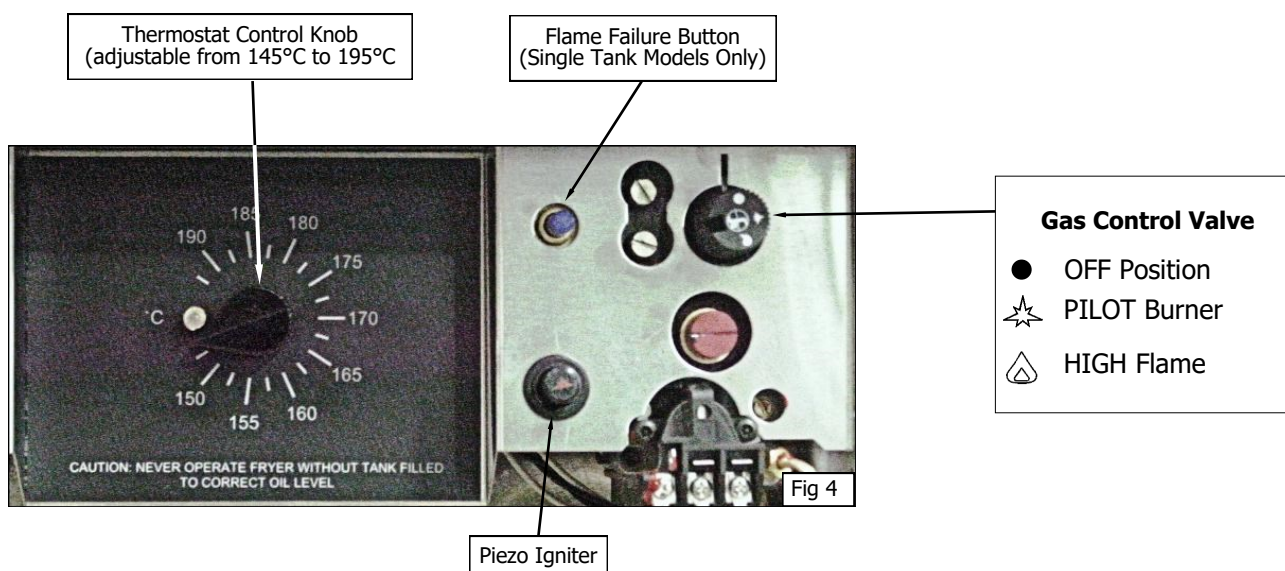

## Operation



### Warning

THE FLUE OUTLET AREA IS A HIGH TEMPERATURE HIGHLY FLAMMABLE AREA

**DO NOT BANG, SHAKE OR HOLD FRYER BASKETS IN THE FLUE OUTLET AREA - THIS IS A HIGH RISK AREA FOR FLAMMABLE MATERIAL (e.g. OIL / FAT AND DEBRIS FROM BASKETS COULD IGNITE HERE).**

High Temperature Flue Area

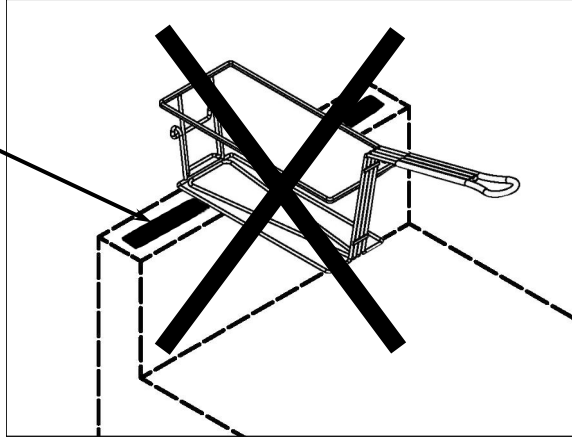

### Filling the Tank(s)



### Warning

**DANGER OF FIRE EXISTS IF THE OIL LEVEL IS BELOW THE MINIMUM 'LO' INDICATED LEVEL.**

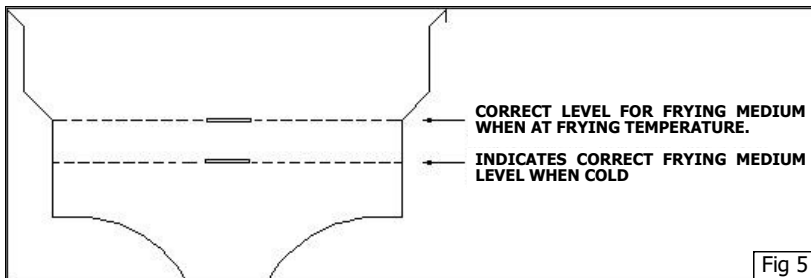

**NOTE: WALDORF 'FAST-FRI' fryers can be used with both oil and shortening.**

1. Before filling the tank, always check that the drain valve(s) behind the access door is (are) closed. A locking slide is provided on these valves, this should always be locked in position during use.

**OIL** - Carefully fill the fryer tank(s) with oil to the lower 'FILL LEVEL' mark shown at the rear of the tank. Set the thermostat to the required operating temperature, the oil will expand as heated and will reach the upper level marked when the oil is hot (180 - 190°C).

- FN8120G fryer will hold 20 litres of oil.
- FN8226G fryer will hold 13 litres of oil per tank.
- FN8130G fryer will hold 31 litres of oil.

**SHORTENING** - Ideally shortening should be pre-melted prior to putting it into the tank. This is normally done in a suitable vessel on a boiling table burner(s). The liquefied shortening can then be poured into the tank until it reaches the 'FILL LEVEL' mark.

- FN8120G fryer will hold 37 lbs shortening.
- FN8226G fryer will hold 24 lbs shortening per tank.
- FN8130G fryer will hold 46.5 lbs shortening.

## Pre-Heating

**NOTE: When pre-melting shortening, only heat the shortening until it is just liquefied. Do not bring the shortening up to high temperature as handling of hot shortening is dangerous.**

- If pre-melting of shortening is not possible, carefully cut the shortening in to small pieces and pack into the tank.
- Light main burners and manually cycle burners **On/Off** until shortening has liquefied. Ideally main burners should be cycled **On** for 5 seconds and **Off** for 10 seconds. Repeat cycle until all shortening is melted. Following this procedure should allow shortening to liquefy gradually without scorching. Once shortening has liquefied, it can be brought up to fryer operating temperature.
- To speed up this process, break up shortening and stir carefully during melting process. Add more shortening until tank is filled to the level marked on the tank side. Refer to Fig 5 above.

**NOTE: Running burners continuously will cause shortening in contact with the tank to overheat, resulting in premature oil breakdown. Never allow shortening to smoke while melting as this indicates that the temperature is too high. If shortening starts smoking, increase main burner 'Off' intervals.**

## Lighting Pilot Burners

### **FN8120 Fryer (Single Tank)**

1. Rotate gas control knob to **Pilot** position and hold knob depressed.
2. At the same time hold flame failure button depressed.
3. Depress piezo igniter until right hand pilot ignites.
4. Hold gas control knob and flame failure button depressed for approx. 10 to 15 seconds after igniting pilot burner, then release, both pilot burners should remain alight.
5. If pilot burners do not ignite, repeat Items 1 to 4 above.

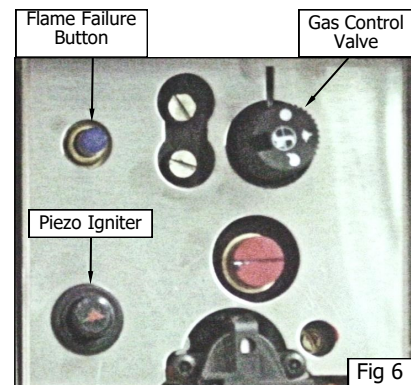

### **FN8130 Fryer (Single Tank)**

1. Rotate gas control knob to **Pilot** position and hold knob depressed.
2. At the same time hold flame failure button depressed.
3. Depress right and left hand piezo igniters until right and left hand pilots ignite.
4. Hold gas control knob and flame failure button depressed for approx. 10 to 15 seconds after igniting both pilot burners, both pilot burners should remain alight.
5. If pilot burners do not ignite, repeat Items 1 to 4 above.

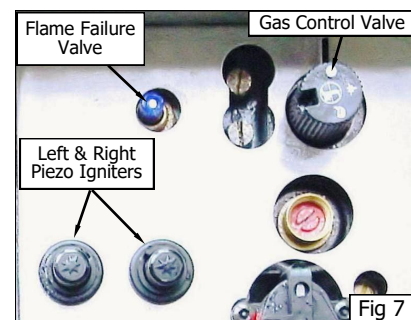

### **FN8226 Fryer (Twin Tank)**

1. Rotate gas control knob to the position marked 'PILOT' and hold depressed.
2. Depress the piezo igniter until pilot ignites.
3. Continue holding the gas control knob depressed for approx. 10 to 15 seconds after igniting pilot burner, pilot burner should remain alight.
4. If pilot burner does not ignite, repeat Items 1 to 3 above.
5. To ignite the second pilot burner, repeat Items 1 to 3 above with the second gas control valve.

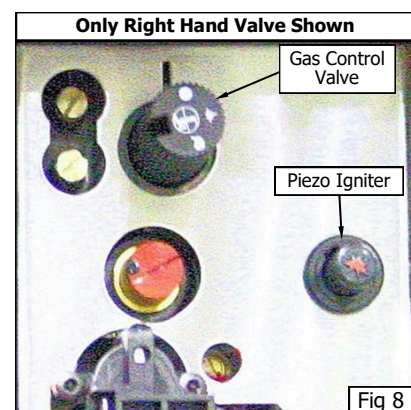

## Operation

### Lighting Main Burners

1. Ensure that pilot burners are alight.
2. Depress and rotate gas control knob to **Full Flame** position.
3. Main burners will ignite automatically off pilot burners.

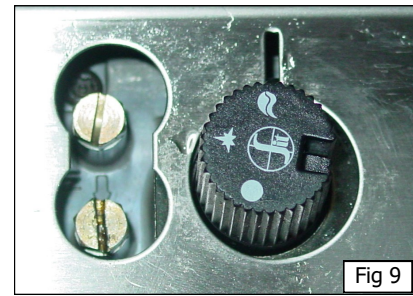

#### NOTE:

- If main burners are turned 'On' immediately after pilot burners are lit, a delay of approximately 30 seconds will occur until the thermopile (which provides power to open the main valve) has heated up from the pilot burners.
- Main burners will not light if frying medium temperature is above thermostat set temperature.
- Turning gas control knob from pilot to main burner position will allow manual cycling of burners 'On' and 'Off' when melting shortening.

### Setting the Operating Temperature

1. Rotate thermostat to the required temperature.
2. Temperature can be set from 145°C to 195°C, although we do not recommend any food to be cooked above 190°C.
3. Main burners will operate automatically to maintain this temperature.

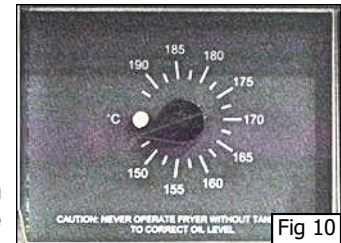

**NOTE:** As a safety precaution all WALDORF 'FAST-FRI' Fryers feature an Over-Heat Control, which will 'Turn Off' the fryer should there be a thermostat failure and the oil temperature reaches over 220°C.

### Turning 'OFF' the Fryer

#### To the 'Pilot' Position

- a. Depress and rotate the gas control valve clockwise to the 'Pilot' position.
- b. The main burners will extinguish and the 'Pilot' will remain alight.

#### To the 'Off' Position

- a. Depress and rotate the gas control valve fully clockwise to the 'Off' position.
- b. The 'Pilot' burners will extinguish.

#### IMPORTANT:

Should any abnormal operation like;

- ignition problems,
- abnormal burner flame,
- burner control problems,
- partial or full loss of burner flame in normal operation,

If any of the above problems are noticed, the appliance requires **IMMEDIATE** service by a qualified service person and should not be used until a service is carried out.



# Cleaning and Maintenance

## General



### Warning

**DO NOT USE FLAMMIBLE SOLVENTS AND CLEANING AIDS ON OR IN CLOSE PROXIMITY TO FRYER WHILST FRYER IS STILL HOT.**



### Caution

**Always turn 'Off' gas supply before cleaning.**

**This appliance is not water proof.**

**Do not use water jet spray to clean interior or exterior of this appliance.**

- To achieve the best results, cleaning must be regular and thorough and all controls and mechanical parts checked and adjusted periodically by a qualified service person. If any small faults occur, have them attended to promptly.
- Don't wait until they cause a complete breakdown. It is recommended that the appliance is serviced every 6 months.
- Clean the fryer regularly. A clean fryer looks better, will last longer and will perform better.

### NOTE:

- **DO NOT use abrasive detergents, sharp scrapers, strong solvents or caustic detergents as they could corrode or damage the fryer.**
- **Ensure that any detergent or cleaning material has been completely removed after each cleaning.**

To keep your fryer clean and operating at peak efficiency, follow the procedures below:-

## Draining and Daily Cleaning

1. At end of each day or at end of each shift, if frying schedule is heavy, frying medium should be drained and filtered into a receptacle.



### Warning

**DO NOT ATTEMPT TO MOVE FRYER WHILST FRYER IS FULL OF OIL.**

**BEFORE ATTEMPTING TO MOVE FRYER, ENSURE THAT ALL THE OIL HAS BEEN DRAINED FROM THE TANK. REFER TO INFORMATION ON PREVIOUS PAGE, ON HOW TO DRAIN THE OIL FROM THE FRYER.**



### Caution

**Never drain the fryer with power or burners turned 'ON'  
Always switch 'OFF' fryer before draining or re-filling tank.**

2. Always filter fryer when cool zone under burners is hot and liquid. A cold fryer heated up won't drain, because frying medium in this zone will remain hard if using solid fat / oils.
3. Screw drain extension pipe onto end of drain valve (see Fig 11) and position a suitable container and filter under drain extension pipe.

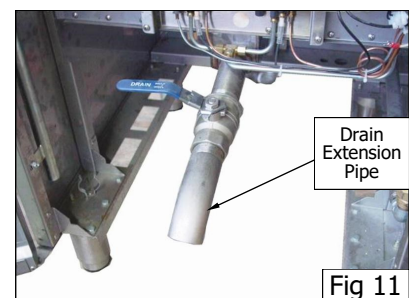

# Cleaning and Maintenance

## Opening the Drain Valve



### Warning

**HOT OIL WILL BURN - DO NOT RUSH THIS JOB.**

- a. Lift locking slide on valve handle (Fig 12) to release valve.
- b. While holding locking slide in withdrawn position, rotate handle anticlockwise (Fig 13) to open valve.
- c. When valve is closed, locking slide will drop down over locking valve to prevent accidental opening of valve as shown in Fig.12.

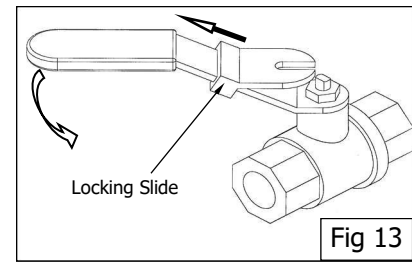
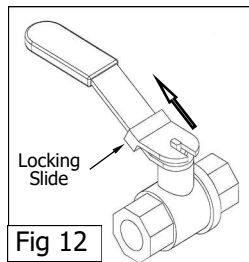

4. Do not empty total fryer contents into one large container, as this will be dangerous and may be difficult, when lifted up, to pour hot oil back into tank.
5. Slip a muslin or other suitable filter bag over the end of the drain valve. Crumbs will be caught in bag but frying medium will strain freely through into receptacle.
6. Open drain valve slowly to minimise splashing, and take care not to overfill container.
7. If necessary, use the drain stick (see Fig 14) to dislodge any blockages in the drain.
8. When tank has been drained, use a ladle or small pan with a handle and dip into hot frying medium from container and pour around sides and bottom of tank to wash out crumbs and particles adhering to tank.
9. Continue to dip and pour until all crumbs are washed down and into filter bag.
10. Open drain valve fully and check for any particles or crumb residue lodged in valve. Clean out valve with a stiff nylon brush. Do not use a wire brush as this can damage the valve seating and will eventually lead to leaking. If obstruction cannot be removed with a brush, use a wooden probe to dislodge obstruction.
11. Wipe all exterior panels with a cloth dampened with detergent and rinse off any residue with clean warm water.
12. Clean Control Panel with a damp cloth lightly moistened with a solution of water and a commercial quality foodservice approved detergent.
13. Once the daily cleaning operation is completed, close drain valve and pour frying medium back into tank.

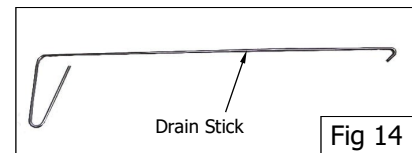

---

## Cleaning and Maintenance

---

### Weekly Cleaning

**NOTE: If fryer usage is very high, we recommend that the weekly cleaning procedure is carried out more frequently.**

1. Proceed to drain and filter the tank as for 'Daily Cleaning'. Do not refill tank with frying medium until it has been cleaned as shown below.
2. Fill fryer with cold water to normal fill level and add a high quality commercial cleaner that has been specifically formulated for fryers. *All purpose cleaners are not recommended.*

**NOTE: Never use a caustic or lye solution, as this will leave a fat destroying film on the tank.**

3. Heat water to approximately 80-90°C.
4. Clean fryer baskets at the same time, by simply immersing them in cleaning solution. Allow fryer to soak for 5-10 minutes or as directed on cleaner instructions. Remove baskets and turn **Off** main burners.
5. Scrub baskets and fryer tank with a stiff nylon bristle brush to remove any remaining deposits. **DO NOT use a wire brush, as this will scratch the tank sides.**
6. Empty fryer and rinse thoroughly with water. Use a 1 part vinegar to 15 parts water solution to rinse tank and neutralise any cleaner residue. If this proves unsuitable for cleaner being used, use a weaker solution of up to 1 part vinegar to 25 parts water.
7. Rinse tank thoroughly with water, drain and dry.
8. Refill tank with new filtered frying medium.

#### **Stainless Steel Surfaces**

- a. With tank(s) drained, cleaned and dried as shown above, clean exterior surfaces of fryer with hot water, a mild detergent solution and a soft cloth.
- b. Dry all components thoroughly with a dry cloth and polish with a soft dry cloth.
- c. To remove any discoloration, use an approved stainless steel cleaner or stainless steel wool. Always rub in direction of the grain.

### Periodic Maintenance

**NOTE: All maintenance operations should only be carried out by a qualified service person.**

To achieve the best results, cleaning must be regular and thorough. All controls and mechanical parts should be checked and adjusted periodically by a qualified service person. If any small faults occur, have them attended to promptly. Don't wait until they cause a complete breakdown. It is recommended that the appliance is serviced every 6 months.

## Fault Finding

### Guide to Cooking Problems with the Fryer

This section provides an easy reference guide to the more common problems that may occur during operation of your equipment. The fault finding guide in this section is intended to help you correct, or at least accurately diagnose problems with your equipment.

Although this section covers the most common problems reported, you may encounter a problem not covered in this section. In such instances, please contact your local authorised service agent who will make every effort to help you identify and resolve the problem. Please note that the service agent will require the following information:-

- **Model Code and Serial Number of appliance, which can be found on the Rating Plate located on the inside of the access door.**

Fault	Possible Cause	Remedy
<b>Frying medium foaming.</b>	Presence of soap or detergent residue from cleaning tank.	Rinse fryer thoroughly three times with clean water. Ensure fryer is perfectly dry before re-filling with frying medium.
	Excessive breakdown of frying medium.	Add fresh frying medium daily to replace contents every 3-5 days.
	Continual frying of food with excess moisture.	Remove excess moisture from foods to be fried.
	Continued overheating of oil.	Check thermostat setting. Turn down heat to around 140°C (Standby) when use is quiet
	Overloading	Maintain 1-8 ratio of food to frying medium.
<b>Gumming.</b>	Heating frying medium too rapidly.	When charging fryer or starting up, melt frying medium gradually.
	Continued overheating of frying medium.	Check oil temperature by using a thermometer or thermocouple.
	Frying oil broken down.	Check amount of fresh frying medium added to fryer to be sure 'turnover' is adequate.
	Using wrong frying medium.	Some frying mediums form gums when used in a deep fryer. e.g safflower oil.
<b>Greasy foods.</b>	Frying at too low a temperature.	Increase temperature and check thermostat setting.
	Inadequate preparation of food.	Be sure foods (especially potatoes) are 'cured' correctly.
	Excessive quantities of breading or batter.	Remove surplus breading or batter.
	Placing food in frying medium direct from freezer.	Allow frozen foods to thaw before frying.
	Surplus moisture in and on surface of food.	Drain and dry foods before frying.
	Frying medium in advanced stages of breakdown.	Discard 'old' frying medium and refill fryer with new medium.
	Use of dripping or other unrefined oil.	Due to low smoking point, cooking in these oils at lower temperatures will result in greater oil absorption by food.
	Using wrong kind of cooking oil.	Always use a completely refined and deodorised cooking oil.

## Fault Finding

Fault	Possible Cause	Remedy
<b>Rapid oil breakdown.</b>	Inadequate frying oil turnover.	Adjust procedures to fry more food in fryer to increase turnover.
	Oil overheating.	Check oil temperature by using a thermometer or thermocouple.
	Contamination.	Filter or strain oil daily.
	Poor cleaning procedures.	Clean fryer each day or at least once a week and rinse thoroughly. Dry fryer before use.
	Presence of copper or brass in the fryer equipment.	Remove all copper or brass fittings from contact with oil.
	Overloading fryer.	Maintain 1-8 ratio of food to frying oil.
	Food excessively moist.	Drain and dry food before frying.
	Overheating oil on 'Standby' mode.	Turn control to <b>Pilot</b> position during idle ('Standby') periods.
<b>Oil smoking.</b>	Insufficient turnover of oil.	Maintain a minimum quantity of oil in fryer for more rapid turnover or increase quantity of food fried in fryer. Replace with fresh oil every 3 to 5 days.
	Continual frying with excess moisture on food.	Drain foods before frying, pat food dry.
	Contamination of oil.	Filter or strain daily to remove contaminants.
	Oil overheating.	Check oil temperature by using a thermometer or thermocouple.
	Rapid breakdown of oil.	Use a stable frying oil.
	Use of unrefined oils.	Dripping smokes at lower temperature than refined and deodorised oils.
<b>Darkening of oil.</b>	Presence of salt on the food.	Salt food after frying and away from fryer.
	Foods dipped in batter high in egg yolk.	Reduce egg content of batter, replace part egg with milk.
	Contamination of oil.	Filter or strain oil daily to remove contaminants.
	Poor cleaning practice.	Clean fryer at least once a week or each day in cases of heavy usage. Ensure fryer is perfectly dry before use.
	Overheating of oil.	Check oil temperature by using a thermometer or thermocouple.
	Insufficient oil turnover.	Top up daily to replace contents of fryer in 3 to 5 days.
	Cooking foods with high sugar levels.	Potatoes are usually high in reduced sugars at the end of a season. When fried, they will darken quickly and discolour the oil.

**NOTE:** Excessive oil usage is an indication of high absorption of oil into food. This is a function of temperature and character of the goods being fried - NOT due to type of oil being used (unless refined oils are being used). Any variation in apparent life of oil is always due to one or more of the causes mentioned above.

## Fault Finding

### Fault Finding the Gas System

Fault	Possible Cause	Remedy
<b>Pilot Burners will not light.</b>	Gas supply is turned <b>Off</b> .	Turn <b>On</b> gas supply.
	Gas bottles empty.	Replace gas bottles.
	Blocked pilot burner.	Call for service.
	Faulty piezo ignition.	Call for service. <b>NOTE: Pilot can be manually lit until repair is carried out.</b>
<b>Pilot Burner lights then goes out when Gas Control Button is released.</b>	Gas valve control button not held <b>In</b> for long enough.	Hold <b>In</b> for at least <b>10 seconds</b> after ignition of the pilot.
	Blocked / weak pilot.	Call for service.
	Low gas pressure.	Call for service.
	Faulty thermocouple.	Call for service.
	Faulty overtemp.	Call for service.
	Faulty gas control valve.	Call for service.
<b>Pilot Burner goes Out during operation.</b>	Low / fluctuating gas pressure.	Call for service.
	Weak pilot.	Call for service.
	Faulty thermocouple.	Call for service.
	Faulty overtemp.	Call for service.
	Faulty gas control valve.	Call for service.
	Overtemp tripped, pilot is turned <b>Off</b> if temperature exceeds 220°C.	Call for service.
<b>Main Burners do not light.</b>	Low gas pressure.	Call for service.
	Blocked pilot.	Call for service.
	Faulty thermostat.	Call for service.
	Faulty thermopile.	Call for service.
	Faulty gas control valve.	Call for service.
<b>Main Burners do not burn correctly.</b> (Burners roar or flash back to Main Injector).	Faulty burner.	Call for service.
	Blockage in flue.	Call for service.

## FN8120G / FNL8120G Fryer - Single Tank

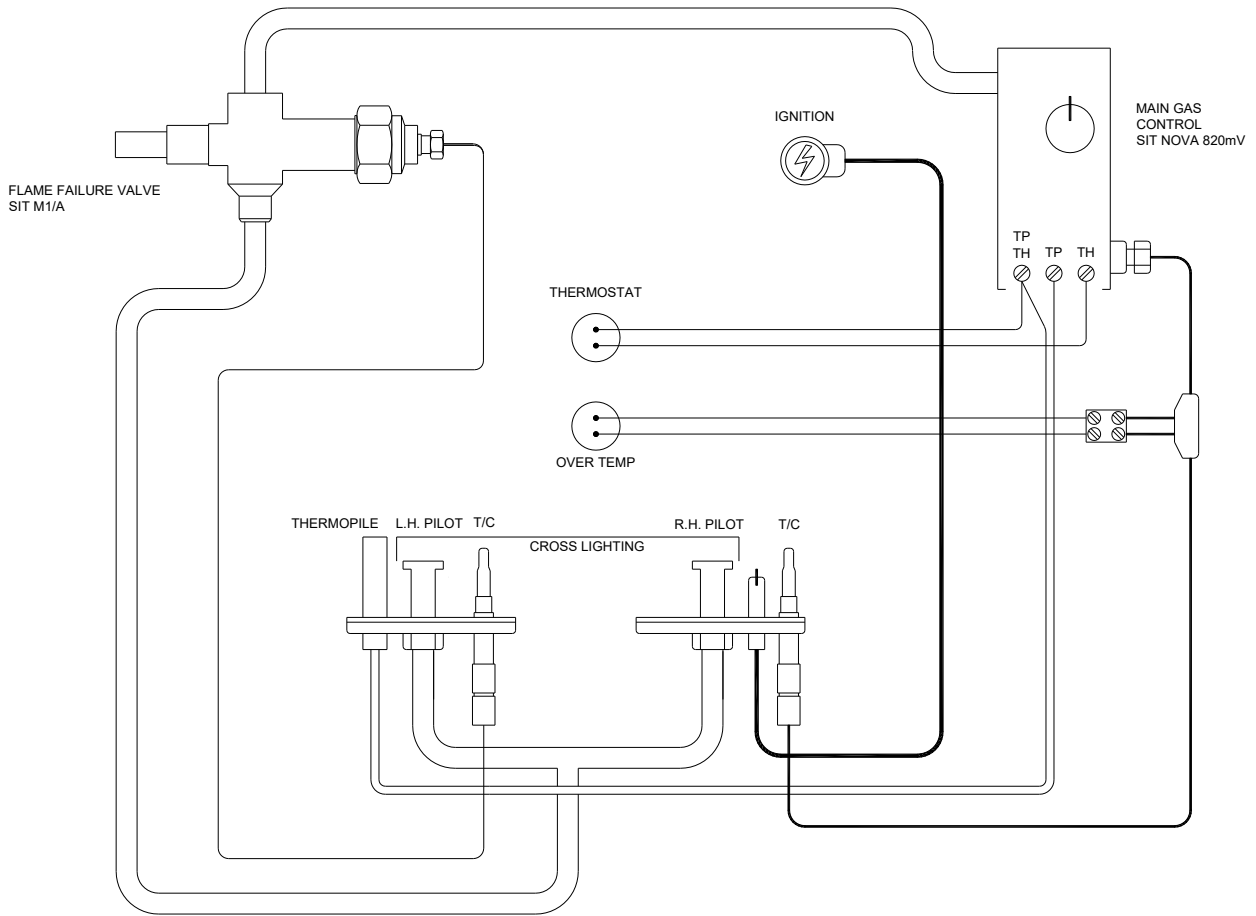

## FN8130G / FNL8130G Fryer - Single Tank

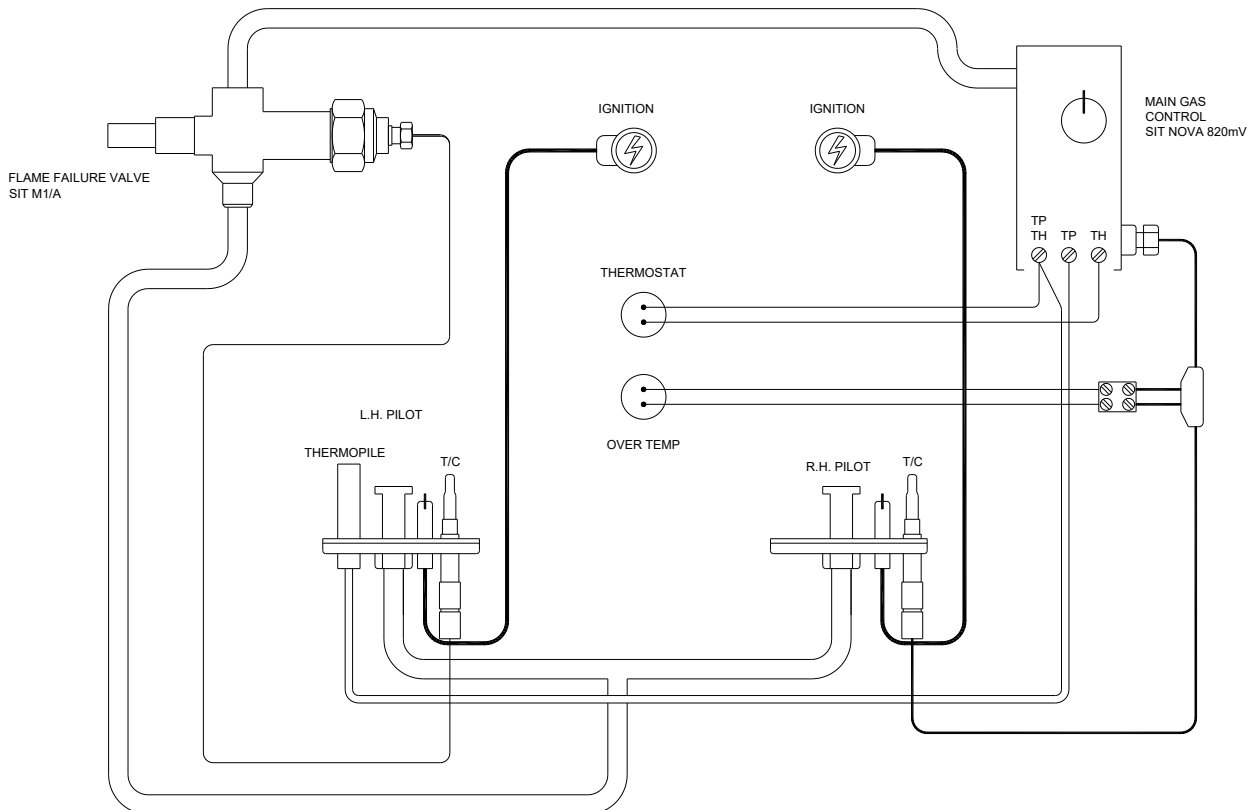

# Wiring Schematics

## FN8226G / FNL8226G Fryer - Double Tank

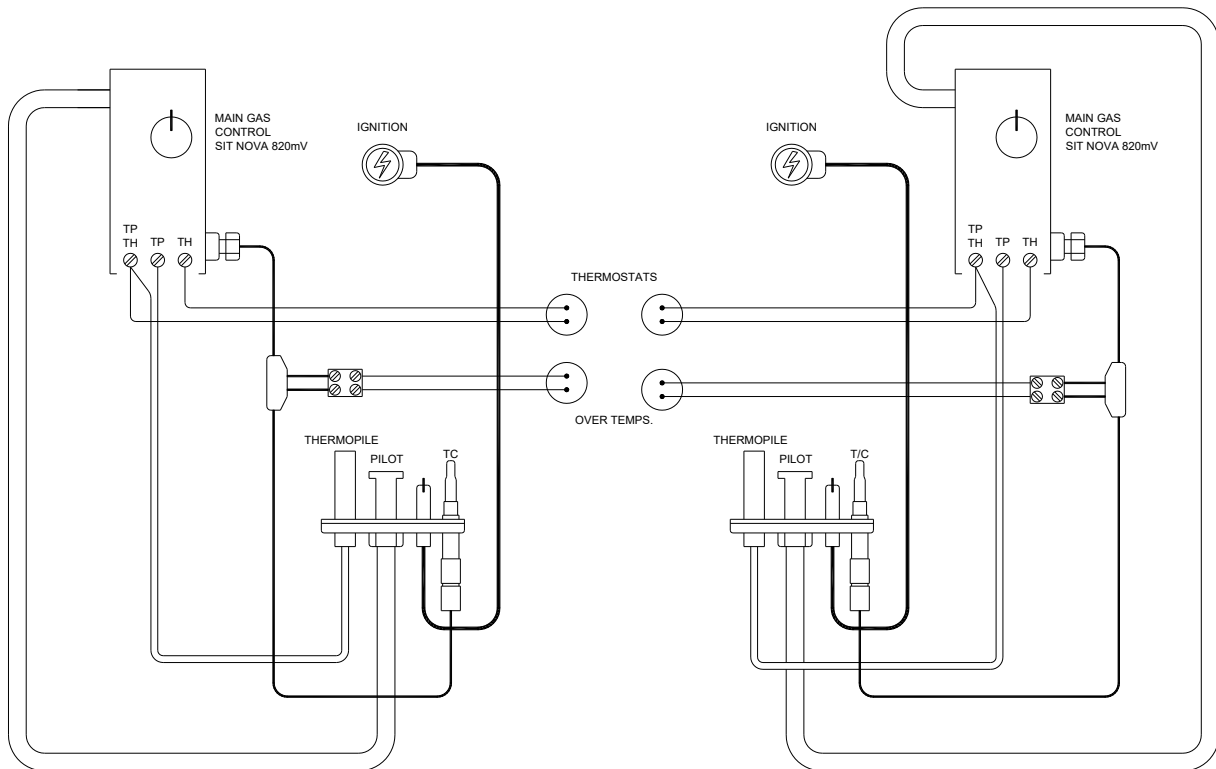



# Gas Supply Connection Location Conversion

## Conversion Procedure



Caution

Ensure Appliance is isolated from the gas supply before commencing servicing.

### NOTE:

- This conversion should only be carried out by qualified persons. All connections must be checked for leaks before re-commissioning appliance.

To convert the unit from Underside to Rear entry gas supply, perform the following steps:

1. Remove rear panel,
2. Unscrew universal joint,
3. Remove supply pipe fastening screws from lower mounting bracket,
4. Reposition supply pipe to align with upper mounting bracket,
5. Reconnect supply pipe at universal joint,
6. Fasten supply pipe to upper mounting bracket,
7. Retighten universal joint,
8. Attach the supplied 3/4" Male-Female galvanised elbow at the end of the supply pipe,
9. Replace rear panel.

To convert the unit from Rear to Underside entry gas supply, perform the above steps in reverse.

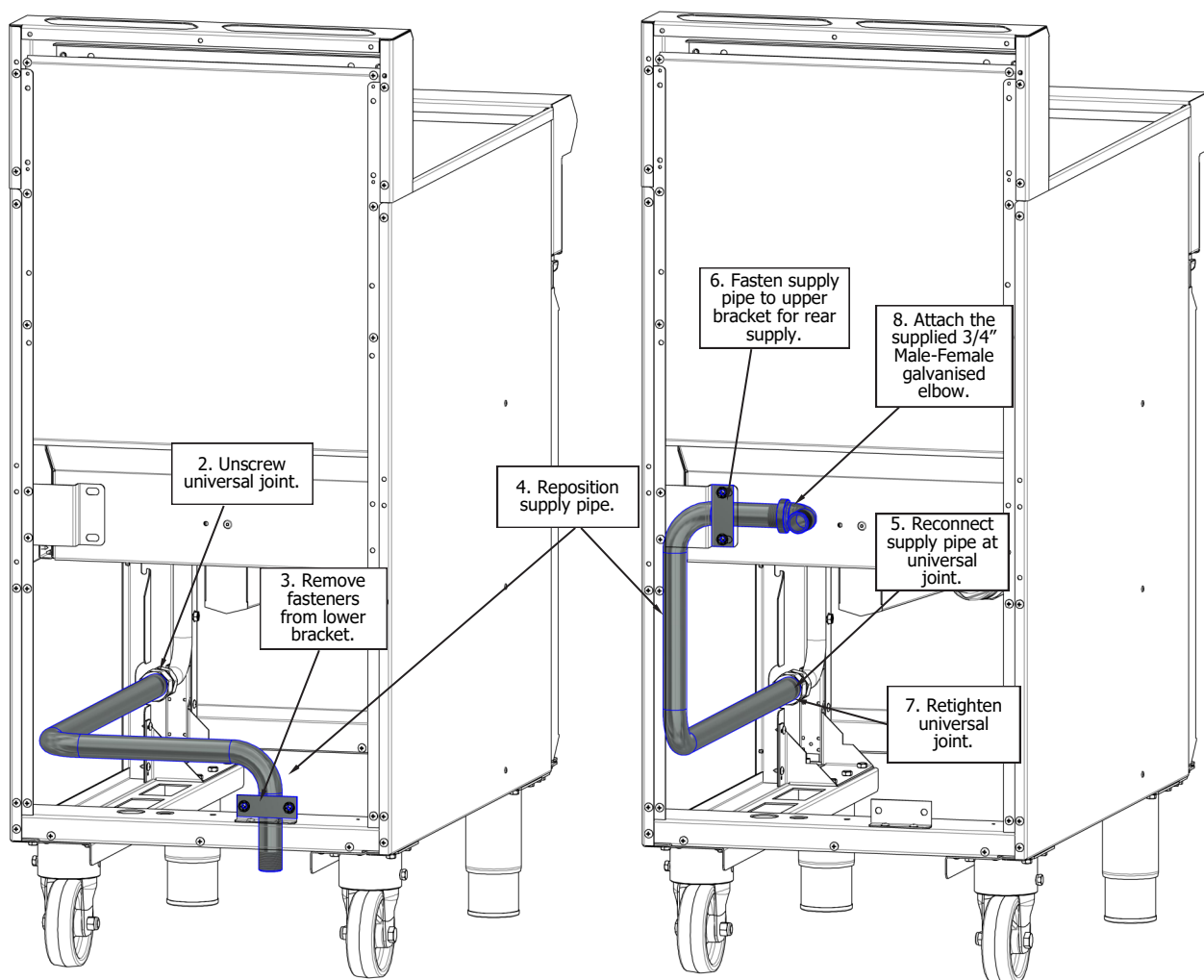

# Gas Conversion and Specifications

## Conversion Procedure



**Caution**

**Ensure Appliance is isolated from the gas supply before commencing servicing.**

### NOTE:

- These conversions should only be carried out by qualified persons. All connections must be checked for leaks before re-commissioning appliance.
- Adjustment of components that have adjustments / settings sealed (e.g. paint sealed) should only be adjusted in accordance with the following instructions and must be re-sealed before re-commissioning this appliance.
- For relevant information and gas specifications refer to table at rear of this section.

### Main Burners

1. Remove main burner injectors and replace with the correct size injectors as shown in **Gas Specifications** table.

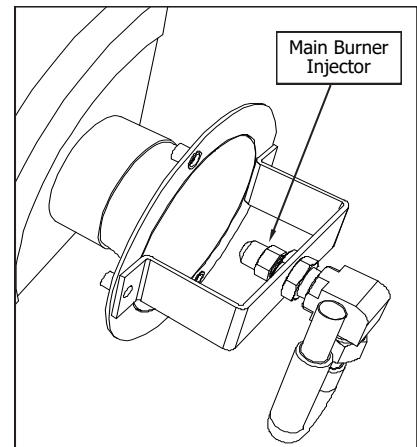

### Pilot Burners

1. Remove the following:-
  - Gas supply tube to pilot burner.

**NOTE: Appliances fitted with piezo igniter electrodes, remove electrode from mounting bracket before unscrewing pilot supply tube.**

2. Remove pilot burner injector and replace with correct size injector as shown in **Gas Specifications Table** at rear of this section.
3. Refit the following:-
  - Gas supply tube to pilot burner.
  - Piezo igniter electrode.

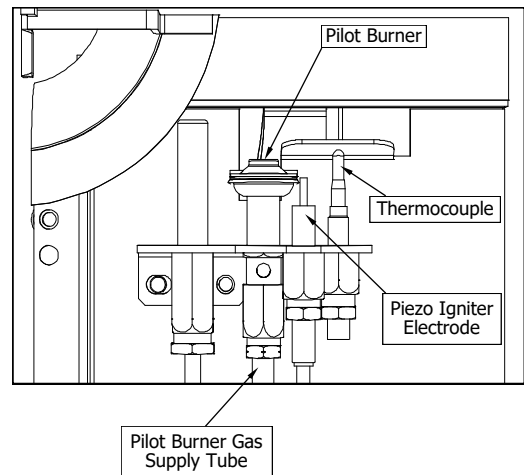

# Gas Conversion and Specifications

## Gas Control Valve

**NOTE:** For Twin Tank Fryers only, the units will be fitted with 2 gas control valves. These valves operate independently of each other. Gas regulator and pilot adjustment will need to be carried out separately for each gas valve.

### Main Burner Supply Pressure Check

- Connect a manometer to the upper test point (**Supply Pressure**) on the gas control valve.

### Main Burner Operating Pressure Adjustment

- Connect a manometer to the lower test point (**Operating Pressure**) on the gas control valve.
- Remove slotted cap to reveal **Operating Pressure Adjusting Screw**.
- Light main burners and turn the operating pressure adjusting screw to obtain correct burner pressure for type of gas being used. Refer to **Gas Specifications Table** at rear of this section.
- Refit slotted cap to screw adjustment point.

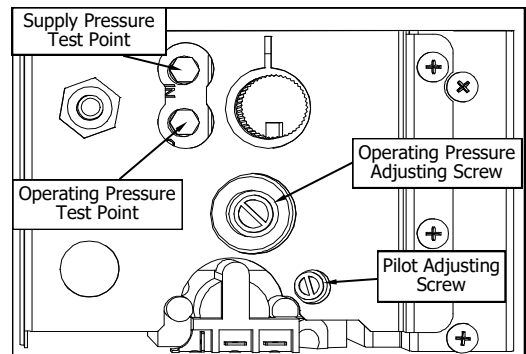

### Pilot Burner Flame Adjustment

- Once main burner operating pressure has been set, adjust pilot burner supply so that the impingement of the pilot flame on the thermocouple and thermopile is correct and main burner pilot flame ignites main burners satisfactorily.
- Adjust pilot flame size by adjusting **Pilot Burner Adjusting Screw**. Pilot burner flame should be approximately 1" long for main burner ignition. Anti-clockwise rotation of adjustment screw will increase size of pilot flame.

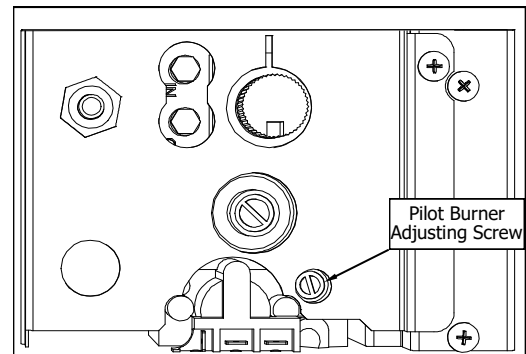

## Gas Type Identification Label

On completion of gas conversion, replace gas type identification label located at:-

- Rear of appliance, above gas connection.
- Beside rating plate.

## Commissioning

Before leaving the converted installation;

- Check all gas connections for leakages using soapy water or other gas detecting equipment.
- Carry out a **Commissioning** check of the appliance as shown in Installation Section of this manual.



### Warning

**DO NOT USE A NAKED FLAME TO CHECK FOR GAS LEAKAGES.**

- Ensure that any adjustments done to components that have adjustments / settings paint sealed, these components are to be re-sealed.

**NOTE:** If for some reason it is not possible to get the appliance to operate correctly, shut 'Off' gas supply and contact supplier of this appliance.

# Gas Conversion and Specifications

## Gas Specifications

### - Australia

	<b>Natural Gas</b>	<b>LP Gas (Propane)</b>
<b>Main Burner Injectors</b>	Ø 3.10mm	Ø 1.90mm
<b>Pilot Burner Injectors</b>	0.62	0.35
<b>Pilot Screw Adjustment</b>	Full Out (CCW)	1½ turns out (CCW)
<b>Burner Operating Pressure (*)</b>	0.98 kPa	2.50 kPa
<b>Supply Pressure</b>	1.13 - 2.0 kPa	2.75 - 3.0 kPa

### - New Zealand:

	<b>Natural Gas</b>	<b>LP Gas</b>
<b>Main Burner Injectors</b>	Ø 3.10mm	Ø 1.80mm
<b>Pilot Burner Injectors</b>	0.62	0.35
<b>Pilot Screw Adjustment</b>	Full Out (CCW)	1½ turns out (CCW)
<b>Burner Operating Pressure (*)</b>	0.98 kPa	2.50 kPa
<b>Supply Pressure</b>	1.13 - 2.0 kPa	2.75 - 3.0 kPa

### - United Kingdom & EU (CE):

Category: **II<sub>2H3P</sub>(20. 37), II<sub>2H3B/P</sub>.(20, 28-30).**

Flue Type: **A<sub>1</sub>.**

	<b>Natural Gas (G20)</b>	<b>Propane (G31)</b>	<b>LP Gas (G30-G31)</b>
<b>Main Burner Injectors</b>	Ø 3.10mm	Ø 1.90mm	Ø 1.80mm
<b>Pilot Burner Injectors</b>	0.45	0.30	0.30
<b>Pilot Screw Adjustment</b>	Full Out (CCW)	1½ turns out (CCW)	1½ turns out (CCW)
<b>Burner Operating Pressure (*)</b>	0.98 kPa	2.50 kPa	2.50 kPa
<b>Supply Pressure</b>	20 mbar	37 mbar	28 - 30 mbar

### NOTE:

- \* Measure burner operating pressure at Operating Pressure Test Point (Lower - Out) on gas control valve , this is to be carried out with both burners operating at the 'High Flame' setting. Refer to information in this section for further details.

## Gas Conversion and Specifications

---

### - All Other Markets

	Natural Gas	Town Gas (**)
<b>Main Burner Injectors</b>	Ø 3.10mm	Ø 6.30mm
<b>Pilot Burner Injectors</b>	0.62	0.75
<b>Pilot Screw Adjustment</b>	Full Out (CCW)	Full Out (CCW)
<b>Burner Operating Pressure (*)</b>	0.98 kPa	0.50 kPa
<b>Supply Pressure</b>	1.13 - 2.0 kPa	0.75 - 1.50 kPa

	LP Gas	Butane
<b>Main Burner Injectors</b>	Ø 1.80mm	Ø 1.70mm
<b>Pilot Burner Injectors</b>	0.35	
<b>Pilot Screw Adjustment</b>	1½ turns out (CCW)	
<b>Burner Operating Pressure (*)</b>	2.50 kPa	
<b>Supply Pressure</b>	2.75 - 3.00 kPa	

**NOTE:**

- (\*) Measure burner operating pressure at Operating Pressure Test Point (Lower - Out) on gas control valve, with both burners operating at 'High Flame' setting.
- (\*\*) TOWN GAS Option is only available with specific ex-factory built Town Gas Models, which can also be converted to any other gas. Standard models can only be converted between Nat. Gas, LP Gas and Butane, but not Town Gas.
- Refer to 'Gas Conversion and Specifications' in this manual for further details.

## Replacement Parts List

### Replacement Parts List

#### IMPORTANT:

Only genuine authorized replacement parts should be used for servicing and repair of this appliance. Instructions supplied with these parts should be followed when replacing components.

For further information and servicing instructions, contact your nearest authorized service branch (contact details are as shown on reverse of front cover of this manual).

When ordering spare parts, please quote part number and description as listed below. If part required is not listed below, request part by description and quote model number and serial number which is shown on rating plate.

#### Controls

018094	Interrupted Thermocouple - Main Gas Valve.		
227865	Thermocouple - Flame Failure Valve	(Single Tank Models Only).	
019237	Flame Failure Valve.	(Single Tank Models Only).	
018089K	Gas Control Kit.		
018093	Thermopile.		
032190	Main Burner Injector	(LPG (Propane))	ø 1.90mm.
032180	Main Burner Injector	(LPG)	Ø 1.80mm.
032170	Main Burner Injector	(LPG (Butane))	ø 1.70mm.
032310	Main Burner Injector	(Nat Gas) -	ø 3.10mm.
032630	Main Burner Injector	(Town Gas) -	ø 6.30mm.
018090K	Pilot Burner (includes electrode)	(Not UK).	
025630K	Pilot Burner (includes electrode)	(UK Only).	
018971	Pilot Injector	(LPG UK) -	0.30.
018972	Pilot Injector	(Nat Gas UK) -	0.45.
018092	Pilot Injector	(LPG / Butane)	0.35.
018091	Pilot Injector	(Nat Gas)	0.62.
026393	Pilot Injector	(Town Gas)	0.75.
018095	Piezo H.T. Lead.		
227508	Piezo Ignitor.		
022575	Burner Kit.		
018145	Thermostat Knob.		
018021K	Thermostat.		
242757K	Overtemp Thermostat Kit 2019.		

#### General

018019	Basket.		
227856	Door Magnet.		
236795	Drain Valve.		
018147	Drain Extension.		
018176	Drain Stick.		
228576	Basket Tray	(FN8120G).	
228577	Basket Tray	(FN8226G).	
228578	Basket Tray	(FN8130G).	
228761	Lid c/w Handle	(FN8120G / FN8226G).	
228762	Lid c/w Handle	(FN8130G).	
229674	Rear Roller Assy.		
227850	Leg Adjustable 150mm	(Flush Stud).	

# Replacement Parts List

## Accessories (Optional)

228793      450mm (Fryer) Plinth Kit.  
 228794      600mm (Fryer) Plinth Kit.

Splashguard

Fryer  
 To Cooktop Open Burners.  
 To Target Top.  
 To Cooktop Electric.

NOTE: Splashguard accessory fits to side of Fryer.

LH (Part No. 228898).  
 RH (Part No. 228899).

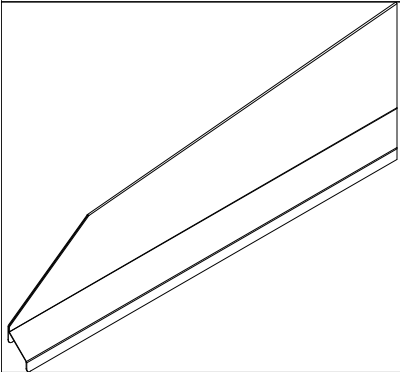

Drain Adaptor  
 (Part No. 024705).

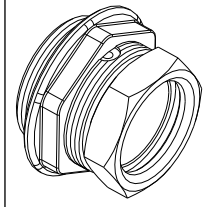

Drain Extension Kit  
 (Part No. 024710).

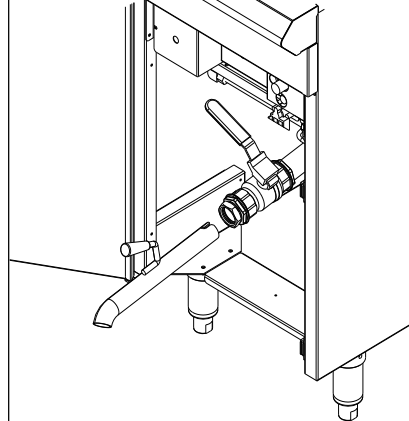

Splashguard

Fryer  
 To Cooktop Griddle.  
 To Chargrill.  
 To Griddle.  
 To Griddle Toaster.  
 To Cooktop Electric Griddle.

NOTE: Splashguard accessory locates into side splashguard on connected appliance.

LH (Part No. 228894).  
 RH (Part No. 228895).

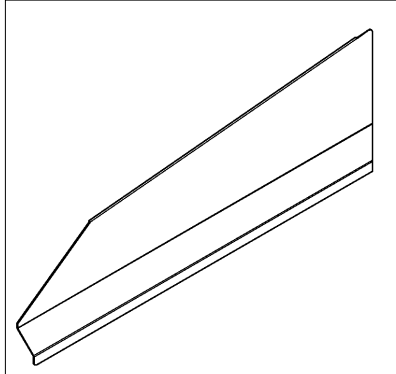

Joining Strip  
 Fryer to Fryer.  
 (Part No. 228600).

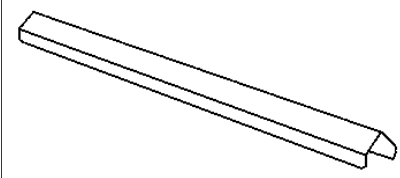

Tank Divider (Part No. 243638).

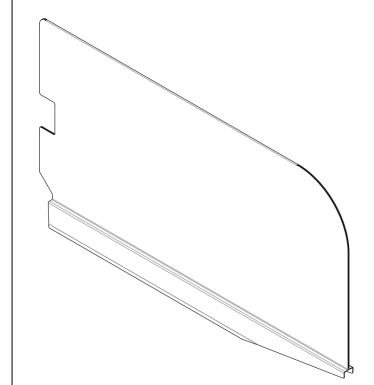

## Gas Conversion Kits

Model	Gas Type to Convert to:						
	Nat. Gas (AU/NZ/Export)	Nat. Gas (UK)	LP Gas (Propane) (AU)	LP Gas (NZ, Export)	LP Gas (Propane) (UK)	Butane	Town Gas
FN8120G FN8226G FN8130G	231963	231967	231962	244510	231966	231964	N/A (*)

**NOTE:** (\*) Town Gas Option is only available with specific ex-factory built Town Gas models, which can also be converted to any other gas. Standard models can only be converted between Nat. Gas, LP Gas and Butane, but not Town Gas.





---