

# **Waldorf**<sup>®</sup> 800 SERIES

Installation and Operation Manual

## Electric Range

RN8610SE RNL8610SE RNB8610SE RNLB8610SE  
RN8610SEC RNL8610SEC RNB8610SEC RNLB8610SEC



_____
Date Purchased
_____
Serial Number
_____
Dealer
_____
_____
Service Provider
_____
_____



---

## MANUFACTURED BY

**Moffat Limited**  
Rolleston 7675  
New Zealand

## INTERNATIONAL CONTACTS

### AUSTRALIA

**Moffat Pty Limited**

**Web:** [www.moffat.com.au](http://www.moffat.com.au)  
**E.Mail:** [vsales@moffat.com.au](mailto:vsales@moffat.com.au)  
**Main Office:** (tel) +61 (03) 9518 3888  
(fax) +61 (03) 9518 3833  
**Service:** (tel): 1800 622 216  
**Spares:** (tel): 1800 337 963  
**Customer Service:** (tel): 1800 335 315  
(fax): 1800 350 281

### CANADA

**Serve Canada**

**Web:** [www.servecanada.com](http://www.servecanada.com)  
**E.Mail:** [info@servecanada.com](mailto:info@servecanada.com)  
**Sales:** (tel): 800 551 8795 (Toll Free)  
**Service:** (tel): 800 263 1455 (Toll Free)

### NEW ZEALAND

**Moffat Limited**

**Web:** [www.moffat.co.nz](http://www.moffat.co.nz)  
**E.Mail:** [sales@moffat.co.nz](mailto:sales@moffat.co.nz)  
**Main Office:** (tel): 0800 663328

### UNITED KINGDOM

**Blue Seal**

**Web:** [www.blue-seal.co.uk](http://www.blue-seal.co.uk)  
**E.Mail:** [sales@blue-seal.co.uk](mailto:sales@blue-seal.co.uk)  
**Sales:** (tel): +44 121 327 5575  
(fax): +44 121 327 9711  
**Spares:** (tel): +44 121 322 6640  
(fax): +44 121 327 9201  
**Service:** (tel): +44 121 322 6644  
(fax): +44 121 327 6257

### UNITED STATES

**Moffat**

**Web:** [www.moffat.com](http://www.moffat.com)  
**Sales:** (tel): 1-800 551 8795 (Toll Free)  
(tel): 336 661 1556  
(fax): 336 661 9546  
**Service:** (tel): 866 673 7937 (Toll Free)

### REST OF WORLD

**Moffat Limited**

**Web:** [www.moffat.co.nz](http://www.moffat.co.nz)  
**E.Mail:** [export@moffat.co.nz](mailto:export@moffat.co.nz)

---

The reproduction or copying of any part of this manual by any means whatsoever is strictly forbidden unless authorized previously in writing by the manufacturer.

In line with policy to continually develop and improve its products, Moffat Ltd. reserves the right to change the specifications and design without prior notice.

© Copyright Moffat Ltd. August 2024.

---

## Waldorf Electric Ranges Convection / Static Ovens - 900 mm

**RN(L)(B)8610SE    Electric Range Static Oven.**

**RN(L)(B)8610SEC    Electric Range Convection Oven.**

<b>Introduction .....</b>	<b>2</b>
<b>Specifications .....</b>	<b>3</b>
Model Numbers Covered in this Specification	
General	
Electrical Supply Requirements	
Electrical Connection	
Dimensions	
<b>Installation .....</b>	<b>5</b>
Installation Requirements	
Unpacking	
Location	
Clearances	
Assembly	
Fitting Rear Rollers	
Electrical Connection	
Commissioning	
<b>Operation .....</b>	<b>8</b>
Operation Guide	
Description of Controls	
Hotplate Elements	
Oven	
<b>Cleaning and Maintenance .....</b>	<b>10</b>
General	
After Each Use	
Daily Cleaning	
Weekly Cleaning	
Periodic Maintenance	
<b>Fault Finding .....</b>	<b>12</b>
<b>Wiring Diagrams .....</b>	<b>13</b>
<b>Circuit Schematics .....</b>	<b>16</b>
<b>Replacement Parts .....</b>	<b>17</b>

---

## Introduction

---

We are confident that you will be delighted with your WALDORF ELECTRIC RANGE and it will become a most valued appliance in your commercial kitchen.

To ensure you receive the utmost benefit from your new Waldorf ELECTRIC RANGE, there are two important things you can do.

### **Firstly:**

Please read the instruction book carefully and follow the directions given. The time taken will be well spent.

### **Secondly:**

If you are unsure of any aspect of the installation, instructions or performance of your appliance, contact your WALDORF dealer promptly. In many cases a phone call could answer your question.

### **CE Only:**

These instructions are only valid if the country code appears on the appliance. If the code does not appear on the appliance, refer to the supplier of this appliance to obtain the technical instructions for adapting the appliance to the conditions for use in that country.

### **WARNING:**

**IMPROPER INSTALLATION, ADJUSTMENT, ALTERATION, SERVICE OR MAINTENANCE CAN CAUSE PROPERTY DAMAGE, INJURY OR DEATH. READ THE INSTALLATION, OPERATING AND MAINTENANCE INSTRUCTIONS THOROUGHLY BEFORE INSTALLING OR SERVICING THIS APPLIANCE.**

### **WARNING:**

**GREAT CARE MUST BE TAKEN BY THE OPERATOR TO USE THE EQUIPMENT SAFELY TO GUARD IT AGAINST RISK OF FIRE.**

- **THE APPLIANCE MUST NOT BE LEFT ON UNATTENDED.**
- **IT IS RECOMMENDED THAT A REGULAR INSPECTION IS MADE BY A COMPETENT SERVICEMAN TO ENSURE CORRECT AND SAFE OPERATION OF YOUR APPLIANCE IS MAINTAINED.**
- **DO NOT STORE OR USE GASOLINE OR OTHER FLAMMABLE VAPOURS OR LIQUIDS IN THE VICINITY OF THIS OR ANY OTHER APPLIANCE.**
- **DO NOT SPRAY AEROSOLS IN THE VICINITY OF THIS APPLIANCE WHILE IT IS IN OPERATION.**

### **CAUTION:**

**This appliance is;**

- **For professional use and is to be used by qualified persons only.**
- **Only authorised service persons are to carry out installation, servicing and gas conversion operations.**
- **Components having adjustments protected (e.g. paint sealed) by the manufacturer should not be adjusted by the user / operator.**
- **DO NOT operate the appliance without the legs supplied fitted.**

## Model Numbers Covered in this Specification

Model Number	Model Type	Total Power Input	Net Weight
RN[1]8610SE	Electric Range Static Oven with 6 Hotplate Elements.	22.1 kW	182 kg
RN[1]8610SEC	Electric Range Convection Oven with 6 Hotplate Elements	22.4 kW	182 kg

**NOTE:**

**[1]: Model Options:**

- - Standard.
- L - Low Back.
- B - Bold Front.
- LB - Low Back and Bold Front.

## General

A commercial heavy duty, 900 mm wide Electric Range designed for modular kitchens and is constructed in an easy clean stainless steel external finish.

The range is fitted with either a 900 mm 6.5kW electric static oven or convection oven.

## Electrical Supply Requirements

Model	Power Supply			Total Power Input	Amps @ 400 - 415 Vac			Motor
	Voltage	Type	Frequency		L1	L2	L3	
RN8610SE	400-415 Vac	3 P+N+E	50 / 60 Hz	22.1 kW	29.4	30.4	30.4	----
RN8610SEC	400-415 Vac	3 P+N+E	50 / 60 Hz	22.4 kW	31.3	31.1	31.1	100 W

## Electrical Connection

**WARNING:**

**THIS APPLIANCE MUST BE EARTHED. IF THE SUPPLY CORD IS DAMAGED, IT MUST BE REPLACED BY A SUITABLY QUALIFIED PERSON IN ORDER TO AVOID A HAZARD.**

Electrical supply connection point is located at the rear of the appliance, approximately 130mm from the right hand side, 30mm from the rear and 675mm from the floor.

When connecting this electric appliance to the mains supply, ensure that the following is carried out:

- An isolating switch is fitted within 2m of the appliance, but not on the appliance and in such a position that the user does not have to reach across the cooking surface.
- Supply cord shall be oil-resistant, sheathed flexible cable and not lighter than ordinary polychloroprene or other equivalent synthetic elastomer sheathed cord (as per AS / NZS 3191 part 2.10.11. or IEC 60245-IEC-57) e.g. HO5 RN-F Type.
- The branch supply line shall be individually overload protected to the correct current rating and the supply chord shall be protected against any mechanical or thermal damage.
- A cable gland is fitted to the wiring entry hole at the rear of the appliance.
- Supply cable wires should be boot laced and all terminal connections must be tight to avoid potential self-overheating.

Refer to the appropriate wiring standards for the size of cable that is to be supplied to an appliance for the current drawn on that line.

# Specifications

## Dimensions

RN(L)8610SE / SEC

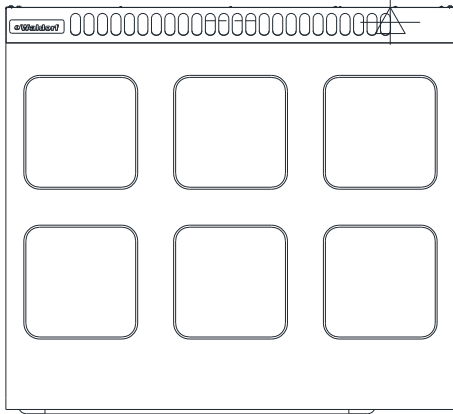
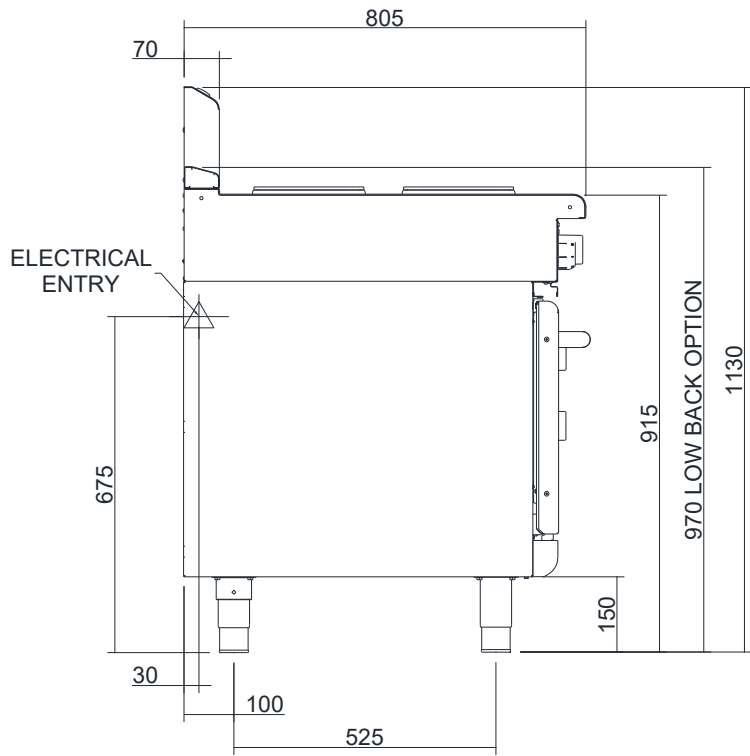
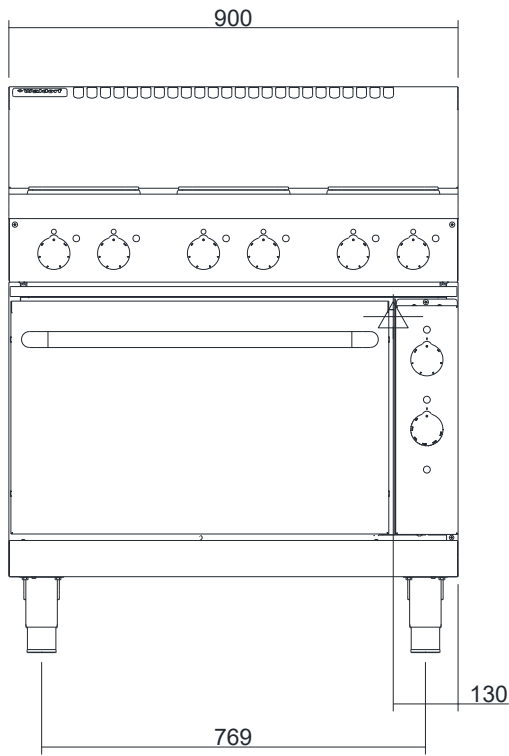

## Installation Requirements

### NOTE:

- It is most important that this Electric Range Static / Convection Oven is installed correctly and that operation is correct before use. Installation shall comply with local electrical and health and safety requirements.
- This appliance shall be installed with sufficient ventilation to prevent the occurrence of unacceptable concentrations of health harmful substances in the room, the appliance is installed in.

Waldorf Electric Range Static / Convection Oven are designed to provide years of satisfactory service, and correct installation is essential to achieve the best performance, efficiency and trouble-free operation. This appliance must be installed in accordance with National Installation Codes and in addition, in accordance with relevant National / Local codes covering electrical and fire safety.

**Australia / New Zealand:** - AS / NZS3000 - Wiring Rules.  
**United Kingdom:** - BS 7671 - Requirements for Electrical Installations.

**Installations must be carried out by authorised persons only. Failure to install equipment to the relevant codes and manufacturer's specifications shown in this section will void the warranty.**

## Unpacking

1. Remove all packaging and transit protection from the appliance including all protective plastic coating from the exterior stainless steel panels.
2. Check equipment and parts for damage. Report any damage immediately to the carrier and distributor.
3. Report any deficiencies to the distributor who supplied the appliance.
4. Check that the available electrical supply is correct to that shown on the lower R/H side of the front sill panel.

## Location

1. Installation must include adequate clearance and ventilation.
2. Position the appliance in its approximate working position.
3. The legs must always be fitted. Ensure that the legs are securely attached.

## Clearances

	Combustible Surface	Non Combustible Surface
Left / Right hand side	150 mm	0 mm
Rear	50 mm	0 mm

**NOTE:** Only non-combustible materials can be used in close proximity to this appliance.

# Installation

## Assembly

### **CAUTION:**

- This appliance is for professional use and is to be used by qualified persons only.
- Only qualified service persons are to carry out installation and servicing of this appliance.

### **All Models**

All models are delivered completely assembled. Ensure that the legs are securely attached.

### **NOTE:**

- This appliance is fitted with adjustable feet to enable it to be positioned securely and level on uneven floors. This should be carried out on completion of the electrical connection. Refer to the 'Electrical Connection' section.
- This appliance can also be fitted with rear rollers to enable the appliance to be easily moved for positioning and cleaning purposes. If desired, these rollers are supplied in the packaging, with the appliance. See below for fitting instructions.

### **Optional Accessories (Refer to Replacement Parts List)**

- Plinth Kit. For installation details, refer to the instructions supplied with each kit.

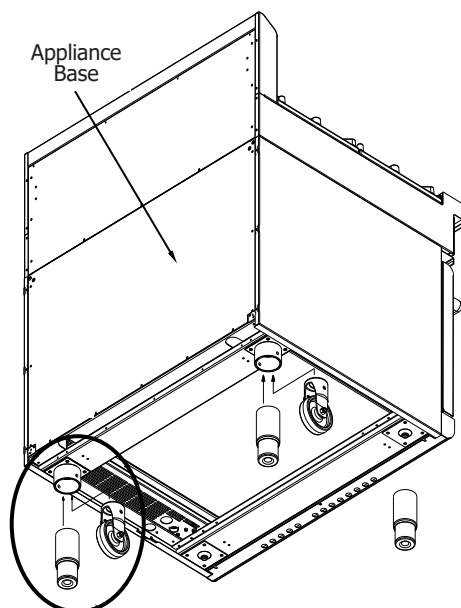
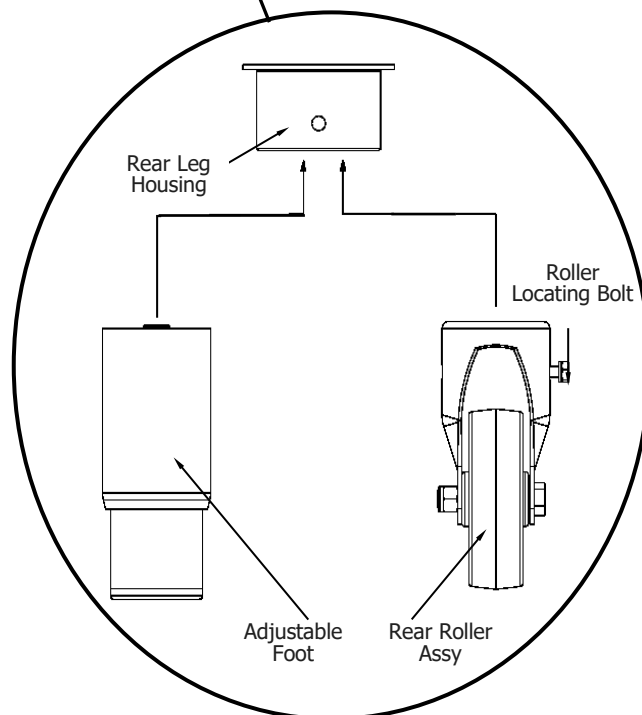

Fig 1

### **Fitting Rear Rollers.**

1. Raise the appliance from the floor by approx. 75mm using suitable lifting equipment (i.e. Palletiser / Forklift) to allow the rear adjustable feet to be removed.
2. Unscrew and remove both the rear adjustable feet from the rear leg housings.
3. Fit the rear roller to the rear leg housing and align the screw hole in the side of the rear leg housing with the threaded hole in the rear roller.
4. Secure the rear roller to the leg support with the bolt supplied and tighten the bolt using a 10mm A/F spanner.
5. Fit the second roller and tighten.
6. Lower the appliance back to the floor and adjust the front adjustable feet to level the appliance.





## Electrical Connection

### **WARNING:**

**THIS APPLIANCE MUST BE EARTHED. IF THE SUPPLY CORD IS DAMAGED, IT MUST BE REPLACED BY A SUITABLY QUALIFIED PERSON IN ORDER TO AVOID A HAZARD.**

**NOTE: ALL ELECTRICAL CONNECTIONS MUST ONLY BE CARRIED OUT BY AN AUTHORISED PERSON.**

Each appliance should be connected to an adequately protected power supply and isolation switch mounted adjacent to, but not behind the appliance. This switch must be clearly marked and readily accessible in case of fire.

1. Check that the electricity supply is correct as shown on the Rating Plate attached to the lower front R/H side of the sill.
2. The supply terminal connections are located at the rear of the appliance. Refer to 'Electrical Connections' in the 'Specifications' section of the manual.
3. Bring the supply cable up through the compression type gland provided on the rear electrical connection housing.
4. Connect the mains supply to L1, L2 and L3 connections for 3 phases. Refer to the 'Electrical Supply Requirements' section for connection details.
5. Connect neutral and earth conductors to neutral and earth connections respectively.
6. For all connections ensure that the conductors are secure and appropriately terminated.
7. Tighten the cable gland to secure against tension on the cable.

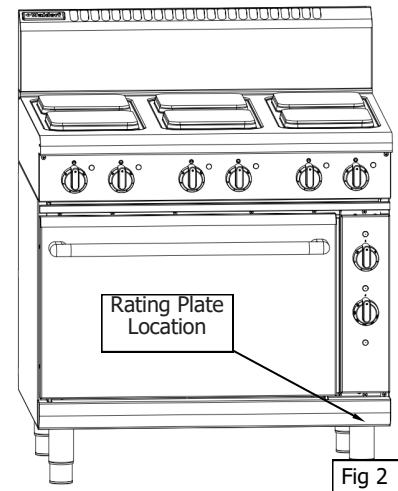

**NOTE:**

- **This appliance must be earthed.**
  - **Fixed wiring installations must incorporate an all-pole disconnection switch.**
8. Correctly locate the appliance into its final operating position and, using a spirit level, adjust the legs so that the appliance is level and at the correct height.
  9. Connect the power supply to the appliance.
  10. Check that the electrical supply is as shown in the 'Specifications' section.

## Commissioning

1. Before leaving the new installation;
  - a. Check the following functions in accordance with the operating instructions specified in the 'Operation' section of this manual.
    - Check the current draw and loading for the equipment. Refer to the 'Specifications' section for correct electrical requirements.
    - Check that all the connections are correct and that all cover panels have been re-fitted.
    - Check that the appliance functions in accordance with the operating instructions.
    - Ensure that this instruction manual is left with the appliance.
    - Ensure that all the relevant details and contacts have been added to the front of this manual.
  - b. Ensure that the operator has been instructed in the areas of correct operation and shutdown procedure for the appliance.
2. This manual must be kept by the owner for future reference and as a record of **Date of Purchase, Date of Installation** and **Serial Number of Unit** are to be recorded and kept with this manual. **(These details can be found on the Rating Plate).** (Refer to the 'Electrical Connection' section for rating plate location).

# Operation

## Operation Guide

### **CAUTION:**

- **This appliance is for professional use and is to be used by qualified persons only.**
- **Only qualified service persons are to carry out installation and servicing of this appliance.**

1. Waldorf Electric Range Static / Convection Ovens have been designed to provide simplicity of operation.
2. Despite the Cooktop's commercial heavy duty robust construction, incorrect operation practices can reduce the life of the appliance and produce a poor quality product. To use this appliance correctly please read the following sections carefully.

- **Cast Iron Hotplate Elements.**
- **Oven.**

## Description of Controls

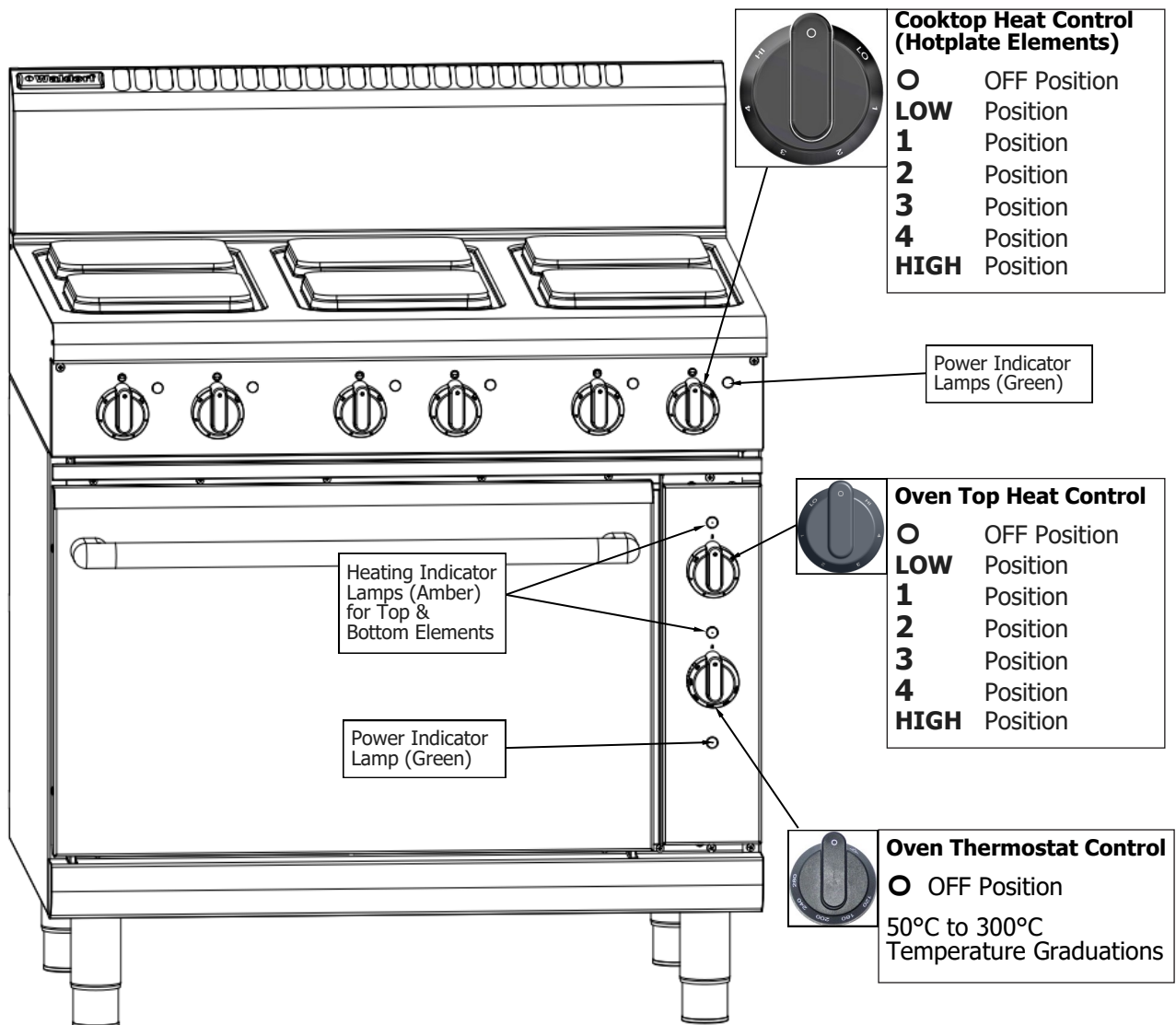

Fig 3

### Cast Iron Hotplate Elements

The controls for the cast iron hotplate elements may be set at any position between high and low to provide the desired level of heating. An individual green neon for each element, will glow when the element is powered on, i.e. heat control is set to an "ON" position.

Start cooking at the highest setting, and change to a lower setting when the desired temperature is reached.

For maximum speed and economy, it is most important that cooking pots/pans should cover the hotplate completely and have perfectly flat bases. Any part of the hotplate which is not making effective contact with the base of the pot/pan decreases the life and efficiency of the hotplate.

Pots/pans which are significantly larger than the hotplate may also reduce hotplate life and efficiency.

### Oven

The oven is fitted with top and bottom elements. The thermostat maintains the overall oven temperature. The top element is further controlled by the oven top heat control.

**NOTE: The Thermostat on the oven provides overall control of the temperature within the oven by controlling both elements, whereas the Oven Top Heat Control provides a means of balancing the distribution of heat between the top and bottom of the oven.**

Convection Ovens (RN8610SEC) are fitted with a circulation fan.

Place oven racks in the desired position.

**! IMPORTANT** DO NOT USE aluminium foil or trays directly on the cast iron sole plate(s). NEVER block or cover the openings on each side of the sole plate(s).

#### Preheat:

Preheat the oven by selecting the desired temperature, and turning the oven top heat control (Refer to Fig 3 on the previous page) to a maximum of 2. When the desired temperature is reached, the amber neon will go out.

#### Cooking:

When the desired temperature has been reached, load the oven with product and set the oven top heat control to the desired setting.

**NOTE: When the oven top heat control is set to a high setting, proportionally more heat is produced at the top of the oven. (This can be used for browning, etc, during the cooking operation). With the oven top heat control set on a low setting, less heat is produced from the top oven elements. (This mode is used for general baking purposes to prevent cakes, etc, from getting too brown and crisp on the top, but allow the cake to cook through).**

To obtain more top heat during cooking, turn the oven top heat control to a higher position. (The higher the setting, the more top heat).

#### Turning 'OFF' the Oven:

- Turn the oven top heat control to the 'O' off position. The top heating will be turned 'OFF' and the upper heating indicator lamp (Amber) will extinguish.
- Turn the thermostat control knob to the 'O' off position and the lower heating indicator lamp (Amber) will extinguish. The oven is now turned 'OFF'.

#### NOTE:

- If for some reason it is not possible to get the unit to operate correctly, turn off the electrical power supply and contact a qualified service person. The supplier of this unit will be able to recommend a suitable person.
- Make sure that the electrical supply is turned "Off" before any service or maintenance work is carried out.

## Cleaning and Maintenance

---

### General

**CAUTION:**

**Always turn off the electrical power supply at the mains supply before cleaning.**

**This appliance is not water proof.**

**Do not use water jet spray to clean interior or exterior of this appliance.**

Clean the Range regularly. A clean appliance looks better, will last longer and will perform better. Carbonised grease on the surface will hinder the transfer of heat from the cooking surface to the food. This will result in loss of cooking efficiency.

**DO NOT use water on the appliance while it is still hot as warping and cracking may occur. Allow the appliance to cool down before cleaning.**

#### NOTE:

- **DO NOT use abrasive detergents, strong solvents or caustic detergents as they could corrode or damage the appliance.**
- **In order to prevent the forming of rust on the hotplate elements (Cast Iron), ensure that any detergent or cleaning material has been completely removed after each cleaning. The appliance should be switched on briefly to ensure the elements become dry. Oil or grease should be wiped over the hotplate surfaces in order to form a thin protective greasy film.**

To keep your Range clean and operating at peak efficiency, follow the procedures shown below:-

#### **After Each Use**

Clean the Cooktop with a soft scrubbing brush to remove any food debris.

#### **Daily Cleaning**

1. Thoroughly clean the splash back, the interior and exterior surfaces of the appliance with hot water, a detergent solution and a soft scrubbing brush.
2. Clean the Control Panel with a damp cloth lightly moistened with a solution of mild detergent and water. Dry the control panel thoroughly with a dry cloth and polish with a soft dry cloth.
3. Brush the hotplate surfaces with a soft bristled brush. Any carbon deposits should be removed using a scraper tool, followed by wiping with a cloth moistened with a solution of mild detergent and hot water to prevent accumulation of food deposits.
4. Dry the appliance thoroughly with a dry cloth and polish with a soft dry cloth.

### Weekly Cleaning

**NOTE:**

- If the Range usage is very high, we recommend that the weekly cleaning procedure is carried out on a more frequent basis.
- Ensure that protective gloves are worn during the cleaning process.
- **DO NOT** use harsh abrasive detergents, strong solvents or caustic detergents as they will damage the Cooktop and elements.
- **DO NOT** use water on the hotplates while they are still hot as warping may occur. Allow these castings to cool for cleaning.

**NOTE:** In order to prevent the forming of rust on the hotplates, ensure that all detergent and cleaning material has been entirely removed after each cleaning process. The appliance should be switched on briefly to ensure the hotplates become dry. Oil or grease should be wiped over the hotplate surfaces in order to form a thin protective greasy film.

### Cooktop Cooking Area

- a. Clean the Cooktop area with a soft cloth and a mild detergent and hot water solution.
- b. Baked on deposits or discolouration may require a good quality stainless steel cleaner or stainless steel wool. Always apply cleaner when the appliance is cold and rub in the direction of the grain.

### Stainless Steel Surfaces

- a. Clean the exterior surfaces of the Cooktop with hot water, a mild detergent solution and a soft scrubbing brush. Note that the control knobs are a push fit onto the control spindles and can be removed to allow cleaning of the front control panel.
- b. Baked on deposits or discolouration may require a good quality stainless steel cleaner or stainless steel wool. Always apply cleaner when the appliance is cold and rub in the direction of the grain.
- c. To remove any discolouration, use an approved stainless steel cleaner or stainless steel wool. Always rub in the direction of the grain.
- d. Dry all components thoroughly with a dry cloth and polish with a soft dry cloth.

### Periodic Maintenance

To achieve the best results, cleaning must be regular and thorough and all controls and mechanical parts checked and adjusted periodically by a competent serviceman. If any small faults occur, have them attended to promptly. Don't wait until they cause a complete breakdown. It is recommended that the appliance is serviced every 6 months.

## Fault Finding

---

This section provides an easy reference guide to the more common problems that may occur during the operation of your appliance. The fault finding guide in this section is intended to help you correct, or at least accurately diagnose problems with your equipment.

Although this section covers the most common problems reported, you may encounter a problem not covered in this section. In such instances, please contact your local authorised service agent who will make every effort to help you identify and resolve the problem. Please note that the service agent will require the following information:-

- The **Model Trade Name** and the **Serial Number** of the Appliance. (Both can be found on the Technical Data Plate located on the appliance)

<b>Fault</b>	<b>Possible Cause</b>	<b>Remedy</b>
Element does not work when turned 'ON'.	Check for an electrical short by checking that there is NO continuity between any "phase in" line and the metal appliance body itself.  Check for the item failing (element, control etc) using a multimeter.	Call the service provider.  Call the service provider.
Complete power failure of the appliance	Check fuse connection at the mains supply.  Ensure that the fuse size is correct to carry the load.  Check for an electrical short to the appliance.	Replace the blown fuse.  Carry out a continuity and resistance check on the appliance.  Call the service provider.

## Static Ovens (RN8610SE Series)

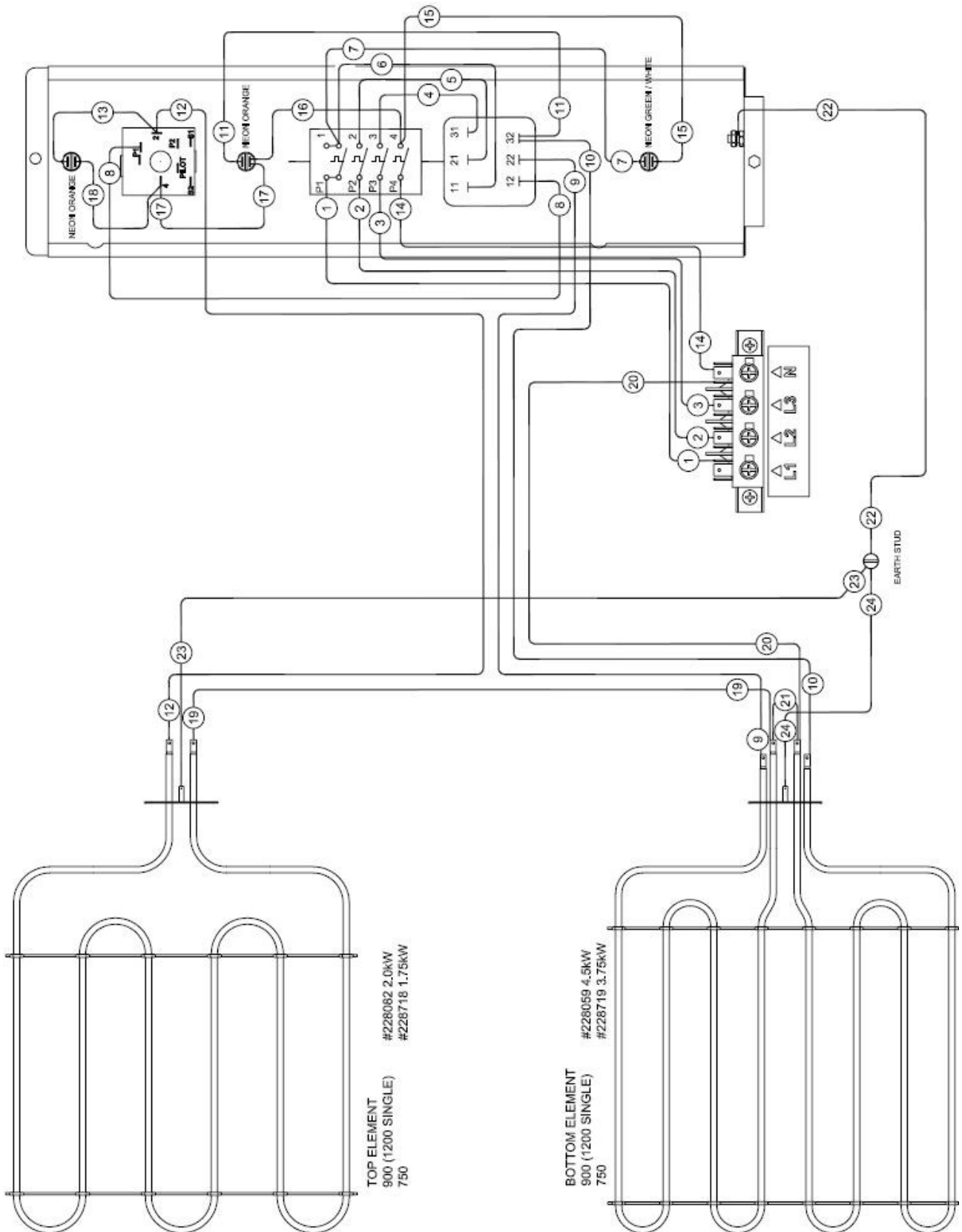

# Wiring Diagrams

## Convection Ovens (RN8610SEC Series)

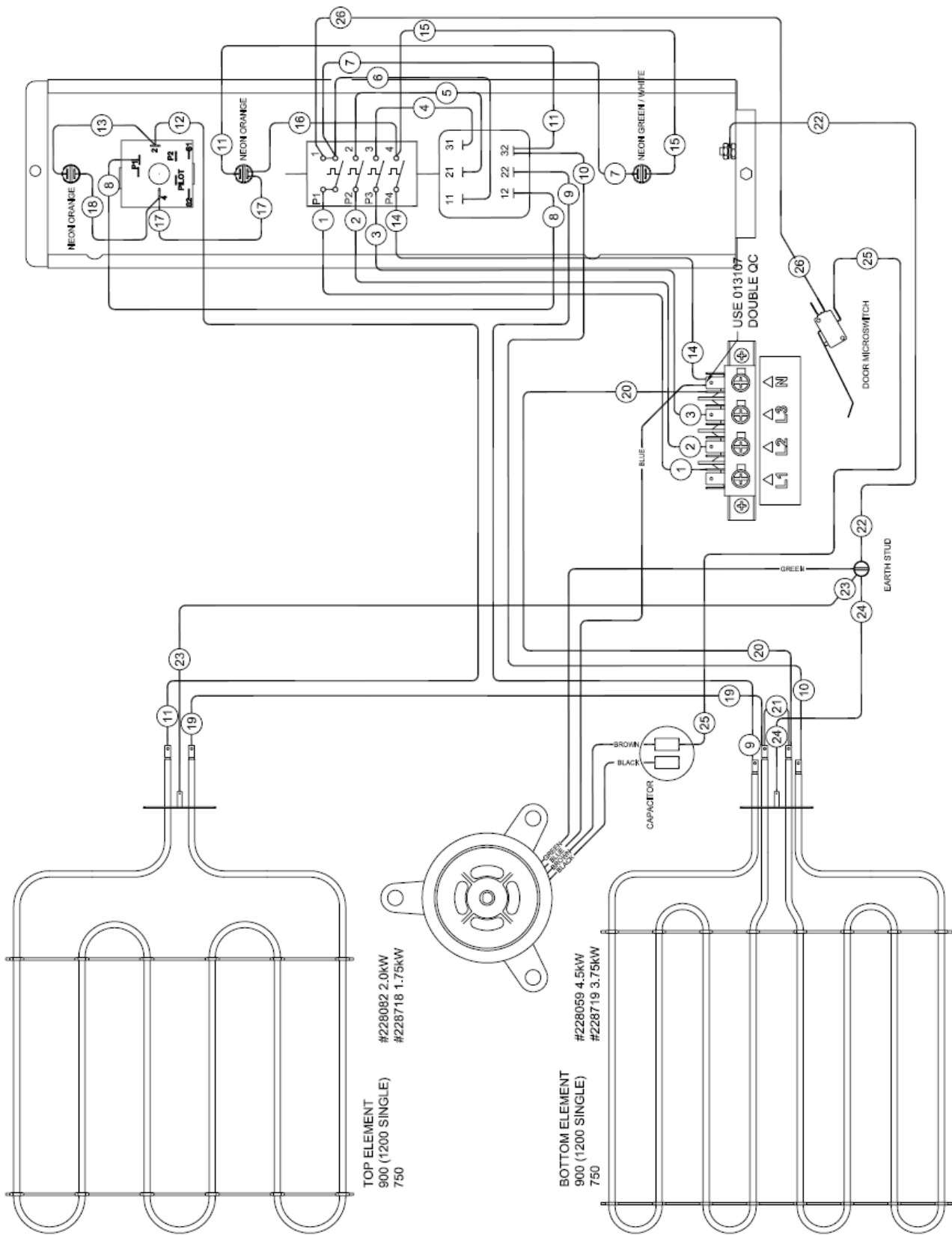



## Cooktop - 6 Elements (RN8610SE/SEC Models)

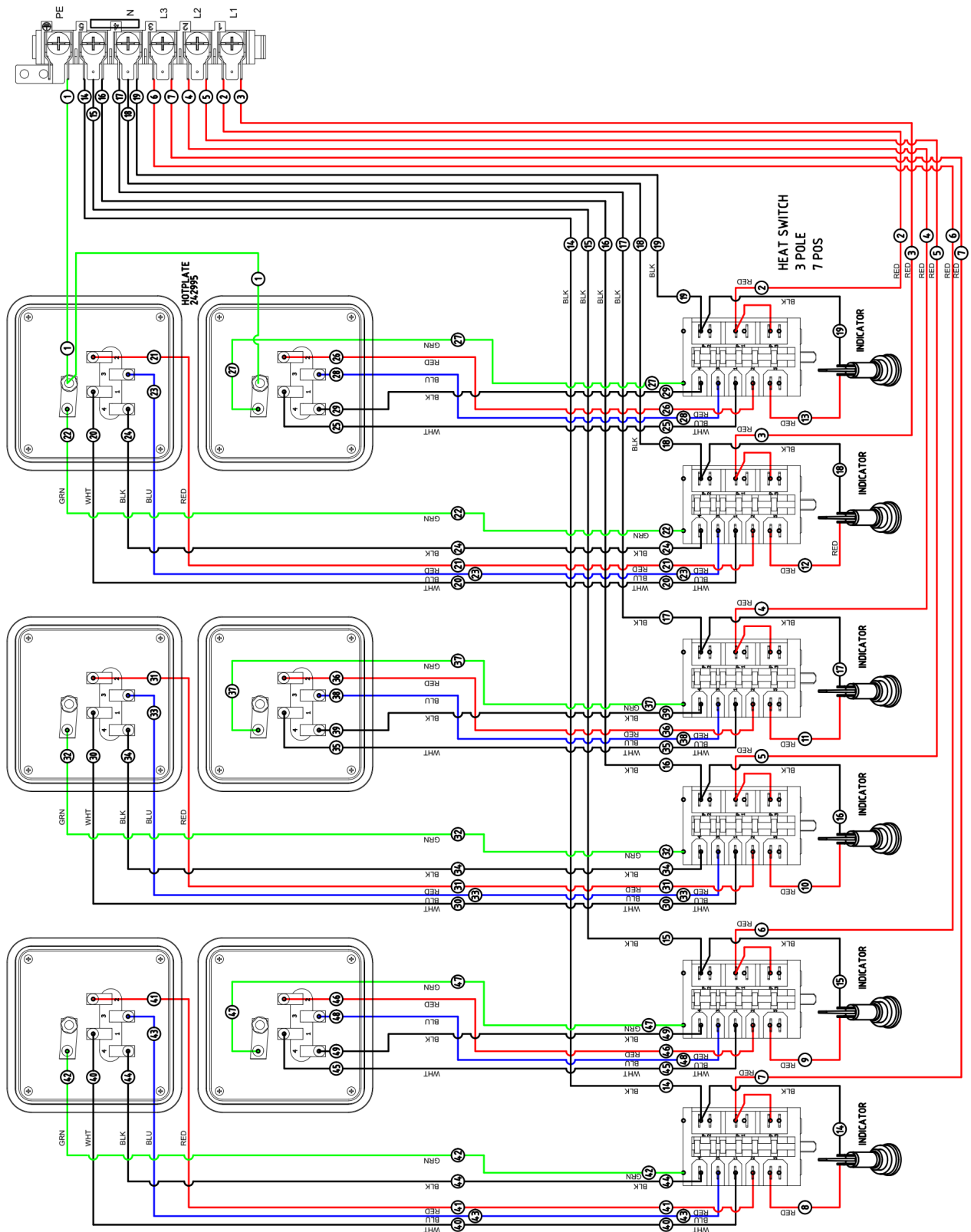

# Circuit Schematics

## Wiring Layout for Static Oven

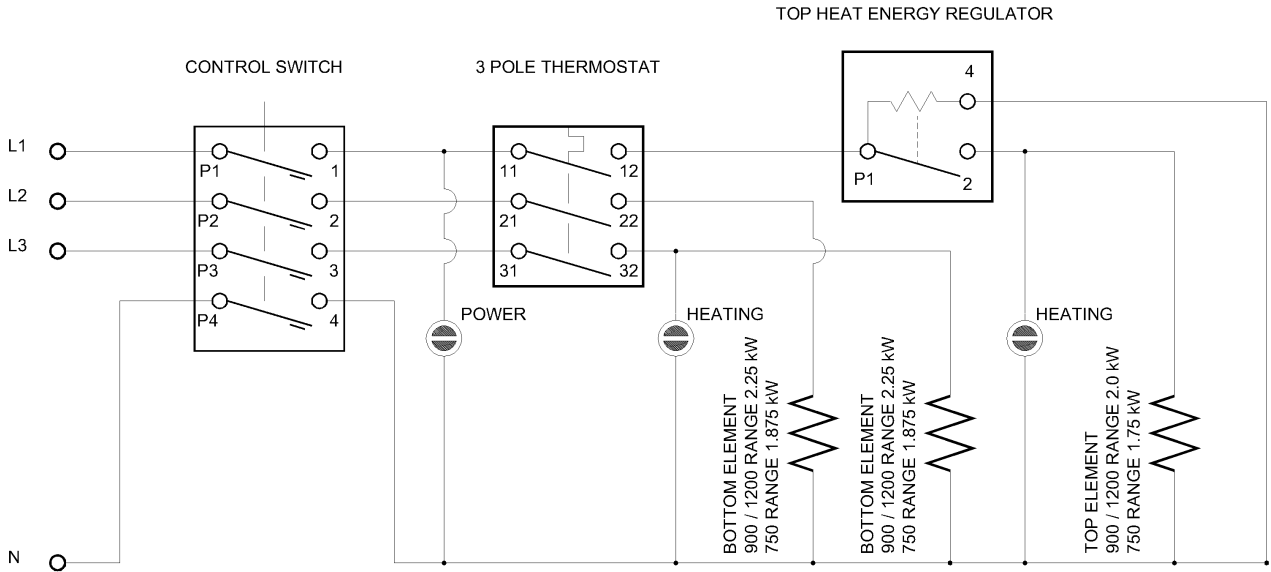

## Wiring Layout for Convection Oven

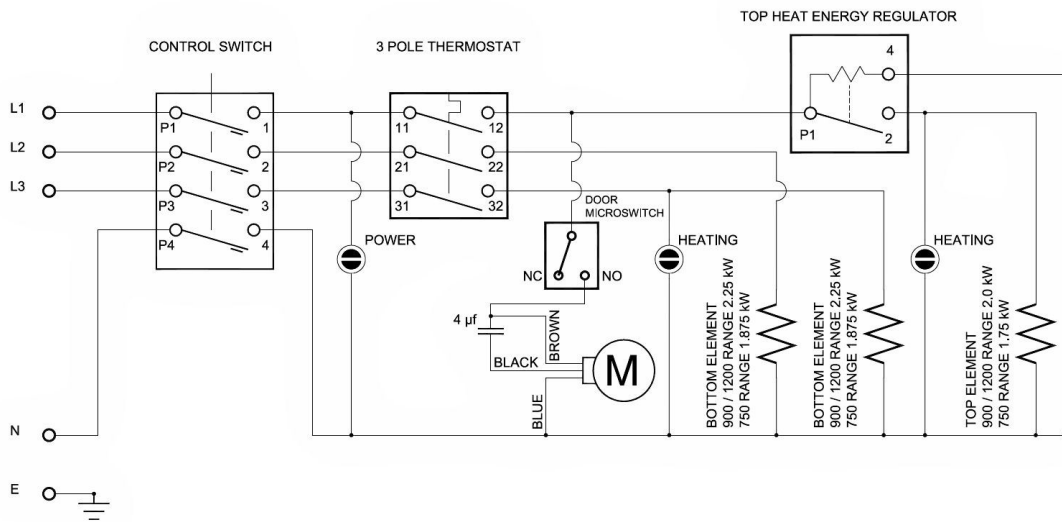

## Wiring Connection Between Oven and Hob

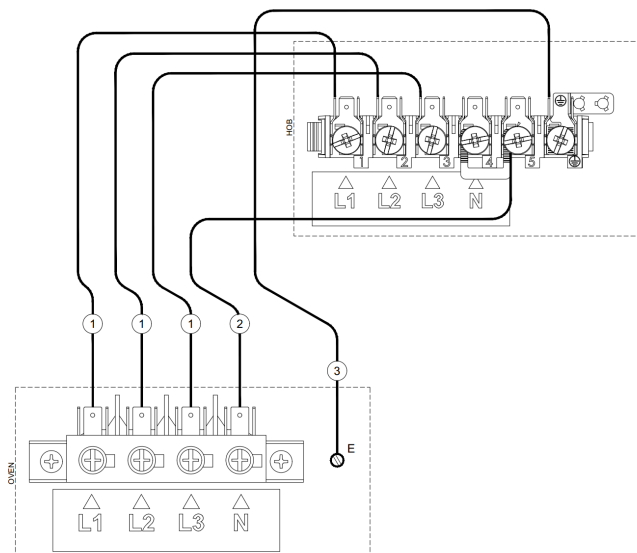

## Replacement Parts List

### **IMPORTANT:**

Only genuine authorized replacement parts should be used for the servicing and repair of this appliance. The instructions supplied with the parts should be followed when replacing components.

For further information and servicing instructions, contact your nearest authorized service branch (contact details are as shown on the reverse of the front cover of this manual).

When ordering replacement parts, please quote the part number and the description as listed below. If the part required is not listed below, request the part by description and quote the model number and serial number which is shown on the rating plate.

### **Cooktop**

247734	Element Wire Loom
242995K	Hotplate Element 220x220RI 2.6kW 240V Kit
238765	Indicator Green
248171	Control Knob HI/LO
247717	Switch 6 Heat 7 Position

### **Oven**

228082K	Oven Top Element 2kW 240V Kit
228059	Oven Bottom Element 4.5kW
228704	Door Spring Kit (Includes 2 Springs)
229146	Thermostat 50 - 300°C
229145	Switch (4-pole)
013989	Energy Regulator
227398	Control Knob HI/LO Heat
227399	Control Knob Thermostat 50°C - 300°C
227963	Neon Orange
227962	Neon Green

### **Convection Oven Only**

228938	Oven Door Microswitch
010909	Motor Capacitor 4µf
019479K	Motor Kit (Includes Cooling Disc & Capacitor 4µf)
010866	Cooling Disc
228116	Fan

### **General**

227892	Oven Side Rack LH
227893	Oven Side Rack RH
227896	Oven Rack
240534	Adjustable Leg - 150mm c/w Plate (Front)
227850	Adjustable Leg - 150mm (Rear)
229674	Rear Roller Assy
228571	Index Mark Moulding

### **Accessories**

228799	900mm Plinth Kit
--------	------------------

