

DR Robot Automatic

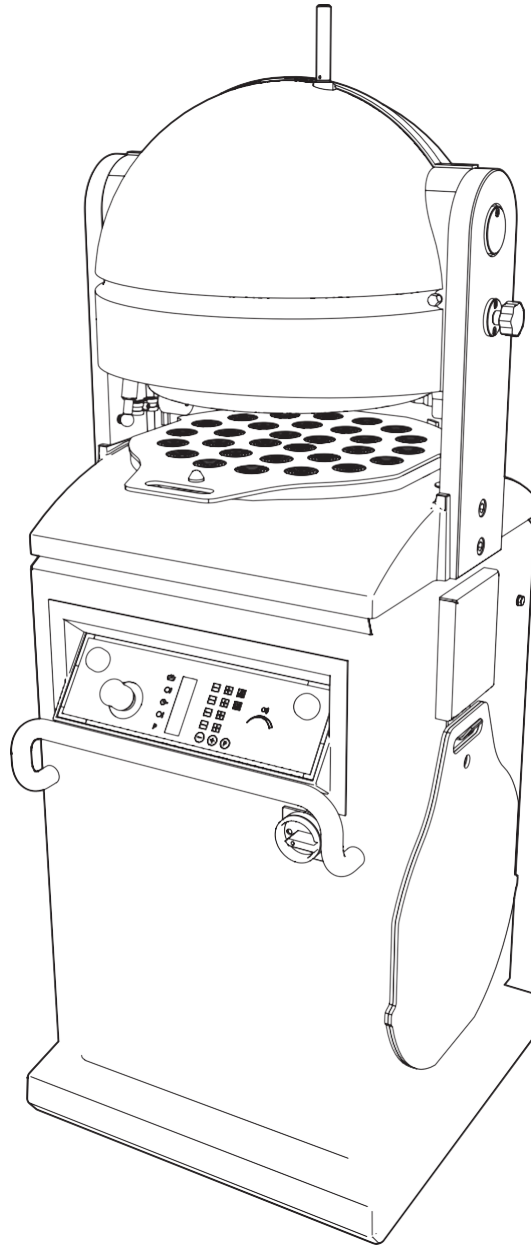

INSTALLATION AND OPERATION MANUAL

Contacts

MANUFACTURED BY

Moffat Limited
Rolleston 7675
New Zealand

INTERNATIONAL CONTACTS

AUSTRALIA

Moffat Pty Limited

Web:

E.Mail:

Main Office:

Service:

Spares:

Customer Service:

www.moffat.com.au

vsales@moffat.com.au

(tel) +61 (03) 9518 3888

(fax) +61 (03) 9518 3833

(tel): 1800 622 216

(tel): 1800 337 963

(tel): 1800 335 315

(fax): 1800 350 281

CANADA

Serve Canada

Web:

E.Mail:

Sales:

Service:

www.servecanada.com

info@servecanada.com

(tel): 800 551 8795 (Toll Free)

(tel): 800 263 1455 (Toll Free)

NEW ZEALAND

Moffat Limited

Web:

E.Mail:

Main Office:

www.moffat.co.nz

sales@moffat.co.nz

(tel): 0800 663328

UNITED KINGDOM

Blue Seal

Web:

E.Mail:

Sales:

Spares:

Service:

www.blue-seal.co.uk

sales@blue-seal.co.uk

(tel): +44 121 327 5575

(fax): +44 121 327 9711

(tel): +44 121 322 6640

(fax): +44 121 327 9201

(tel): +44 121 322 6644

(fax): +44 121 327 6257

UNITED STATES

Moffat

Web:

Sales:

Service:

www.moffat.com

(tel): 1-800 551 8795 (Toll Free)

(tel): 336 661 1556

(fax): 336 661 9546

(tel): 866 673 7937 (Toll Free)

REST OF WORLD

Moffat Limited

Web:

E.Mail:

www.moffat.co.nz

export@moffat.co.nz

The reproduction or copying of any part of this manual by any means whatsoever is strictly forbidden unless authorized previously in writing by the manufacturer.

In line with policy to continually develop and improve its products, Moffat Ltd. reserves the right to change the specifications and design without prior notice.

© Copyright Moffat Ltd. May 2026.

General Safety Information

General Safety Information

CE Only:

These instructions are only valid if the country code appears on the appliance. If the code does not appear on the appliance, refer to the supplier of this appliance to obtain the technical instructions for adapting the appliance to the conditions for use in that country.



Safety alert symbol.
When you see this symbol in the manual or on the appliance, pay special attention to the instructions.



Read the instructions before using this appliance.



Risk of electric shock.



WARNING

Improper installation, adjustment, alteration, service or maintenance can cause property damage, injury or death. Read the installation, operating and maintenance instructions thoroughly before installing or servicing this appliance.



WARNING

- Great care must be taken by the operator to use the equipment safely.
- The appliance must NOT be left on unattended.
- It is recommended that a regular inspection is made by a competent serviceman to ensure correct and safe operation of your appliance is maintained.
- DO NOT store or use gasoline or other flammable vapours or liquids in the vicinity of this or any other appliance.
- Do not spray aerosols in the vicinity of this appliance while it is in operation.
- Do not use water jet, spray, or steam cleaner to clean this appliance.



CAUTION

This appliance is intended for commercial use only, in kitchens of restaurants, canteens, and so on. It is not intended to be used as follows:

- In residential, outdoor, marine environments, or for the continuous mass-production of food.
- By persons with limited physical, sensory, or mental abilities.
- By persons who are not adequately trained in the operation and use of the appliance.
- By children.

Contents

Contents

Preface	6
<i>Copyright</i>	6
<i>Disclaimer</i>	6
Introduction	7
<i>Intended readers</i>	7
<i>Symbols in this manual</i>	7
<i>Terminology</i>	7
Machine description	8
<i>Intended and unintended use</i>	8
<i>Description of operation</i>	8
<i>Main components</i>	8
<i>Control panel</i>	9
<i>Working environment</i>	10
<i>Specifications</i>	10
<i>Warranty</i>	11
<i>Conformity</i>	11
Safety	12
<i>Safety provisions</i>	12
<i>Safety instructions</i>	12
Transport and storage	14
<i>Safety instructions</i>	14
<i>Transporting the machine</i>	14
<i>Storing the machine</i>	14
Installation	15
<i>Safety instructions</i>	15
<i>Unpacking the machine</i>	15
<i>Positioning the machine</i>	15
<i>Connecting the machine</i>	15
Commissioning	16
<i>Safety instructions</i>	16
<i>Checking rounding plates</i>	16
<i>Checking electrical connection</i>	16
<i>Switching on the machine</i>	16
<i>Checklist</i>	16

Contents

Use	17
<i>Safety instructions</i>	17
<i>Selecting a program</i>	17
<i>Placing the dough on the rounding plate</i>	17
<i>Placing the rounding plate in the machine</i>	18
<i>Starting the rounding process</i>	18
<i>Saving a program</i>	18
<i>Assessing the result</i>	19
<i>Changing the dividing disc</i>	20
Maintenance	24
<i>Safety instructions</i>	24
<i>Maintenance schedule</i>	24
<i>Cleaning the dividing knife and dividing disc</i>	25
<i>Cleaning under the rounding table</i>	26
<i>Spare parts</i>	26
Troubleshooting	27
<i>Problems, causes and solutions</i>	27
<i>Error notifications</i>	28
Taking out of operation	29
<i>Disconnecting the machine</i>	29
Disposal	30
<i>Disposing of the machine</i>	30

Preface

Preface

Thank you very much for choosing a MOFFAT product which was completely developed, designed, engineered, manufactured, controlled and inspected by Moffat.

For correct use and prolonged lifespan it is important to read our manual and to comply with the suggestions, recommendations and / or regulations when unpacking, installing, using and maintaining the machine. If the machine is sold on, this manual should be handed over to the new owner.

Only employees who have been instructed concerning the use of this machine and who have read this manual may operate this machine.

It is recommended that you always keep this manual close to or with the machine.

Moffat would like to thank you for your trust and wish you maximum job satisfaction with the use of this MOFFAT product.

Copyright

No part of this publication may be reproduced, duplicated or distributed without the prior written permission of the manufacturer.

Disclaimer

Moffat cannot be held responsible for mistakes and/or misprints in this manual.

Introduction

Introduction

Intended readers

The machine must only be operated by qualified personnel with a minimum age of 16 years, who have been instructed in the use of this machine and have read this manual.

Symbols in this manual

The following symbols are used in this manual:

 **WARNING** This symbol indicates a dangerous situation that could result in serious injury or death if the corresponding instructions are not followed.

 **CAUTION** This symbol indicates a dangerous situation that could lead to injury or damage to the machine if the corresponding instructions are not followed.

NOTICE This symbol indicates useful information that is not related to a dangerous situation.

Terminology

The following terminology is used in this manual:

Divider rounder A machine that can cut dough into small parts and round the pieces.

Rounding Forming one piece of dough into more balls.

Dividing Dividing one piece of dough into several pieces.

Machine description

Machine description

Intended and unintended use

The machine (depending on the type) is designed to divide and round lightly pre-proofed dough of up to 4 kg. The machine is only intended for the applications described in this manual. The following applications are considered unintended use:

- Dividing and rounding frozen or not fully thawed dough.
- Dividing and rounding dough containing hard or large nuts and seeds.

Description of operation

The dough to be rounded is placed on the rounding plate and lightly spread out. The dough may be lightly dusted with flour to achieve a good rounding result. When the dough is removed from the machine after processing, the dividing and rounding process is complete.

The parts that come into contact with dough have a Teflon coating, consist of stainless steel, anodized aluminium or are made of plastics suitable for the food industry.

Main components

Figure 1 shows the main components.

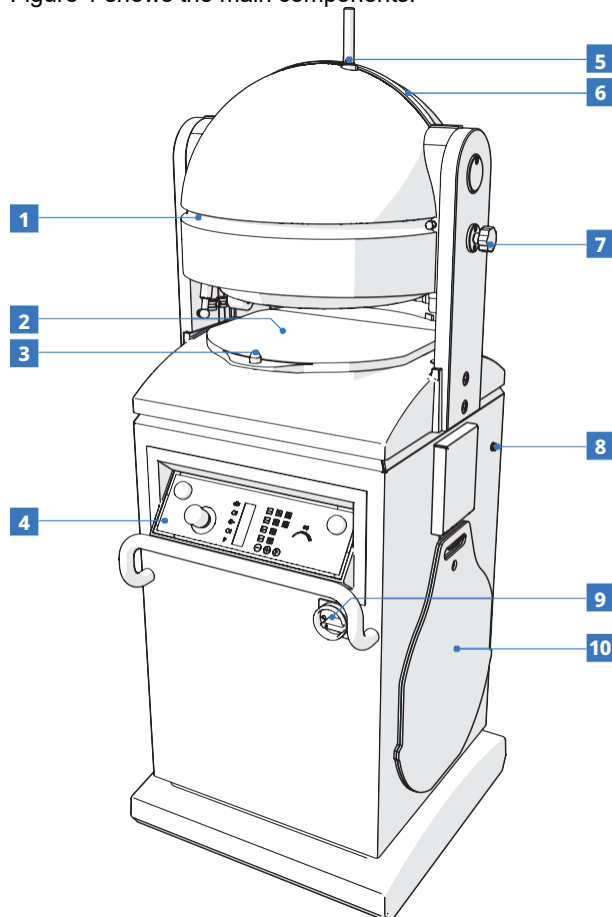

Figure 1 Main components

No.	Component	Function
1	Front cover	The front cover shields the dividing disc and dividing knife.

Machine description

2	Rounding table	The rounding table supports the rounding plate during processing by the machine.
3	Centring pin	The centring pin locks the rounding plate during processing by the machine.
4	Control panel	The machine is operated from the control panel.
5	Volume bar	The settings of the weight determines how far the dividing disc moves up during rounding. In this way the volume of the rounding chambers can be determined. Therefore this position is related to the weight of the dough piece that should be divided.
6	Rear cover	The rear cover shields the dividing disc and dividing knife.

Control panel

Figure 2 shows the control panel.

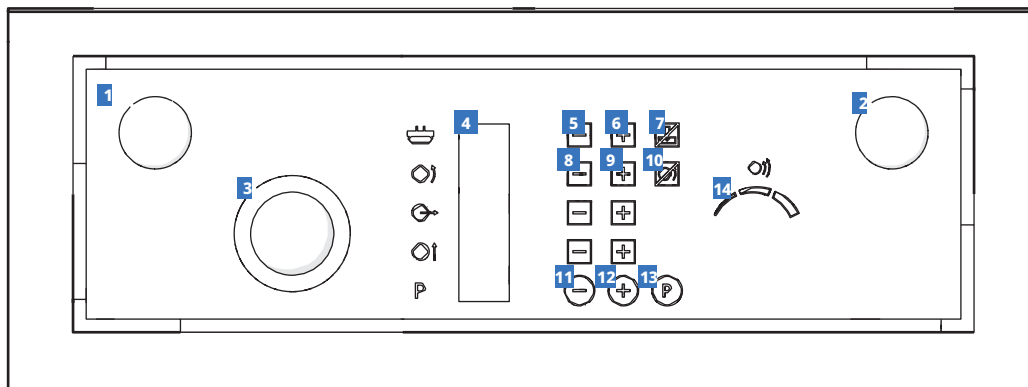

No.	Component	Function
1	Start button left	With the start buttons left and right you give the general start command. The work cycle will be automatically completed. Press both start buttons simultaneously.
2	Start button right	
3	Emergency stop	Pressing the emergency stop gives a stop command to the machine. The message 'E5' appears on the display. The emergency stop must only be used in emergencies. Normally, the machine will end its cycle on its own by working through the internal and entered external parameters.
4	Display for announcements and settings	
5	(-) key to decrease the pressing time	The pressing time can be changed by operating the keys 5 and 6, and is set in seconds
6	(+) key to increase the pressing time	The value is depending on the amount of dough as well consistency.
7	Program-key for pressing only	With Key 7 the machine will press only; the dough will be pressed out only without cutting. In the display will appear "PRS".
8	(-) key to decrease the rounding time	The amount of rounding can be set by changing the timing through buttons 8 and 9; the longer the more the dough will be stressed. The setting is depending on type of dividing disc; the amount of dough as well consistency.
9	(+) key to increase the rounding time	
10	Off key; to switch off rounding	For dough types which should only be cut, through key 10 (Off-key) the rounding time can be switched off. Now the machine will only divide.
11	(-) key to decrease program number	With the buttons 11 and 12 program 1 to 10 can be set in which all digital values mentioned above can be stored for reproduction.

Machine description

12	(+) key to increase program number	
13	P-key to store settings	Changed variables can be saved by pressing key 13 (P-key). The letter 'P' will light up on the display to indicate the action.
14	Variable pressure control	Potential meter to regulate the pressure

Working environment

To operate the machine, a working area of 0.6 metres is required around the machine. All operating, maintenance and repair operations can be carried out in this area.

Specifications

Technical specifications

The name plate is located on the side of the machine. Figure 3 shows the name plate.

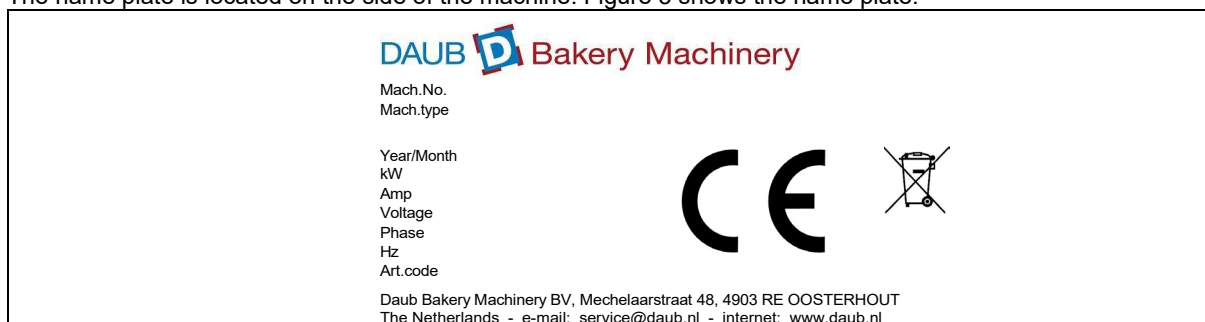

Figure 3 Name plate

Machine name	DR Robot Automatic
Machine number	See type plate
Date of manufacturing	See type plate
Dimensions	620 × 670 × 1700 mm
Weight	345 kg
Sound	<65 dB(A)
Power	See type plate
Voltage	See type plate
Current	See type plate
Available voltages	400-460V / 50-60Hz / 3 phase+N 400-460V / 50-60Hz / 3 phase 200-270V / 50-60Hz / 3 phase Other voltages on request
Temperature	15 °C to 40 °C
Relative humidity	20% to 95%
Rounding plates	Plastic Trovidur
Dividing disc	Anodized Aluminium

Machine description

Dividing knife	Stainless steel
Press ring	Teflon coated cast iron
Rounding table	Aluminium
Hydraulic oil	Unil HVD 32
Optional	Foodslip Hydraulic Oil Anderol FGH 32

Note: All parts, which could come in contact with the dough, are food approved

Available dividing discs

Dividing disc	Division	Max. weight	Weight range
DR2-90-2/30	30 pieces	2.5 kg	25-85 grams*
DR2-90-3/30	30 pieces	3 kg	30-100 grams*
DR2-90-3/36	36 pieces	3 kg	25-85 grams*
DR2-90-3/52	52 pieces	3 kg	16-45 grams*
DR2-90-4/09-F	9 pieces	4 kg	100-440 grams*
DR2-90-4/14	14 pieces	4 kg	130-250 grams*
DR2-90-4/30	30 pieces	4 kg	40-130 grams*
DR2-90-4/36	36 pieces	4 kg	30-110 grams*

*) The weight range depends on the dough consistency.

Warranty

Moffat will accept no liability for defects which have occurred because of the incorrect use of the machine. Neither will Moffat be held responsible for any damage or injuries to operators or to third persons if deemed to be caused by the incorrect use of the machine.

Guarantee can not be claimed if changes have been made to the machine without the manufacturers permission and/or if non-original spare parts are used. The use of not-original spare parts can damage the machine and/or harm the operator.

Conformity

Moffat Bakery Machinery B.V. machines conform to the requirements of the following EC directives:

- Machinery Directive 2006/42/EC
- Low Voltage Directive 2014/35/EC
- EMC Directive 2014/30/EC
- Regulation (EC) 1935/2004

The declaration of conformity is supplied separately with the machine. More information can be found in this document.

Safety

Safety

Safety provisions

Emergency stop

Pressing this emergency stop gives a stop command to the machine. The message 'E5' appears on the display. The emergency stop must only be used in emergencies. Normally, the machine will end its cycle on its own by working through the internal and entered external parameters.

Safety symbols and markings on the product



Figure 4 Entrapment hazard

Figure 4 shows a sticker affixed to the machine to indicate the presence of an entrapment hazard.

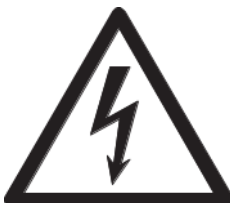

Figure 5 Electrical hazard

Figure 5 shows a sticker attached to the machine to indicate that electricity is present.

Personal protective equipment



Figure 6 Protective gloves

Figure 6 shows a sticker indicating that the user must wear protective gloves while servicing the machine and working with sharp parts.

Safety instructions

WARNING

For correct use and prolong lifespan it is important to read our manual and to comply with the suggestions, recommendations and / or regulations when unpacking, installing, using and maintaining the machine. If the machine is sold on, this manual should be handed over to the new owner.

Transport and storage

WARNING

- Do not load anything on the top of the packing.
- The machine should always be transported upright.
- Net weight of the machine is approximately 345 kg.
- Transport damage caused by not having followed above-mentioned regulations cannot be claimed. Moreover transport of goods is always at the buyers risk, unless explicitly agreed otherwise.

Safety

Installation

WARNING

- Out of safety considerations it is advisable to keep enough distance when lifting the machine.
- Be sure the machine is placed on a flat floor.
- Install the machine in a well-ventilated area to prevent the accumulation of unacceptable concentrations of particles harmful to health.
- Have the machine installed by qualified personnel.
- Do not adjust parts the manufacturer has sealed with paint. Have these parts adjusted by qualified personnel.
- Do not use extension leads to connect the machine to the mains.
- Make sure that the warning stickers stay in good condition, and if necessary replace them.

Commissioning

WARNING

Only qualified employees older than 16 years may operate the machine.

Use

WARNING

- Never put your hands in the working area of the machine.
- The machine can only be used when the safety covers are placed.
- Do not use dough or other products with metals, stones or other peculiar objects inside.
- Do not use the machine if a fault message is shown on the display.
- Only one person may use the machine.

Maintenance

WARNING

- Always turn the main switch to "0" (off) before starting any kind of maintenance.
- Never clean the machine with water. The use of water will cause oxidation and electrical problems.
- Only qualified employees may clean the machine.
- Only use original spare parts.
- Keep hands on the front of the dividing disc when rotating backwards after cleaning. Otherwise, your hands may become trapped.

CAUTION

- Other persons should keep some distance.
- Use only cleaning agents permitted in the food industry.

Transport and storage

Transport and storage

Safety instructions

 **WARNING**

Carefully read the safety instructions in section 3. before transporting the machine. This will prevent possible personal injury or damage to the machine.

Transporting the machine

Required tools

- Forklift or crane

Instructions

- Transport the machine in its original packaging.
- Secure the packaging against sliding in the transport vehicle.
- Move the machine by forklift or crane.

Storing the machine

Protect the machine from external influences, and store it in an enclosed, dry area. Store the machine in the following conditions:

Temperature	15 °C to 40 °C
Relative humidity	20% to 95%

Installation

Installation

Safety instructions

 **WARNING**

Carefully read the safety instructions in section 3. before installing the machine. This will prevent possible personal injury or damage to the machine.

Unpacking the machine

1. Make sure the packaging is upright.
2. Remove the box vertically.
3. Carefully unpack the machine.
4. Check the machine for transport damage.

NOTICE

If you find any damage, inform your carrier immediately. We recommend taking photos of the damage.

Positioning the machine

NOTICE

The machine should be placed on a solid and flat floor. The machine is very stable. In case of a very slippery floor, you can block the wheels by using wedges.

Required tools

- Forklift

Instructions

1. Slide the forklift's fork under the base of the machine.
2. Lift the machine.
3. Drive to the desired location of the machine.
4. Lower the machine.
5. Remove the forklift's fork from under the base of the machine.

Connecting the machine

- A fuse with switch is placed within two metres of the machine.
- A cable gland with clamping ring is fitted around the power supply cable at the cable entry opening in the machine.
- The voltage and phases of the electrical connection are the same as those of the machine (see type plate on the side of machine). Contact your supplier if this is not the case.
- Connect the power supply cable.

NOTICE

- The machine must be connected to a group protected by a class 1, type C residual-current circuit breaker.
- The electrical diagram has been added to the switch box of the machine and can be requested from Daub.

Commissioning

Commissioning

Safety instructions

WARNING

Carefully read the safety instructions in section 3. before commissioning the machine. This will prevent possible personal injury or damage to the machine.

Checking rounding plates

Check that the supplied rounding plates fit properly. These must fall over the centring pin of the rounding table without any difficulty.

Checking oil level in hydraulic tank

Check the oil level in the hydraulic tank. The oil reservoir must be 75% full. If not, top up the tank with hydraulic oil with a viscosity of 32.

Checking electrical connection

Check the direction of rotation of the machine.

1. Turn the power on.
2. Press and hold the two start buttons simultaneously until the pressing ring is completely against the rounding plate.

The dividing disc will come down and the table will start performing an eccentric movement.

If this does not all happen, two phases in the plug connection must be swapped (by an electrician) to change the direction of rotation of the motors.

Switching on the machine

Turn the power on.

Checklist

- Check if the machine is placed correctly as described in chapter 5.3.
- Check if it is necessary to clean the machine because of possible transport dirt.
- Clean the dividing disc before use and lightly lubricate it with oil (see also section 8.3.). From the factory, the dividing disc is lightly oiled.
- Check that the voltage on the type plate matches the available mains voltage.
- Be sure the machine is placed on a solid and flat floor.

Use

Use

Safety instructions

WARNING

Carefully read the safety instructions in section 3. before using the machine. This will prevent possible personal injury or damage to the machine.

Selecting a program

Choose a desirable program and set the volume bar according type of dough and required weight.

Setting	Type 2/xx	Type 3/xx	Type 4/xx
0	750	900	1200
1	1110	1320	1550
2	1470	1740	1900
3	1830	2160	2250
4	2190	2580	2600
5	Max.	Max.	2950
6			3300
7			3650
8			Max.

NOTICE

- The settings of the weight determines how far the dividing disc moves up during rounding. In this way the volume of the rounding chambers can be determined. Therefore this position is related to the weight of the dough piece that should be divided.
- As the correct setting depends on the dough consistency, it is a question of experience.
- When the setting is too low, the dough pieces will be damaged. When the setting is too high, they will not be sufficiently rounded.

Placing the dough on the rounding plate

Place the dough piece in the middle of the rounding plate and flatten it by hand.

NOTICE

- If the dough is very stiff it is useful to flatten the dough by a dough roller.
- In case of sticky dough it is advisable to flour the dough and rounding plate lightly

Use

Placing the rounding plate in the machine

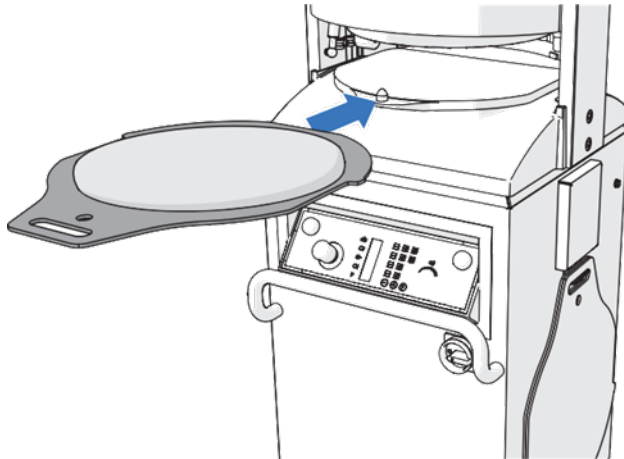

Figure 7 Place the rounding plate

Place the rounding plate correctly on the rounding table. See Figure 7.

⚠ CAUTION

Inserting the rounding plate improperly can cause damage to the machine.

Starting the rounding process

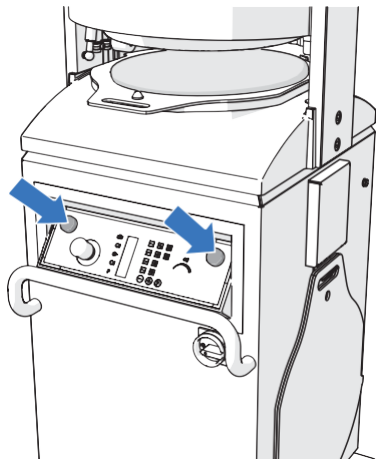

Figure 8 Start the rounding process.

Press and hold the two start buttons simultaneously until the pressing ring is completely against the rounding plate. See figure 8.

The machine will start.

NOTICE

If the start buttons are released prematurely, the ring will move up.

If the result is not satisfactory, the settings can be changed. See section 2.6.2.

Saving a program

Press the P-key to save the current settings under a program number.

NOTICE

The final result depends on the dough consistency. With more experience and use you will attain the best final result. See section 2.6.2.

Use

Assessing the result

The following information will help you to obtain the best possible result.

When operating the machine, always observe the following adjustment options: volume, pressing time and rounding time.

Problem	Solution
The dough balls are not of equal weight.	Make sure the dough piece is put exactly in the middle of the plate and flatten it a little by hand. The dough should not come over the edge of the rounding plate.
	Make sure the dough is pre-proofed for the correct length of time (depends on the dough consistency, but usually 15 minutes).
	Increase the pressing time. The pressing time can be read in the display. As soon as the dough appears under the pressing ring it has been pressed long enough.
The dough balls are not rounded enough.	Reduce the weight setting with the volume bar.
	Increase the rounding time by pushing button 9 on the control panel.
	Try a combination of both.
The dough balls have a point at the top.	Increase the weight setting with the volume bar.
	Check if the dough piece is in accordance with the capacity of the machine.
The surface of the dough balls is cracked.	The dough pieces have been rounded too long. Decrease the rounding time with button 8 on the control panel.
The machine presses the dough through the gap between the rounding plate and the pressing ring.	The dough piece has been pressed too long. Decrease the pressing time.
	The soft dough is being pressed to hard. Lower the pressure (with the option pressure regulation).

NOTICE

For good results, observe the machine's prescribed weight ranges. See the table for the correct weight range.

Use

Changing the dividing disc

Supplied tools

- Pipe spanner

Instructions

1. Turn off the main switch.

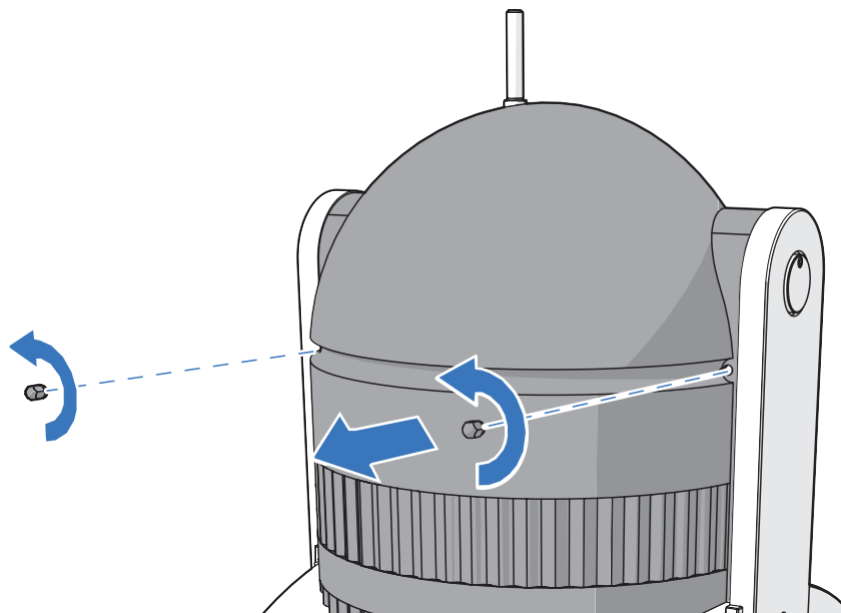
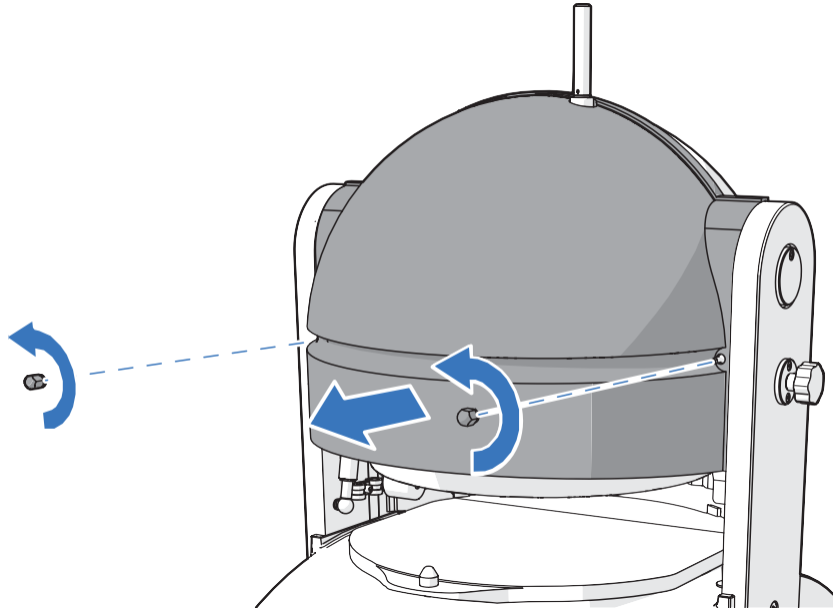

Figure 9 Remove the front and rear covers

Use

2. Remove the front and rear covers with the supplied pipe spanner. See Figure 9.

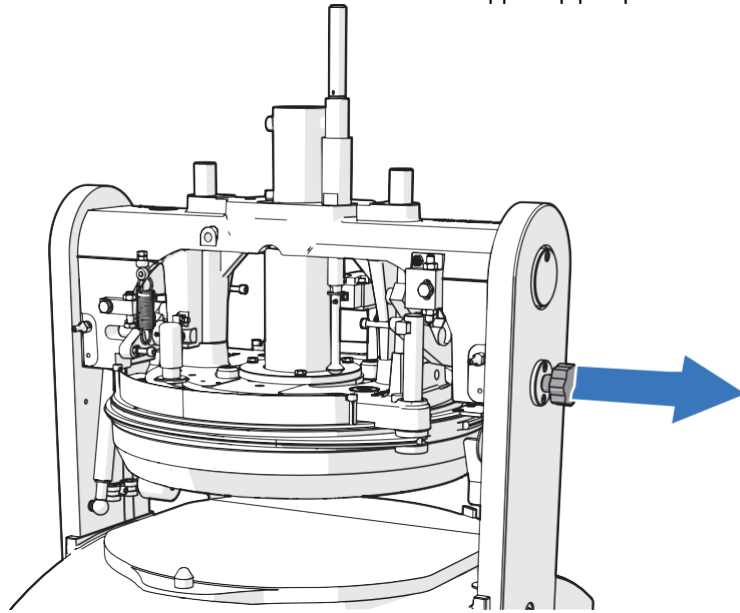

Figure 10 Pull the locking pin out

3. Pull the locking pin out. See Figure 10.

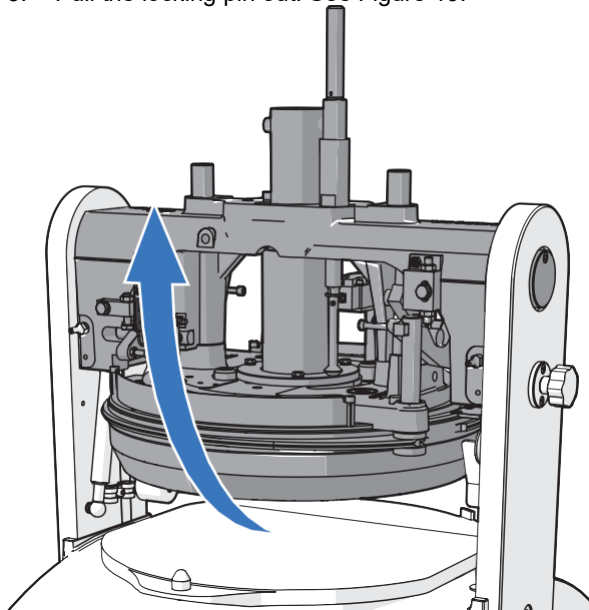

Figure 11 Tilt the dividing disc forward

Use

4. Tilt the dividing disc forwards. See Figure 11. Dividing disc will turn with the help of a gas spring.

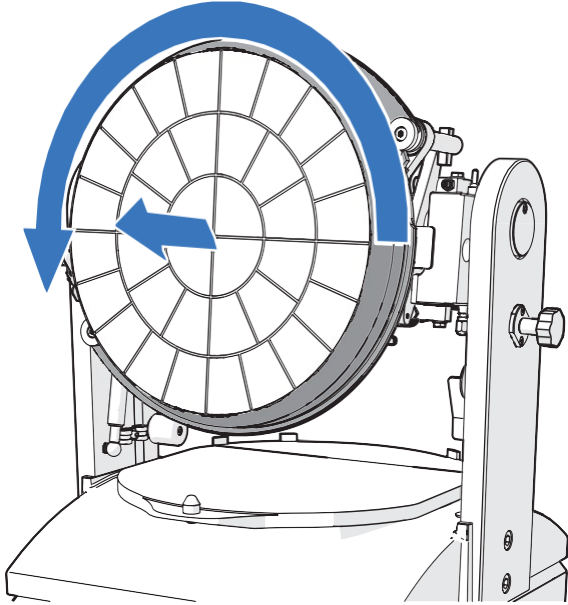

Figure 12 Remove the pressing ring

5. Turn the power on.
6. Press and hold the two start buttons simultaneously until all forward movements complete.
7. Turn the power off.
8. Remove the pressing ring by turning it anticlockwise. See Figure 12.

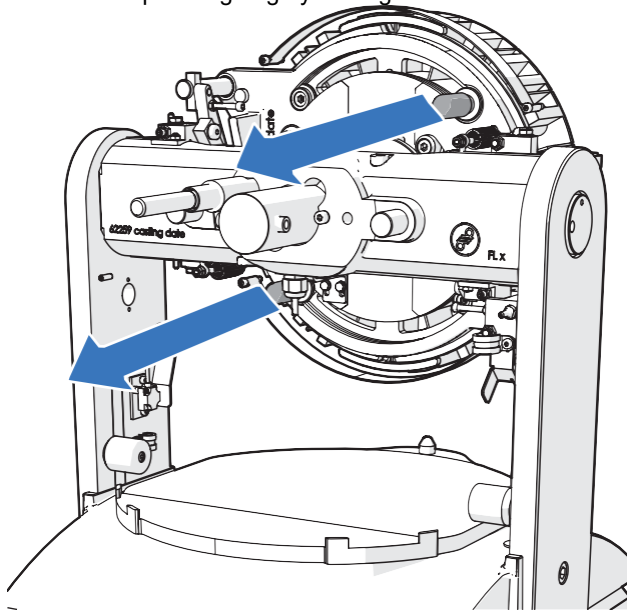

Figure 13 Remove the locking pins from the dividing disc

9. Turn the power on.
10. Press and hold the two start buttons simultaneously until all retracting movements complete.
11. Turn the power off.
12. Remove the two locking pins from the dividing disc. See Figure 13.
13. Rotate the two grips to the outside of the disc.
14. Lock the grips by pushing it into the disc.

Use

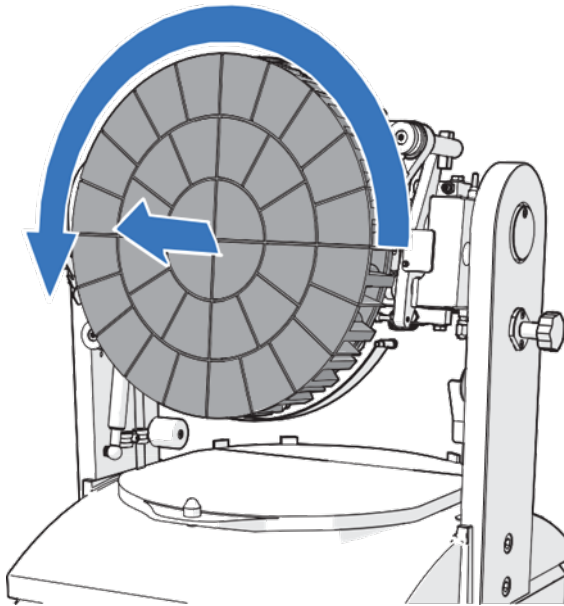

Figure 14 Turn the dividing disc

15. Turn the dividing disc anticlockwise. See Figure 14.
16. Pull disc towards you.

NOTICE

Weight of disc is approx. 13 kg.

17. Insert a dividing disc, either the same one or a different one.
18. Turn the dividing disc clockwise.
19. Unlock both handles by pushing them outwards.
20. Turn the two extended handles on the dividing disc inwards.
21. Insert the two locking pins for the dividing disc.
22. Turn the power on.
23. Press and hold the two start buttons simultaneously until all movements complete.
24. Turn the power off.
25. Fit the pressing ring by turning it clockwise.
26. Turn the power off.
27. Press and hold the two start buttons simultaneously until all retracting movements complete.
28. Turn the power off.
29. Tilt the dividing disc downwards.
30. Push the locking pin back in.
31. Fit the front and rear cover.

NOTICE

Also replace the rounding plate if dividing disc is replaced for another type with different division

Maintenance

Maintenance

Safety instructions



WARNING

- Carefully read the safety instructions in section 3. before servicing the machine. This will prevent possible personal injury or damage to the machine.
- Only qualified personnel may carry out other maintenance on the machine.

Maintenance schedule

Required tools

Cold to lukewarm water
Brush
Damp cloth
Plastic scraper
Compressed air
Grease
Hydraulic oil
Pipe spanner

Instructions

Frequency	Instructions
Daily	Clean all used rounding plates (do not forget to clean the bottom as well) with cold to lukewarm water.
	Do not store the rounding plates in the machine, but hang them on the side brackets of the machine.
	Clean the top of the rounding table with a brush, damp cloth, plastic scraper or compressed air.
Weekly	Clean the working area of the dividing disc, knife and pressing ring (see section 8.3.) with a brush, damp cloth, plastic scraper or compressed air.
Monthly	Grease all moving parts of the head. Pay particular attention to the two console shafts 1 (figure 18) and the brass guide blocks 2 (figure 18).
	After cleaning the area under the rounding table (section 8.4.), also grease all the moving parts. Pay particular attention to the plastic slider 1 (figure 19) and the cross bearing 2 (figure 19).
	Check the tension of the V-belt, and tighten it if the rounding has started to slow down. Tighten the V-belt on the right side (outside) of the machine hand-tight using the hex pipe spanner.
	Check the oil level of the hydraulic system. The reservoir should be 3/4 full. A dipstick is fitted to the reservoir cap. The dipstick should have oil on it when removed.

Maintenance

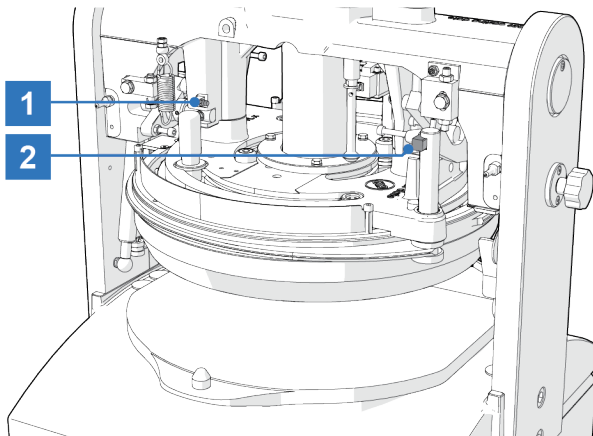

Figure 18 Greasing the console shafts and brass guide blocks

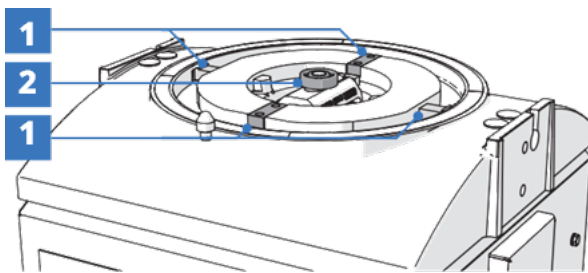

Figure 19 Greasing the plastic slider and cross bearing

NOTICE

- As lubricant, we recommend a PTFE EP-2 grease that conforms to the DIN 51502, ISO 6743, ISO-L-XCGHA2 and KFK2U-35 standards.
- As hydraulic oil we advise you good hydraulic oil as per DIN-51525, with viscosity as per ISO VG 32.
- Make sure that there are no dough rests between the rounding table and rounding plate, because this will cause damage to the dividing disc and rounding plate while working.

Cleaning the dividing knife and dividing disc

Required tools

- Brush
- Plastic scraper

Supplied tools

- Pipe spanner

Instructions

1. Remove front cover and back cover.
2. Pull the locking pin out.
3. Rotate the dividing disc towards you. Dividing disc will turn with the help of a gas spring.
4. Turn the power on.
5. Press and hold the two start buttons simultaneously until all forward movements complete. The display will show the following text: "CL ON".
6. Turn the power off.
7. Remove the pressing ring by turning it anticlockwise.
8. Clean the knife with a soft brush and plastic scraper.
9. Lubricate knife with oil base on paraffin.

Maintenance

NOTICE

Never use vegetable oil which will get hard.

10. Fit the pressing ring by turning it clockwise.
11. Turn the power on.
12. Press the two start buttons until the hydraulic unit shuts off and the knife is retracted.
13. Turn the power off.
14. Tilt the dividing disc downwards.
15. Push the locking pin back in.
16. Fit the front and rear cover.

Cleaning under the rounding table

Required tools

- Brush
- Damp cloth
- Plastic scraper
- Compressed air

Instructions

1. Remove the rounding table by firmly striking it on the underside.
2. Clean the area under the rounding table with a brush, damp cloth, plastic scraper or compressed air.
3. Re-grease the four recesses of the plastic slider and the bearing.
4. Place the rounding table back in position, and make sure the round opening is correctly pressed onto the bearing. Press the rounding table firmly in place, and check that it is laying straight.

NOTICE

The rounding table must lie flat.

Spare parts

Order spare parts from your dealer or the Moffat service department.

Have a qualified service technician install the spare parts. Otherwise, contact your dealer or the Moffat service department.

Troubleshooting

Troubleshooting

Problems, causes and solutions

Problem	Cause	Solution
The machine does not start.	The main switch is off.	Turn the power on.
	The emergency switch is on.	Unlock this if there is no danger
	The glass fuses have blown.	Replace the glass fuses. (*)
	The direction of rotation is wrong.	See section 6.4.
After rounding, the eccentric motion does not stop immediately.	The pressure of the hydraulic system is not between 35 and 50 bar.	<ol style="list-style-type: none"> 1. Top up the oil. 2. Check for leaks. 3. Adjust the screw setting on the proportional control board. 4. Optional with pressure control: Adjust the screw setting on the proportional control board.
	The tension springs are damaged, loose or broken.	Replace both tension springs.
The machine does not cut the dough.	The electrical/hydraulic parts of the hydraulic solenoid are not functioning properly.	Check the hydraulic valve, electrically and hydraulically. (*)
The machine does not round the dough.	The rounding time is not correct.	Adjust the rounding time.
	The thermal relay of the rounding motor produces a message on the display.	Press the blue button on the relay to reset it.
	The cross bearing does not push up the rounding cylinder.	Check the hydraulic valve, electrically and hydraulically. (*)
The dividing disc does not return.	The V-belt is not properly tensioned.	Increase the tension with the hex pipe spanner.
	The electrical/hydraulic parts of the hydraulic solenoid are not functioning properly.	Check the hydraulic valve, electrically and hydraulically. (*)
	The electrical/hydraulic parts of the hydraulic solenoid are not functioning properly.	Check the hydraulic valve, electrically and hydraulically. (*)

(*) If the problem is not solved, contact your dealer or the Moffat service department.

Troubleshooting

Error notifications

The following fault findings could appear in the display:

Fault message	Cause	Solution
E1 (switch cover)	The front or back cover is loose during operation.	Attach the front and rear cover.
	The back cover switch is malfunctioning.	Replace the switch for the cover. (*)
E2 (switch pressing ring)	The end switch of the press ring is malfunctioning.	Replace the limit switch for the ring. (*)
	The pressing ring is not fitted.	Fit the pressing ring.
	The pressing ring is dirty and does not contact the limit switch in time.	Clean the pressing ring. (*)
E3 (switch volume bar)	The end switch of the volume bar is malfunctioning.	Turn the volume bar to the correct setting depending on the dough weight.
	The end switch of the volume bar is mispositioned to the volume bar.	<ol style="list-style-type: none">1. Replace the limit switch.2. Check the wiring.
E4 (thermal overload is activated)	The hydraulic motor and rounding motor have stopped.	Reset the relay by pressing the blue button of the corresponding relay in the control cabinet.
E5 (emergency button is pressed)	The emergency switch is on.	Unlock this if there is no danger
E6 (1 or 2 start buttons are defective)	The start buttons aren't touched simultaneously within 0,5 seconds.	Press the two start buttons simultaneously.

Taking out of operation

Taking out of operation

Disconnecting the machine

1. Switch off the machine by turning the main switch to "0".
2. Disconnect the power supply cable.

Disposal

Disposal

Disposing of the machine

When carrying off a complete machine, parts or only the packing, you should comply with the legal regulations. Specifications concerning the material of the parts can be asked for at the manufacturers.

