

Service manual

Cutting table

SFT262

SFT362

SFT262V

SFT362V

SFT262DD

SFT262DDV

Edition SD516102

04.2015

Technical specifications subject to change without notice

RONDO Burgdorf AG

Heimswilstrasse 42
3400 Burgdorf / Switzerland
Tel. +41 34 420 81 11
Fax +41 34 420 81 99
info@rondo-online.com
www.rondo-online.com

RONDO Schio s.r.l.

Via Lago di Albano, 86
36015 Schio (VI) / Italy
Tel. +39 0445 575 429
Fax +39 0445 575 317
info.it@rondo-online.com

RONDO GmbH & Co. KG

Hoorwaldstrasse 44
57299 Burbach / Germany
Tel. +49 2736 203-0
Fax +49 2736 203130
info.de@rondo-online.com

RONDO S.à.r.l.

PAE „Les Pins “
67319 Wasselonne Cédex / France
Tel. +33 3 88 59 11 88
Fax +33 3 88 59 11 77
info.fr@rondo-online.com

RONDO Ltd.

Unit 7, Chessington Park
Lion Park Avenue
Chessington, Surrey KT9 1ST / UK
Tel. +44 20 8391 1377
Fax +44 20 8391 5878
info.uk@rondo-online.com

RONDO Inc.

100 State Street
Moonachie, N.J. 07074 / USA
Tel. +1 201 229 97 00
Fax +1 201 229 98 78
info.us@rondo-online.com

OOO RONDO Rus

Dmitrovskoye Chaussee, 163A, b. 2
Office 18.5 / Business Center SK Plaza
127495 Moscow / Russia
Tel. +7 (495) 419 51 23
Fax +7 (495) 419 51 25
info.ru@rondo-online.com

RONDO Asia Sdn. Bhd.

A-2-21, Jalan Kuchai Maju 2
Kuchai Entrepreneurs Park
58200 Kuala Lumpur / Malaysia
Tel: +60 3 7984 55 20
Tel: +60 3 7984 55 30
Fax: +60 3 7984 55 95
info.my@rondo-online.com

RONDO China

Room 2830, Guangzhou International
Gang Hang Center
No. 983 Huangpu Avenue East.
Huangpu District
Guangzhou City P.C 510700
Guangdong Province
Tel. +86 20 8388 2211
Fax +86 20 8388 8601
info.cn@rondo-online.com

RONDO Iberia

C/ Camelia 75, 1D-4B
29630 Benalmádena-Costa, Malaga / Spain
Tel. +34 952 961 043
info.es@rondo-online.com

RONDO México

Ote. 180 No. 378
Col. Moctezuma
2da sección
C.P. 15530 México D.F. / Mexico
Tel. +52 55 2580 7075
info.mx@rondo-online.com

1 Safety regulations

2 Full view of the cutting table

3 Recommended spare parts

3.1 Mechanical spare parts

3.2 Electrical spare parts

4 Part names, drawings

4.1 Cutting tables

4.1.1 Cutting table SFT262

4.1.2 Cutting table SFT362

4.2 Cutting station

4.2.1 Adjusting of spring range ZSS601

4.3 Drive SFT

4.4 Electrical control box

4.4.1 Electrical control box SFT*62; EU/USA

4.4.2 Electrical control box SFT*62; var; EU/USA

5 Electro circuit diagram

1 Sicherheitsvorschriften / Prescriptions de sécurité / Safety regulations

Unbedingt zu beachtende Sicherheitsvorschriften und -hinweise

Bei allen Reparatur-, Instandhaltungs-, Reinigungs- und ähnlichen Arbeiten an Maschinen ist vor Beginn der Arbeiten die Zuführung sämtlicher Energiequellen zu dieser zu unterbrechen. D.h. die Netzstecker bei den Anlagen, Ausrollmaschinen, etc. bzw. die Gerätestecker bei den Zusatzgeräten sind herauszuziehen.

Ebenso sind alle eventuell vorhandenen Druckluftzuleitungen zu unterbrechen und zu entlüften!

Weiter sind sämtliche Sicherheitsvorschriften und -hinweise, gemäss Betriebsanleitung Kapitel 1, zu beachten!

Prescriptions et conseils de sécurité à observer obligatoirement

Avant tous travaux de réparation, d'entretien, de nettoyage et similaires, effectués sur les machines, il faut déconnecter l'alimentation de toutes les sources d'énergie. Cela signifie de débrancher les fiches de contact sur les installations, les laminoirs etc. respectivement les fiches d'appareil sur les accessoires.

Il faut également couper et purger toutes les conduites d'air comprimé, éventuellement existantes!

De plus, il faut observer toutes les prescriptions et conseils de sécurité selon chapitre 1 du mode d'emploi!

Safety instructions and information which must be followed

The power supply to the machine must be interrupted before beginning any repair, maintenance, cleaning or similar work on the machines. This means that the mains plugs of the installations, sheeters, etc. respectively the appliance plugs of the accessories must be disconnected.

Likewise, any existing compressed air supply lines must be disconnected and vented!

In addition, follow all safety instructions and information according to chapter 1 of the operating manual!

2 Full view of the cutting table

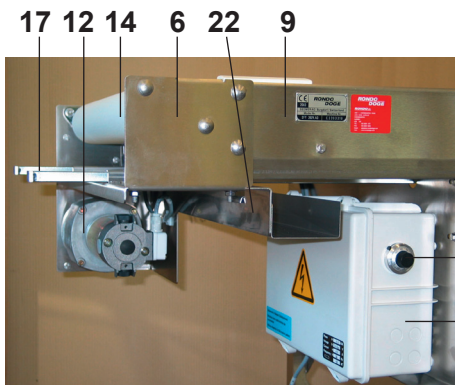
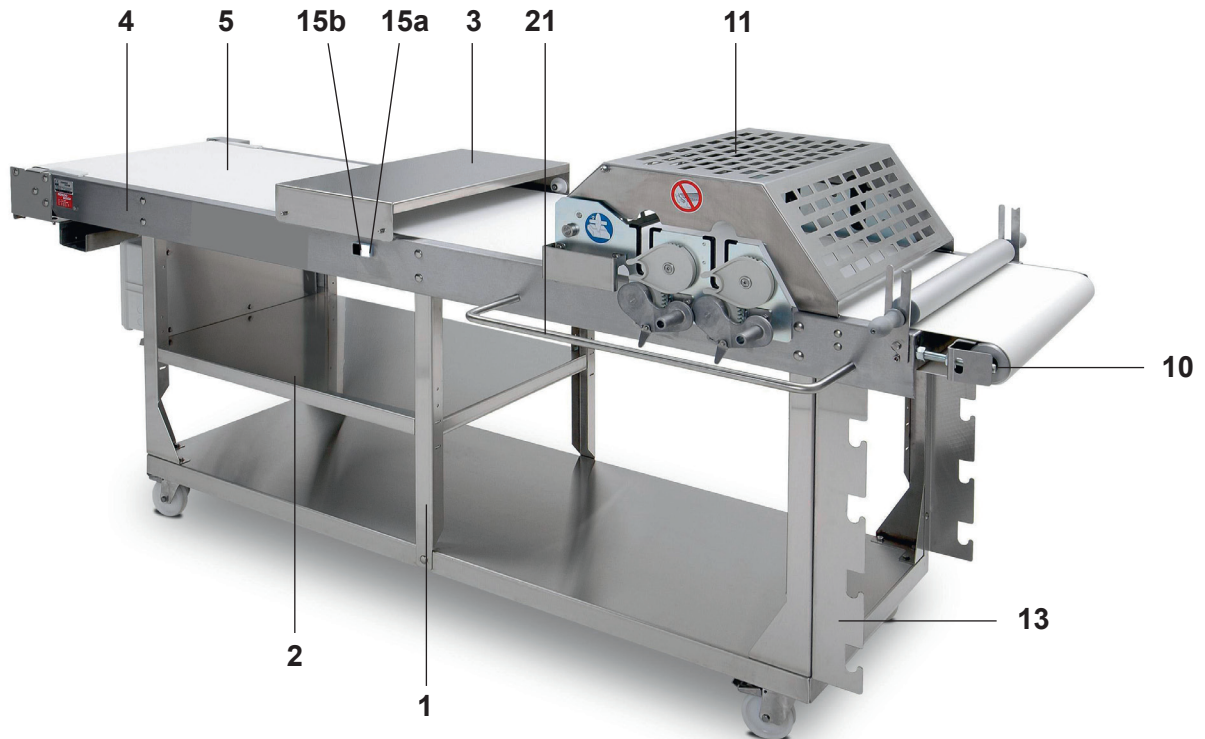

- 1 Machine base
- 2 Tray
- 3 Movable tray
- 4 Table sheet
- 5 Conveyor belt
- 6 Drive unit
- 7 Cutting station
- 8 Dough reeler bracket
- 9 Scraper
- 10 Idle roller
- 11 Safety guard
- 12 Motor
- 13 Cutter bracket
- 14 Drive roller
- 15a "Start" push-button
- 15b "Stop" push-button
- 16 Potentiometer (only for variable speeds)
- 17 Support bars for baking trays (extendible)
- 18 Tension lever
- 19 Stop lever
- 20 Electrical box
- 21 Safety rail
- 22 Flour container

3 Empfohlene Ersatzteile Pièces de rechange recommandées Recommended spare parts

3.1 Mechanische Ersatzteile / Pièces de rechange mécaniques / Mechanical spare parts

Bestell-Nr. No commande Ordering no	Teilebezeichnung Désignation Part name		
8934	Feinsicherung 1,0 A träg	Fusible 1,0 A lent	Fuse 1,0 A slow
8935	Feinsicherung 2,0 A träg	Fusible 2,0 A lent	Fuse 2,0 A slow
11053	Feinsicherung 6,3 A träg	Fusible 6,3 A lent	Fuse 6,3 A slow
11432	Feinsicherung 6,3 A superflink	Fusible 6,3 A ultra rapide	Fuse 6,3 A super-quickacting
50372	Zahnriemen 600-5MR-15	Courroie dentée 600-5MR-15	Toothed belt 600-5MR-15
50659	Gasfeder 200 N	Ressort pneumatique 200 N	Gas spring 200 N
103898	Abstreifer	Racleur	Scraper
103898T03	Abstreifer	Racleur	Scraper
106512	Transportband 640 x 5330	Tapis de transport 640 x 5330	Conveyor belt 640 x 5330
106513	Transportband 640 x 7210	Tapis de transport 640 x 7210	Conveyor belt 640 x 7210
121334T02	Torsionsfeder	Ressort à torsion	Torsion spring
122774T08	Abstreiferhalter	Support pour lame de racleur	Scraper blade support
122955T03	Abstreifermesser oben	Lame de racleur en haut	Scraper blade above
123527	Zahnriemenrad Z=40	Roue courroie dentée Z=40	Wheel toothed belt Z=40
123528	Zahnriemenrad Z=26	Roue courroie dentée Z=26	Wheel toothed belt Z=26
125463	Zahnsegment	Segment denté	Toothed quadrant

**3.2 Elektrische Ersatzteile /
Pièces de rechange électriques /
Electrical spare parts**

Siehe Gerätstückliste im Elektroschema!

Voir liste des pièces d'appareil dans le schéma électrique!

See appliance parts list in the electro circuit diagram!

4 Teilebezeichnungen, Zeichnungen Désignations des pièces, dessins Part names, drawings

4.1 Schneidetische Tables de découpe Cutting tables

4.1.1 Schneidetisch SFT262 Table de découpe SFT262 Cutting table SFT262

123540

Bestell-Nr. No commande Ordering no	Teilebezeichnung Désignation Part name		
9832	Lenkrolle 100 x 128	Roulette pivotante 100 x 128	Guide roll 100 x 128
11527	Plattenlenkrolle mit Bremse	Roulette pivotante plaque avec frein	Guide roll plate with brake
51200	Hilfsschalterblock	Bloc de interrupteur auxiliaire	Auxiliary switch block
51204	Hilfsschalter	Interrupteur auxiliaire	Auxiliary switch
51362	Taster mit Schutzkappe	Bouton avec capot de protection	Button with protective cap
89231	Führung	Guidage	Guidance
92206	Haspelhalter	Support enrouleur	Dough reeler bracket
104448	Abdeckhaube	Couvercle de fermeture	Cover hood
106510T02	Leerlaufrolle komplett	Rouleau à vide complet	Idle roller complete
106512	Transportband 640 x 5330 mm	Tapis de transport 640 x 5330 mm	Conveyor belt 640 x 5330 mm
121194	Bandführung blau	Guidage de tapis bleu	Conveyor belt guide blue
122774T08	Abstreiferhalter	Support de racleur	Scraper support
122955T03	Abstreifermesser	Lame de racleur	Scraper blade
123371	Fingerschutz	Protège-doigts	Finger guard
123537	Teleskopauszug	Glissière télescopique	Telescopic slide-out
123544	Kabelschutz	Protection de câble	Cable protection
126486	Mehlbehälter	Bac à farine	Flour container
130689	Tischblech komplett SFT262	Tôle de la table complète SFT262	Table sheet complete SFT262
200449	Rollenhalter	Support du rouleau	Roller bracket

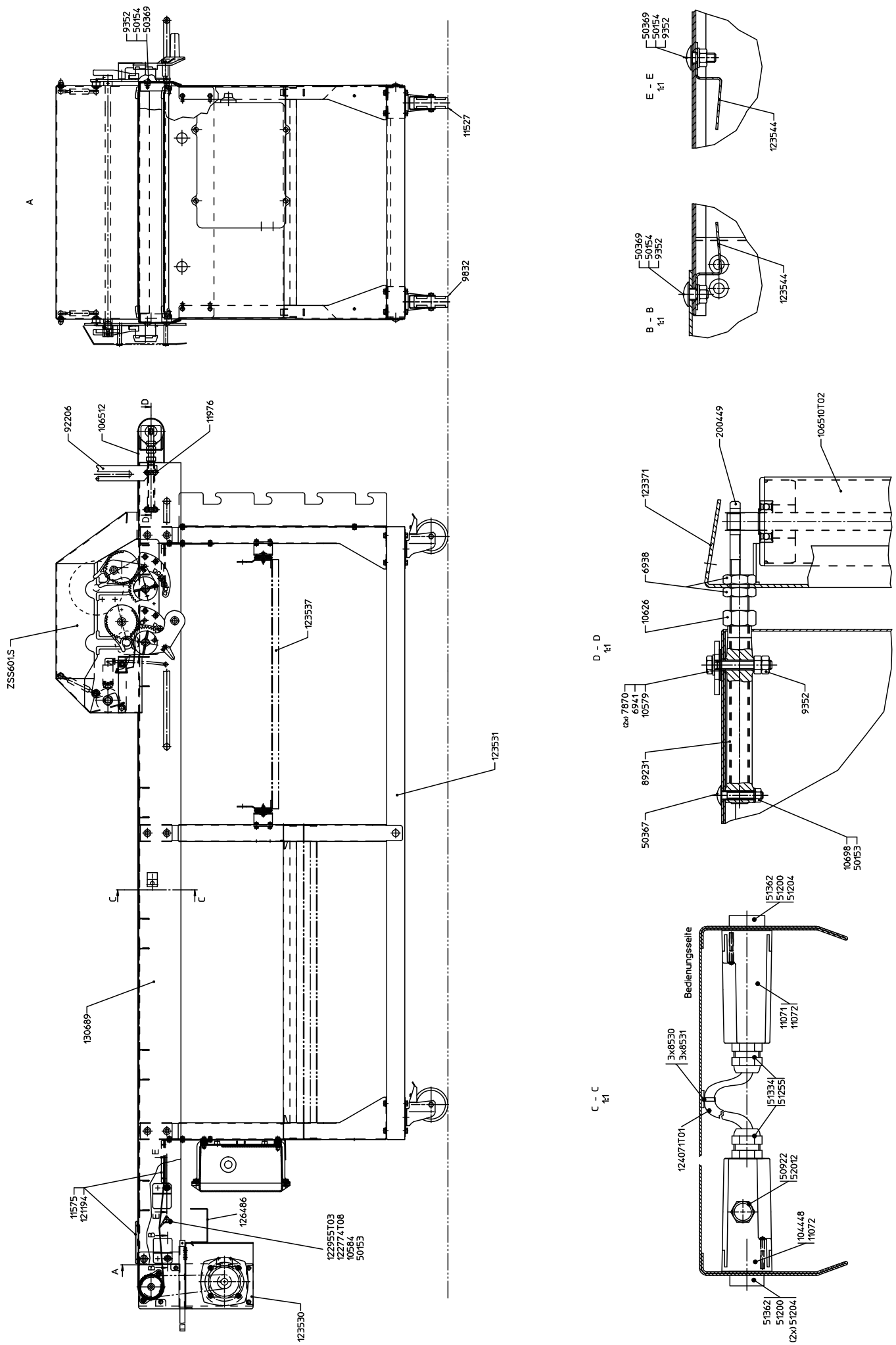

4.1.1

Schneidetisch SFT262
 Table de découpe SFT262
 Cutting table SFT262

1/1
20.12.17 PeD
123540 j

4.1.2 Schneidetisch SFT362
Table de découpe SFT362
Cutting table SFT362

123510

Bestell-Nr. No commande Ordering no	Teilebezeichnung Désignation Part name		
9832	Lenkrolle 100 x 128	Roulette pivotante 100 x 128	Guide roll 100 x 128
11527	Plattenlenkrolle mit Bremse	Roulette pivotante plaque avec frein	Guide roll plate with brake
51200	Hilfsschalterblock	Bloc de interrupteur auxiliaire	Auxiliary switch block
51204	Hilfsschalter	Interrupteur auxiliaire	Auxiliary switch
51362	Taster mit Schutzkappe	Bouton avec capot de protection	Button with protective cap
89231	Führung	Guidage	Guidance
92206	Haspelhalter	Support enrouleur	Dough reeler bracket
104448	Abdeckhaube	Couvercle de fermeture	Cover hood
106510T02	Leerlaufrolle komplett	Rouleau à vide complet	Idle roller complete
106513	Transportband 640 x 7210 mm	Tapis de transport 640 x 7210 mm	Conveyor belt 640 x 7210 mm
121194	Bandführung blau	Guidage de tapis bleu	Conveyor belt guide blue
122774T08	Abstreiferhalter	Support de racleur	Scraper support
122955T03	Abstreifermesser	Lame de racleur	Scraper blade
123371	Fingerschutz	Protège-doigts	Finger guard
123537	Teleskopauszug	Glissière télescopique	Telescopic slide-out
123544	Kabelschutz	Protection de câble	Cable protection
126486	Mehlbehälter	Bac à farine	Flour container
130691	Tischblech komplett SFT362	Tôle de la table complète SFT362	Table sheet complete SFT362
130693	Tischblech komplett 362 Schneidstation	Tôle de la table complète 362 station de découpe	Table sheet complete 362 Cutting station
200449	Rollenhalter	Support du rouleau	Roller bracket

4.2 Schneidestation
Station de découpe
Cutting station

128335 / 128708

Bestell-Nr. No commande Ordering no	Teilebezeichnung Désignation Part name		
6682	Gewindestift M6 x 8	Vis sans tête M6 x 8	Set screw M6 x 8
6684	Gewindestift M6 x 10	Vis sans tête M6 x 10	Set screw M6 x 10
7246	Rillenkugellager 6201 2RS	Roulement à billes 6201 2RS	Ball bearing 6201 2RS
10712	Sicherungsring für Welle 12 x 1	Circlip pour arbre 12 x 1	Locking ring for shaft 12 x 1
11571	Distanzbolzen M6 x 55	Bouton d'écartement M6 x 55	Distance bolt M6 x 55
11965	Grenztaster	Commutateur de fin de course	Limit switch
50093	Stelling	Bague d'arrêt	Adjusting ring
50277	Passkerbstift 5 x 60	Goupille cannelée d'ajustage 5 x 60	Half length taper-grooved dowel pin 5 x 60
50428	Spannstift 5 x 24	Goupille de serrage 5 x 24	Dowel pin 5 x 24
50659	Gasfeder 200 N	Ressort pneumatique 200 N	Gas spring 200 N
83273T05	Rolle	Rouleau	Roller
100979	Schaltrad	Roue de commande	Ratchet wheel
101507	Führung	Guidage	Guidance
103898	Abstreifer	Racleur	Scraper
103898T03	Abstreifer	Racleur	Scraper
120219	Niederhalter	Serre-flan	Blank holder
121332	Mitnehmer	Entraîneur	Catch
121334T01	Torsionsfeder	Ressort à torsion	Torsion spring
121334T02	Torsionsfeder	Ressort à torsion	Torsion spring
121337	Rastsegment	Segment cranté	Catch segment
121339	Hülse	Douille	Bush
121340T02	Welle	Arbre	Shaft
123317	Strebe für Schneidestation	Contre-fiche p. station découpe	Stanchion for cutting station
124632	Schutzbügel	Poignée	Guard tube
126492T01	Rohr	Tube	Tube
127348	Halteplatte rechts	Platine droite	Holding plate right
127349	Halteplatte links	Platine gauche	Holding plate left
127556	Schutz	Protection	Protection
127599	Schutzblech	Tôle de protection	Protection sheet
127600	Schutzhaube komplett	Capot de protection	Protection cap
128109	Federführung mit Lager	Guidage de ressort avec palier	Spring guide with bearing
128332	Hebel komplett	Levier complet	Lever complete
128704	Halteplatte vorne links nach rechts	Platine antérieure gauche vers droit	Anterior holding plate left towards right
128705	Halteplatte hinten links nach rechts	Platine postérieure gauche vers droit	Posterior holding plate left towards right
129512	Hebel komplett links	Levier gauche complet	Lever left complete
129589	Schutzblech links nach rechts	Tôle de protection gauche vers droite	Protection plate left towards right
131036	Schaltstab	Barre de commande	Selector rod
158328V1	Drehherz komplett	Toc du tour complet	Driving dog complete
158329V1	Zahnsegment komplett	Segment denté complet	Toothed quadrant complete

4.2

Schneidstation Ansicht vorne ZSS601.A/B/S Station de découpe vue d'avant ZSS601.A/B/S Cutting station front view ZSS601.A/B/S

1/1
20.12.17 PeD
128335 g

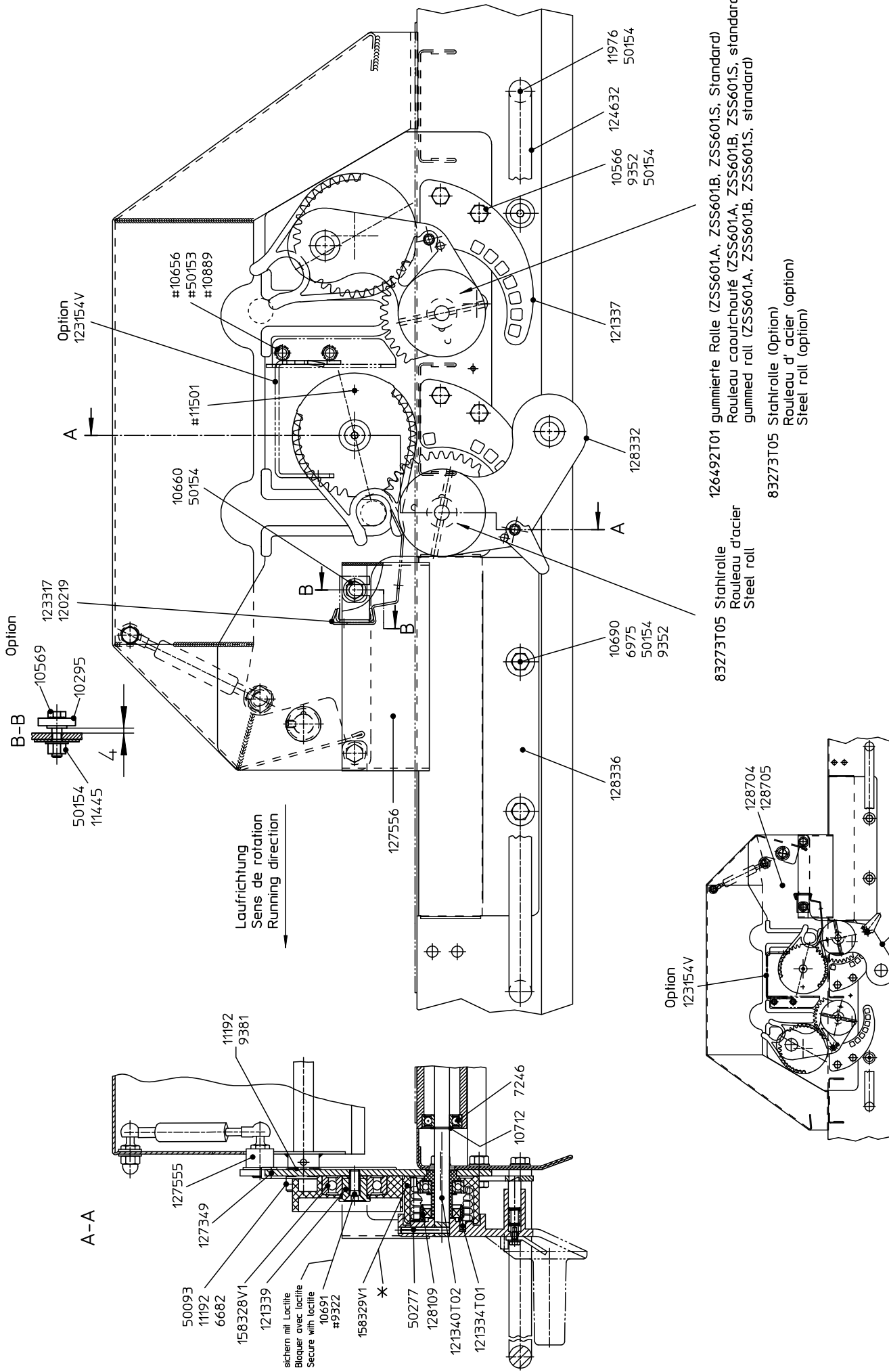

Pendant le montage monter la fin du ressort dans le trou, le deuxième plus massif !
Exceptions: SFT262 modèles Etats-Unis, SFT26200 tous les modèles, montez-le dans le trou, le plus massif !

For assembly put the end of the spring in the second-strong hole !
Exceptions: SFT262 USA versions, SFT26200 all versions, put in the strongest hole !

126492T01 gummierter Rolle (ZSS601.A, ZSS601.B, ZSS601.S, Standard)
Rouleau caoutchouc (ZSS601.A, ZSS601.B, ZSS601.S, standard)
gummed roll (ZSS601.A, ZSS601.B, ZSS601.S, standard)

83273T05 Stahlrolle (Option)
Rouleau d'acier (option)
Steel roll (option)

83273T05 Stahlrolle
Rouleau d'acier
Steel roll

*

Ausführung links nach rechts
Type gauche à droite
Type left to right

nur für SFT USA-Ausführung
seulement pour SFT modèle Etats-Unis
only for SFT USA-version

4.2

Schneidestation Ansicht hinten ZSS601.A/B/S
 Station de découpe vue d'arrière ZSS601.A/B/S
 Cutting station rear view ZSS601.A/B/S

1/1
 15.04.15 WaL
 128708 f

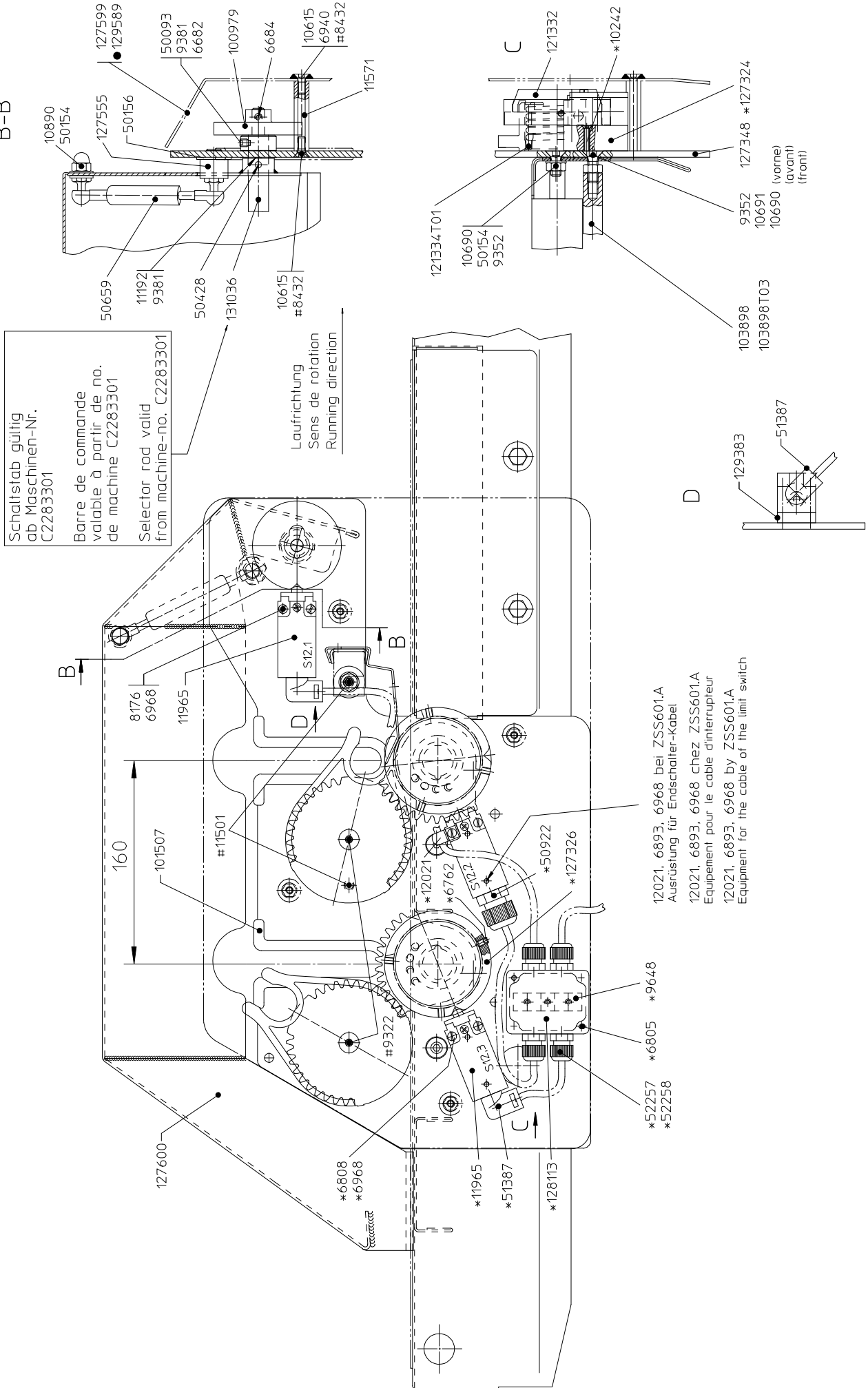

Vorderseite (Bedienungsseite)
 frontside
 côté avant

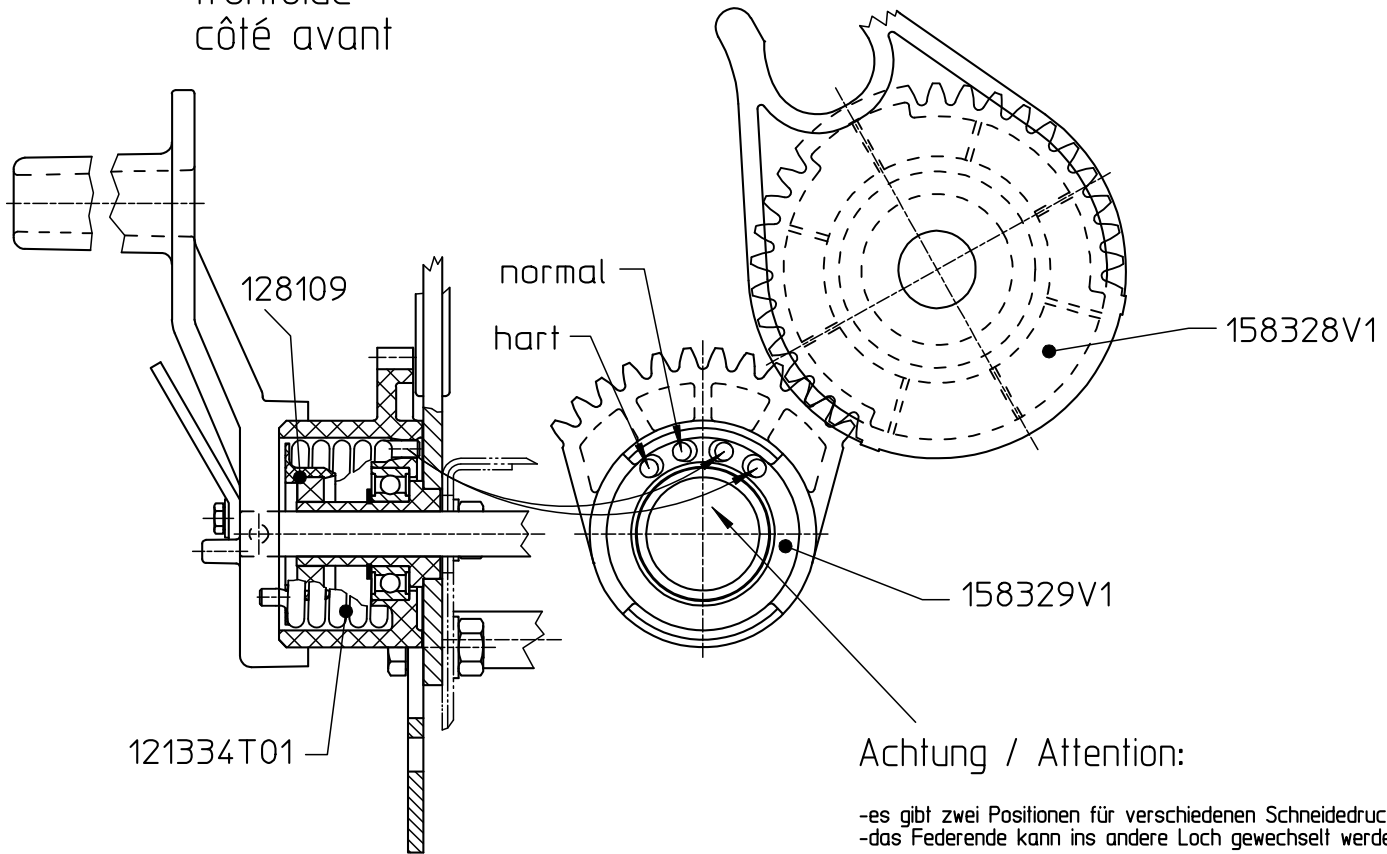

Achtung / Attention:

- es gibt zwei Positionen für verschiedenen Schneidedruck. (normal / hart)
- das Federende kann ins andere Loch gewechselt werden.
- there are two position to have different cutting pressure. (normal / hard)
- change the end of the spring in the other hole.
- il y a deux positions pour pression de coupe différents. (normale / dur)
- la fin du ressort peut être changer dans l'autre trou.

Rückseite
 backside
 côté arrière

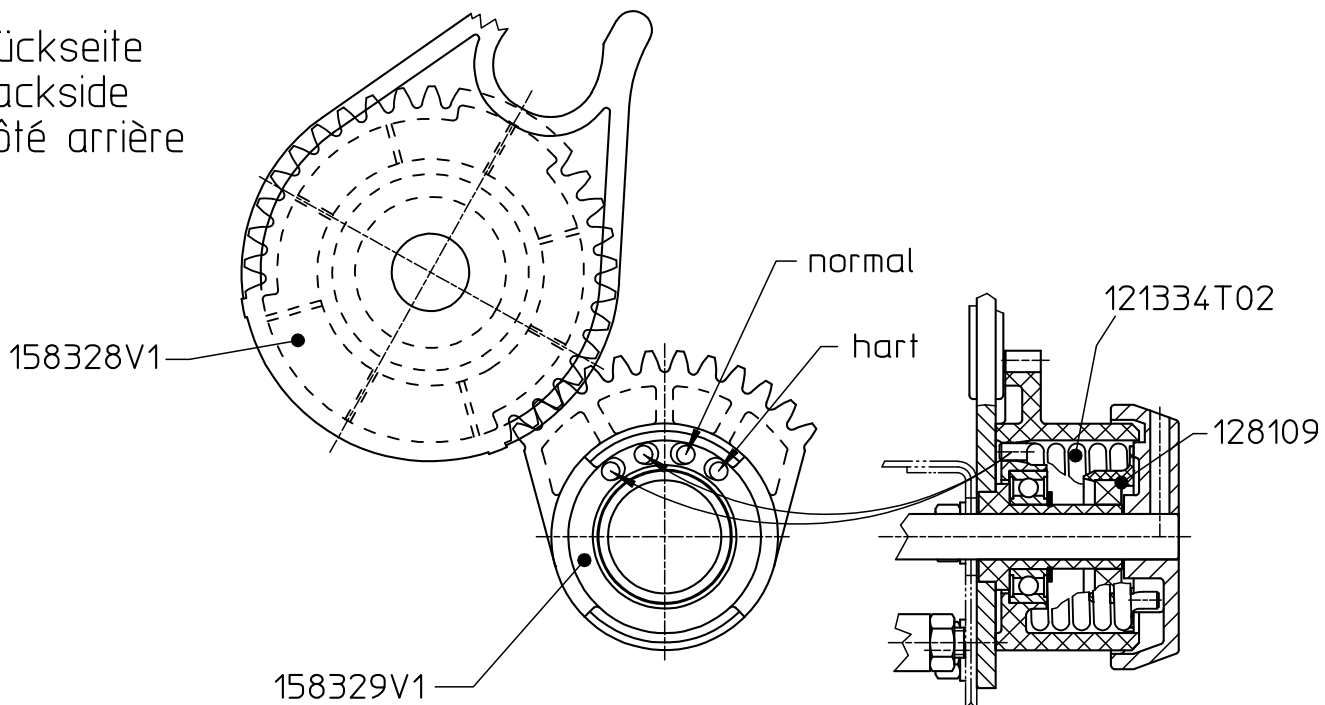

4.2.1

Federbereich einstellen ZSS601
 Ajuster la zone du ressort ZSS601
 Adjusting of spring range ZSS601

1/1
26.10.15 ScYv
129152 c

**4.3 Antrieb SFT
Entraînement SFT
Drive SFT**

123530

Bestell-Nr. No commande Ordering no	Teilebezeichnung Désignation Part name		
7034	Spannstift 6 x 40	Goupille de serrage 6 x 40	Dowel pin 6 x 40
7041	Spannstift 4 x 20	Goupille de serrage 4 x 20	Dowel pin 4 x 20
7550	Kabeldurchföhrtdülle	Profilé de protection de cable	Cable grommet
8780	Flanschlager 20 / M10	Coussinet à bride 20 / M10	Flange bearing 20 / M10
9105	Spannstift 6 x 70	Goupille de serrage 6 x 70	Dowel pin 6 x 70
50348	Getriebemotor 180 W	Moteur réducteur 180 W	Gear-motor 180 W
50372	Zahnriemen	Courroie dentée	Toothed belt
50374	3AC-Getriebemotor 90 W / 230-400 V / 50 Hz	3AC-Moteur réducteur 90 W / 230-400 V / 50 Hz	3AC-Gear-Motor 90 W / 230-400 V / 50 Hz
50375	3AC-Getriebemotor 90 W / 230-400 V / 60 Hz	3AC-Moteur réducteur 90 W / 230-400 V / 60 Hz	3AC-Gear-Motor 90 W / 230-400 V / 60 Hz
103490T04	Achse	Axe	Axle
105406	Deckel	Couvercle	Cover
105407(UL)	Deckel UL	Couvercle UL	Cover UL
106971	Antriebsrolle	Rouleau d'entraînement	Drive roller
123527	Zahnriemenrad Z=40	Roue courroie dentée Z=40	Toothed belt wheel Z=40
123528	Zahnriemenrad Z=26	Roue courroie dentée Z=26	Toothed belt wheel Z=26
126836	Getriebekasten komplett	Boîte d'engrenages complète	Gear box complete
132222	Elektrokasten	Boîtier électrique	Electrical box
132224	Elektrokasten	Boîtier électrique	Electrical box
200491	Ausziehstab	Barre	Bar

4.3

Antrieb SFT
 Entraînement SFT
 Drive SFT

1/1
 27.09.17 FuT
 123530 h

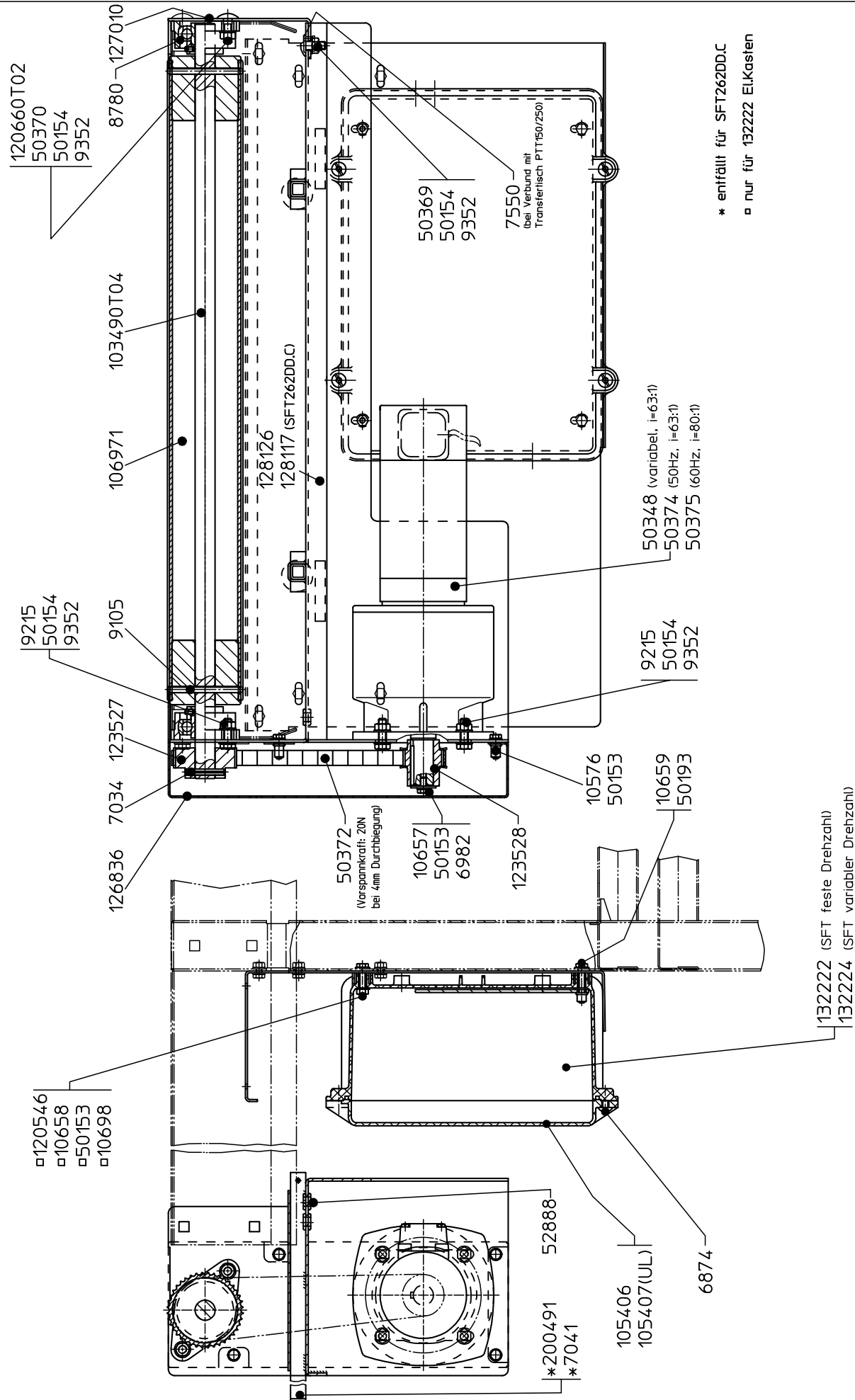

* entfällt für SFT262DD.C
 □ nur für 132222 El.Kasten

4.4 Elektrokasten
Boîte électrique
Electrical control box

4.4.1 Elektrokasten SFT*62; EU/USA
Boîte électrique SFT*62; EU/USA
Electrical control box SFT*62; EU/USA

132222

Bestell-Nr. No commande Ordering no	Teilebezeichnung Désignation Part name		
8934	Feinsicherung	Fusible fin	Fine fuse
11053	Feinsicherung	Fusible fin	Fine fuse
50000	Einphasen Trenntransformator	Transformateur d'isolement monophasé	Isolating transformer single phase
52120	Durchgangsklemme	Borne	Terminal
52122	Schutzleiterklemme	Borne ferre	Earth lead terminal
52124	Abschlussplatte	Plaque de fermeture	End cover plate
52127	Sicherungsklemme ohne LED	Borne de sécurite sans DEL	Terminal fuse without LED
52128	Sicherungsklemme mit LED	Borne de sécurite avec DEL	Terminal fuse with LED
52131	Endklammer	Clip final	End clamp
53436	Kleinleistungsschutz	Contacteur de petite puissance	Main contactor miniature

4.4.1

El. Kasten SFT*62, EU/USA
 Boîte électrique SFT*62, EU/USA
 Electrical control box SFT*62, EU/USA

1/1
 15.04.15 WaL
 132222 a

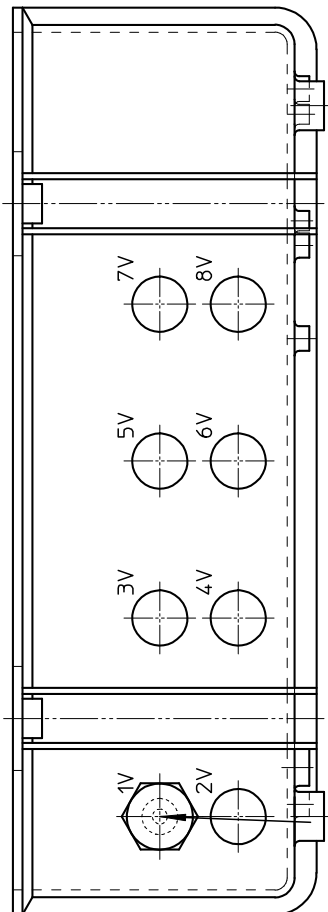
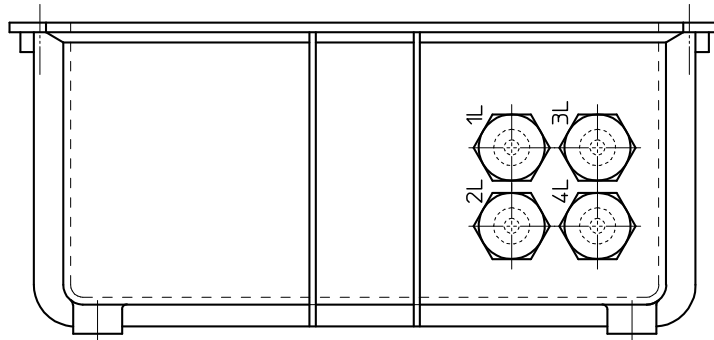
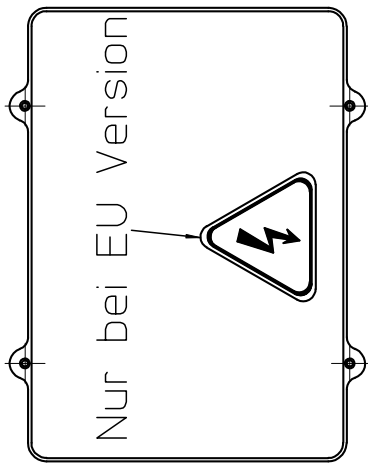

Kabel innen mit Kabelbinder sichern!!
 (Zugentlastung)

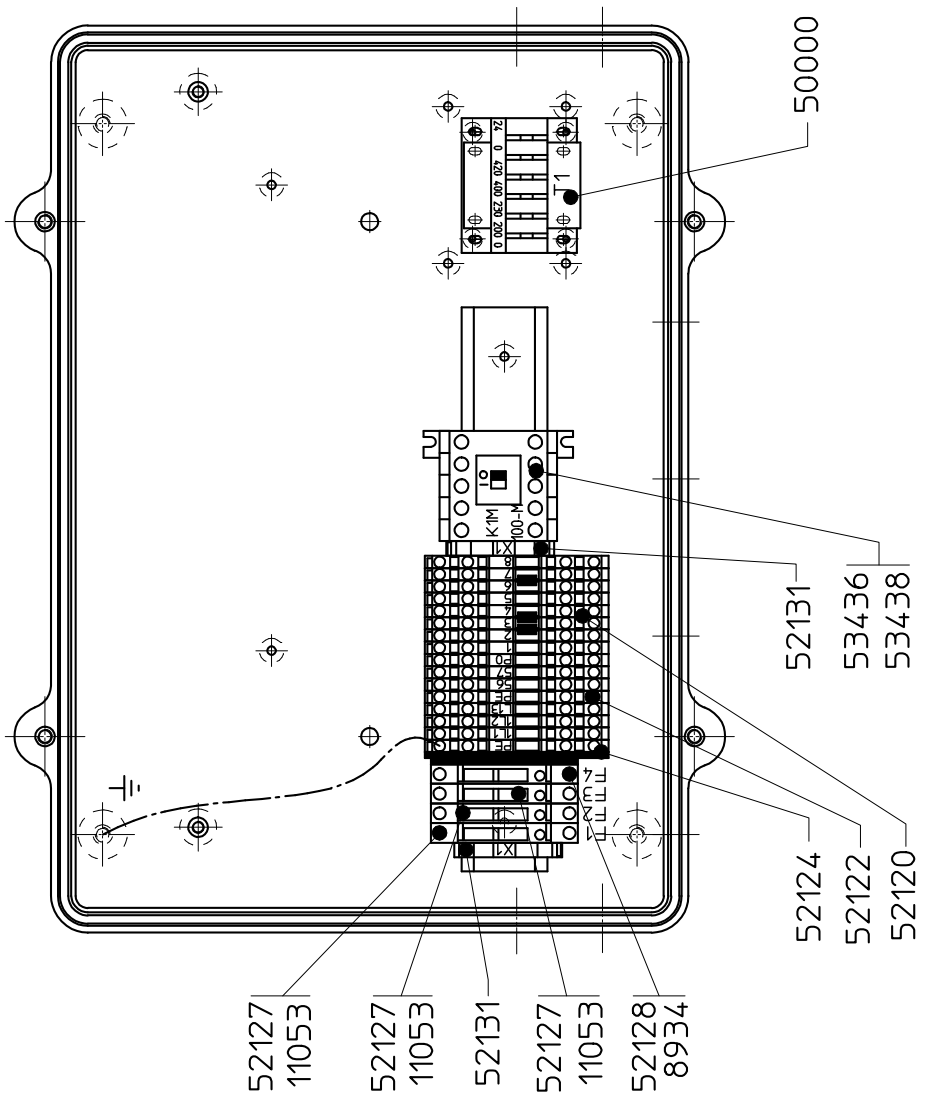

4.4.2 Elektrokasten SFT*62; var; EU/USA
Boîte électrique SFT*62; var; EU/USA
Electrical control box SFT*62; var; EU/USA

132224

Bestell-Nr. No commande Ordering no	Teilebezeichnung Désignation Part name		
8935	Feinsicherung 2,0 A trög	Fusible fin 2,0 A lent	Fine fuse 2,0 A slow
11053	Feinsicherung 6,3 A trög	Fusible fin 6,3 A lent	Fine fuse 6,3 A slow
11432	Feinsicherung 6,3 A Superflink 5 x 20	Fusible fin 6,3 A ultra rapide 5 x 20	Fine fuse 6,3 A Super-quickacting 5 x 20
11745	Drehzahlregler	Régulateur de vitesse	Speed regulator
50040	Einphasen Trenntransformator	Transformateur d'isolement monophasé	Isolating transformer single phase
50434	Einphasen Netzfilter	Filtre d'alimentation monophasé	Mains filter single phase
51373	Potentiometer	Potentiomètre	Potentiometer
52120	Durchgangsklemme	Borne	Terminal
52122	Schutzleiterklemme	Borne ferre	Earth lead terminal
52124	Abschlussplatte	Plaque de fermeture	End cover plate
52127	Sicherungsklemme ohne LED	Borne de sécurite sans DEL	Terminal fuse without LED
52128	Sicherungsklemme mit LED	Borne de sécurite avec DEL	Terminal fuse with LED
52131	Endklammer	Clip final	End clamp
53436	Kleinleistungsschutz	Contacteur de petite puissance	Main contactor miniature
54403	Potentiometerknopf	Bouton à potentiomètre	Potentiometer button

5 Electro circuit diagram



RONDO Burgdorf AG
 Heimiswilstrasse 42
 CH-3400 Burgdorf
 Tel.: +41 34 420 81 11
 Fax: +41 34 420 81 99
 Website: www.rondo-online.com
 E-mail: service@ch.rondo-online.com

Maschine	Machine	Machine	:Schneidetisch v=fix
Modelnummer	Model number	Numéro de model	:SFT*62*
Schema Nr.	Drawing number	Numéro de dessin	:505134
Auftragsnummer	Commission number	Numéro de commande	:
Maschinennummer	Machine number	Numéro de machine	:
Manufacturer (company)	RONDO Burgdorf AG CH-3400 Burgdorf		
Company / customer City			
Project path	L:\Electric P8\EPLAN_DATA\Projekte\RDB\5051xx\505134.elk		
Project path .PDF	G:\PROJEKTE\PDF\PDF_Schema SMB		
Responsible for project	HU.Ryser		
Created on	01.11.2012		
Edit date	13.01.2014	by (short name) Ryser_h	Number of pages 14

Drahtfarben - Wire colours - Coueurs de fil -

Wechselspannung - AC voltage - Tension alternative -

Phase	L1	Phase	L1	Phase	L1	schwarz - black - noir -
Phase	L2	Phase	L2	Phase	L2	schwarz - black - noir -
Phase	L3	Phase	L3	Phase	L3	schwarz - black - noir -
Neutralleiter	N	neutral conductor	N	conducteur neutre	N	hellblau - light blue - bleu clair -
Schutzleiter	PE	protective wire	PE	conducteur de protection	PE	gelb/grün - yellow/green - jaune/vert -
Steuerspannung vor Transformator	L	Control voltage before transformer	L	Tension de comm. avant tranformateur	L	schwarz - black - noir -
Neutralleiter vor Transformator	N	Neutral conductor before transormator	N	Conducteur neutre avant transformateur	N	hellblau - light blue - bleu clair -
Steuerspannung nach Transformator	**VAC	Control voltage after transformer	**VAC	Tension de commande apès transformateur	**VAC	rot - red - rouge -
Neutralleiter nach Transformator	0VAC	Neutral conductor after transformer	0VAC	Conducteur neutre avant transformateur	0VAC	rot/weiss - red/white - rouge/blanc -
Steuerspannung geschaltet	**VAC	Control voltage switched	**VAC	Tension de commande branché	**VAC	lila - purple - lilas -

Gleichspannung - DC voltage - Tension continue -

Hauptstromkreise	L+	Main circuits	L+	Cuircuit prinzipaux	L+	schwarz - black - noir -
Hauptstromkreise	L-	Main circuits	L-	Cuircuit prinzipaux	L-	schwarz - black - noir -
Steuerstromkreise	+VDC	Control circuits	+VDC	Cuircuit de commande	+VDC	blau - blue - bleu -
Steuerstromkreise	0VDC	Control circuits	0VDC	Cuircuit de commande	0VDC	blau/weiss - blue/white - bleu/blanc -
Steuerstromkreise geschaltet	**VDC	Control circuits switched	**VDC	Cuircuit de commande branché	**VDC	violett - violet - violet -

Analogsignale - Analog signals - Signaux analogiques -

Sollwert/Istwert	+	Set value/Actual value	+	Valeur théoretique/effective	+	grau - grey - gris -
Regelerde	-	Control ground	-	Terre de régulation	-	weiss - white - blanc -

Fremdspannung - External voltage - Tension d'origine étrangères -

Steuerstromkreise extern	VAC/DC	Control circuits external	VAC/DC	Cuircuit de commande externe	VAC/DC	orange - orange - orange -
--------------------------	--------	---------------------------	--------	------------------------------	--------	----------------------------

Strukturkennzeichenübersicht / Structure identifier overview / Aperçu des identificateurs de structure /

Funktionale Zuordnung Functional assignment Attribution fonctionnelle	Beschreibung Description Description
==GEN	Allgemein General Général
==S1	Sektion 1 Section 1 Section 1
==DATA	Daten data données

+COMPONENT	Artikel item article
+CABLE	Kabel Cable Cables

Anlage Installation Installation	Beschreibung Description Description
=01	Schneidetisch v=fix Cutting table v=fix Table de decoupe v=fix
=DOC	Dokumentation documentation Documentation

Einbauort Mounting location Lieu de montage	Beschreibung Description Description
+MAIN	Hauptverzeichnis Main directory Dossier principal
+PAG	Inhaltsverzeichnis Table of contents Sommaire
+1	auf Steuerplatte on control plate sur plaque de commande
+Ma	an Maschine on machine sur machine
+TERMINAL	Klemmen Terminals Bornes
+CONNECTOR	Stecker Plug Connecteur

Inhaltsverzeichnis - Table of contents - Sommaire -

Functional assignment	Higher-level function	Mounting location	Page	Page description	Modification		
					Index	Modification number	Modification date
==GEN	=DOC	+MAIN	1	Titel-/Deckblatt Title page/cover sheet Page de titre/de garde			
	=DOC	+MAIN	2	Drahtfarben Wire colours Colours de fil			
	=DOC	+MAIN	3	Strukturkennzeichenübersicht Structure identifier overview Aperçu des identificateurs de structure			
==S1	=01	+1	1	Einspeisung Power Supply Alimentation			
	=01	+1	2	Antrieb drive entraînement			
	=01	+1	3	Steuerung Control Commande			
	=01	+1	4	Stecker Plug Connecteur			
==DATA	=DOC	+TERMINAL	1	Klemmenaufreihplan Terminal line-up diagram Plan des bornes associables			
	=DOC	+CONNECTOR	1	Steckerübersicht Plug overview Aperçu des connecteurs			
	=DOC	+COMPONENT	1	Artikelstückliste Parts list Liste des composants électriques			
	=DOC	+COMPONENT	2	Artikelstückliste Parts list Liste des composants électriques			
	=DOC	+CABLE	1	Kabelplan Cable diagram Représentation des câbles			
	=DOC	+CABLE	2	Kabelplan Cable diagram Représentation des câbles			

Functional assignment	Higher-level function	Mounting location	Page	Page description	Modification		
					Index	Modification number	Modification date

+MAIN/3

==S1=01+1/1



Date	04.07.2013
Ed. by	saladi_r
Appr	
Modification	Date
Name	Original

Page name	Inhaltsverzeichnis
	Table of contents
	Sommaire

Plant designation	SFT*62*
Drawing number	505134

Machine number	== GEN
	= DOC
	+ PAG
Commission number	
Total Pg 14	Page 1

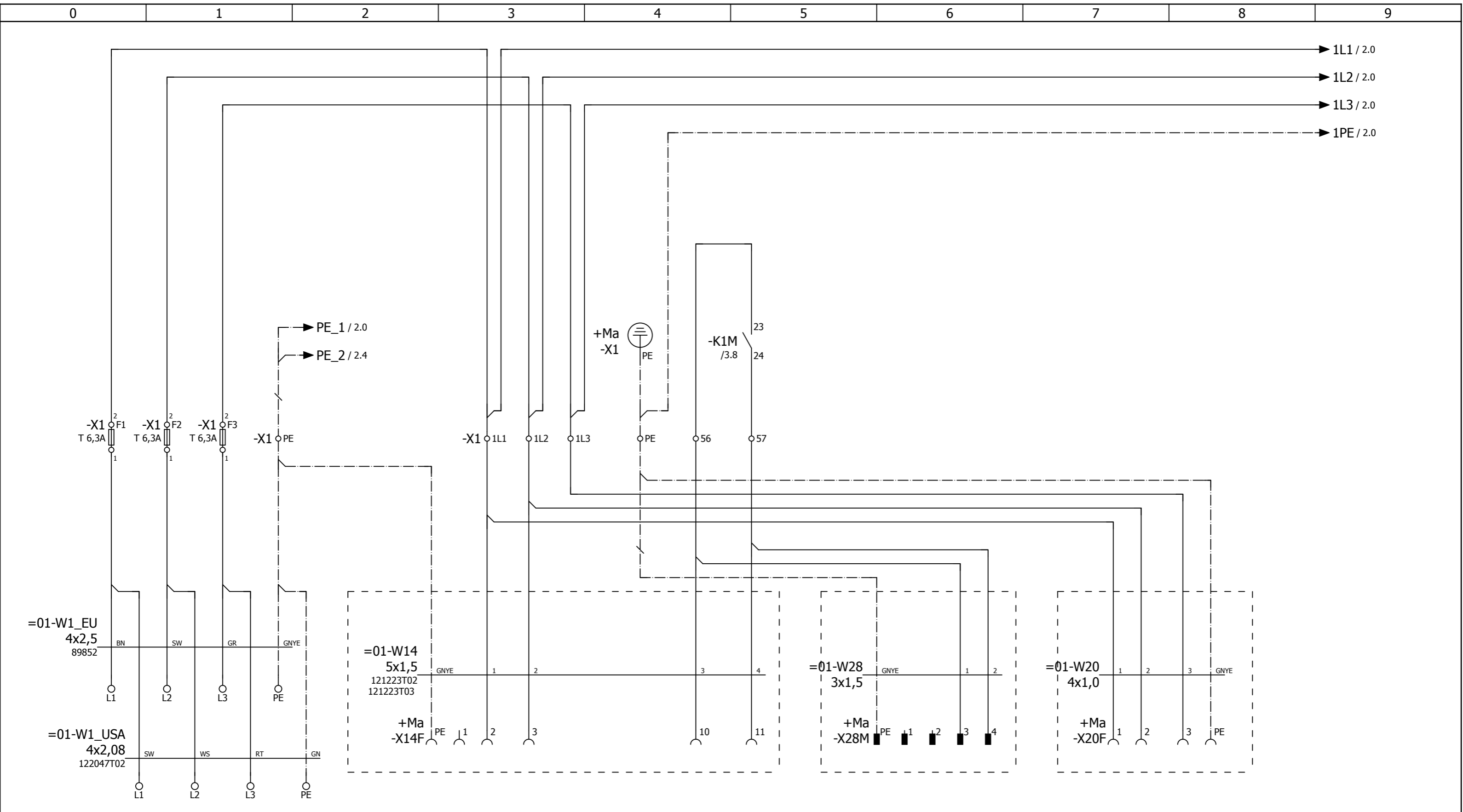

Netzeinspeisung
Mains supply
Branchement au reseau

3x200-420VAC 50/60Hz

Als Option
As option
Comme option

Transfertisch
Transfer conveyor
Tapis de transfer

Als Option
As option
Comme option

Ausrollmaschine
Dough sheeter
Laminoir

Als Option
As option
Comme option

Rondinett

Modification	Date	Name	Original

Date	13.01.2014
Ed. by	Ryser_h
Appr	
Page name	Einspeisung Power Supply Alimentation

Plant designation	SFT*62*
Drawing number	505134

Machine number	== S1
	= 01
Commission number	+ 1
Total Pg 14	Page 1

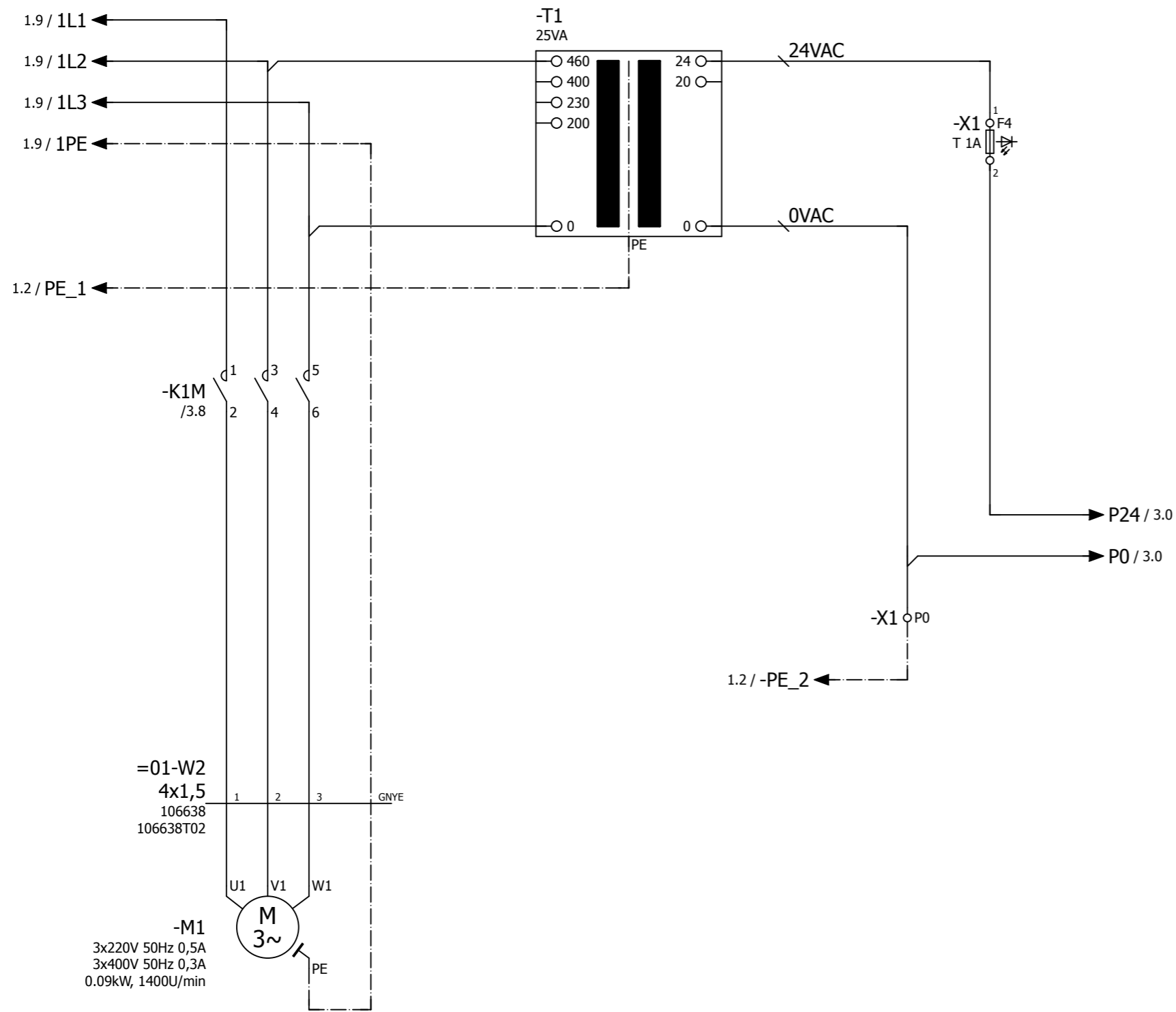

Bandantrieb
Belt drive
Entrainm. du tapis

Steuerspannungstransformator
Control voltage trans
Transformateur de tension de com

Modification	Date	Name	Original

Date	13.01.2014
Ed. by	Ryser_h
Appr	
Page name	Antrieb drive entraînement

Plant designation	SFT*62*
Drawing number	505134

Machine number	== S1
	= 01
Commission number	+ 1
Total Pg 14	Page 2

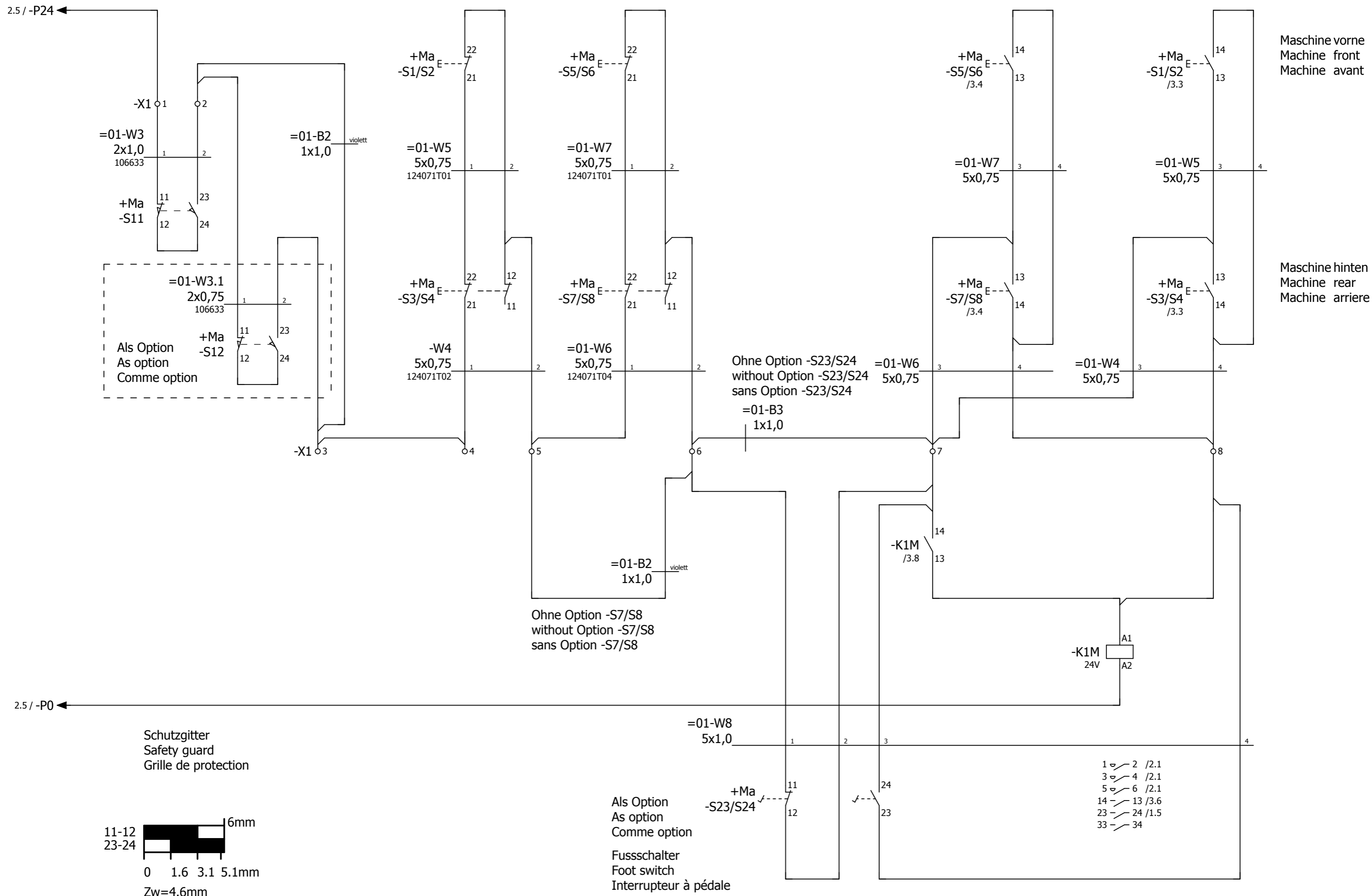

Date	13.01.2014
Ed. by	Ryser_h
Appr	
Original	
Modification	
Date	
Name	

Page name
Steuerung
Control
Commande

Plant designation
SFT*62*

Drawing number
505134

Machine number
== S1
= 01

Commission number
+ 1

Total Pg 14 Page 3

+Ma-X14F

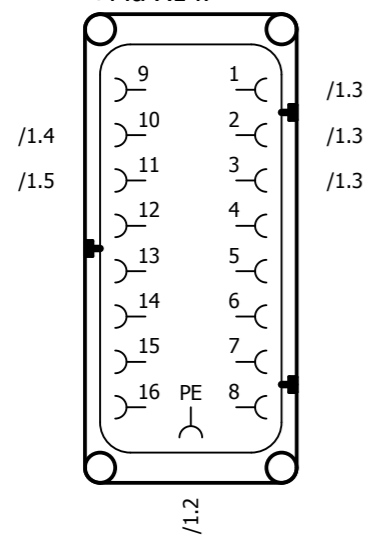

+Ma-X28M

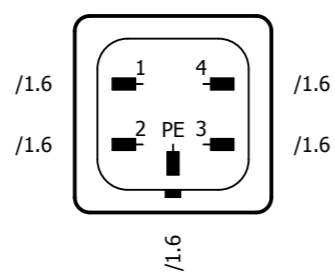

+Ma-X20F

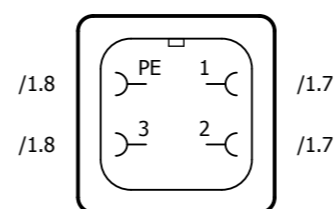

+Ma-X14F =

+Ma-X28M =

+Ma-X20F =

Modification	Date	Name	Date	13.08.2013
			Ed. by	Ryser_h
			Appr	
			Original	

Page name	Stecker
	Plug
	Connecteur

Plant designation	SFT*62*
Drawing number	505134

Machine number	== S1
	= 01
Commission number	+ 1
Total Pg 14	Page 4

Klemmenaufreihplan/ Terminal line-up diagram/ Plan des bornes associables/

Klemmenleiste
Terminal strip
Bornier

==S1=01+1-X1

Klemme Terminal Borne	Brücke Jumper Pont	Artikelnummer Part number Numéro d'article	Seite Page Page	Klemmenzubehör Terminal accessories Accessoire de borne	Abschlussplatte End plate Flasque de fin	Brücke Jumper Pont	Endklammer für TS35 End piece Piece finale
F1	o	52127	==S1=01+1/1	11053			
F2	o	52127	==S1=01+1/1	11053			
F3	o	52127	==S1=01+1/1	11053			
F4	o	52128	==S1=01+1/2	8934	52130		52131
PE	o	52122	==S1=01+1/1				
1L1	o	52120	==S1=01+1/1				
1L2	o	52120	==S1=01+1/1				
1L3	o	52120	==S1=01+1/1				
PE	o	52122	==S1=01+1/1				
56	o	52120	==S1=01+1/1				
57	o	52120	==S1=01+1/1				
P0	o	52120	==S1=01+1/2				
1	o	52120	==S1=01+1/3				
2	o	52120	==S1=01+1/3				
3	o	52120	==S1=01+1/3				
4	o	52120	==S1=01+1/3				
5	o	52120	==S1=01+1/3				
6	o	52120	==S1=01+1/3				
7	o	52120	==S1=01+1/3				
8	o	52120	==S1=01+1/3		52124		52131

==S1=01+1/4

+CONNECTOR/1



Date	13.01.2014
Ed. by	Ryser_h
Appr	
Original	
Modification	
Date	
Name	

Page name	Klemmenaufreihplan
	Terminal line-up diagram
	Plan des bornes associables

Plant designation	SFT*62*
Drawing number	505134

Machine number	== DATA
	= DOC
Commission number	+ TERMINAL
Total Pg 14	Page 1

Steckerübersicht - Plug overview - Aperçu des connecteurs -

Steckerbezeichnung Plug designation Désignation de connecteur	Artikelnummer Part number Numéro d'article	Normal Normal Normal	+	1	Seite / Spalte Page / column Page / Colonne
==S1=01+Ma-X14F	50023;51276	16	+	1	==S1=01+1/4.1
==S1=01+Ma-X20F	50021;50725	3	+	1	==S1=01+1/4.5
==S1=01+Ma-X28M	50314;51271	4	+	1	==S1=01+1/4.2

Artikelstückliste / Parts list / Liste d'articles /

Betriebsmittelkennzeichen Device tag Désignation de composant	Art.-Nr.: Prt.-Nr.: Art.-ref.:	Beschreibung Description Description	Betriebsmittelkennzeichen Device tag Désignation de composant	Art.-Nr.: Prt.-Nr.: Art.-ref.:	Beschreibung Description Description	
==S1=01+1-K1M	53436	Kleinleistungsschutz Contactor miniature Contacteur de petit calibre	==S1=01+Ma-S3/S4	53998	Tastenschild schwarz mit O weiss Sign keys black with O white Inscription clés noir avec O blanc	
==S1=01+1-K1M	53438	Hilfskontaktblock 2S Contact component 2S Module de contacts auxiliaires	==S1=01+Ma-S3/S4	51200	Hilfskontaktblock 1S Contact component 1S Module de contacts auxiliaires	
==S1=01+1-M1	50374	AC-Getr.-Motor m. Flansch Gear motor with flange Moteur-reducteur avec flasque	==S1=01+Ma-S3/S4	51204	Hilfskontakt 1Ö Contact auxiliary 1O Contact auxiliaire 1O	
==S1=01+1-M1	oder	oder or ou	==S1=01+Ma-S3/S4	53474	Schutzkappe ZBA 708 Cap, protective ZBA 708 Cache de protection ZBA 708	für 2 flache Tasten
==S1=01+1-M1	50375	AC-Getr.-Motor m. Flansch Gear motor with flange Moteur-reducteur avec flasque	==S1=01+Ma-S5/S6	53428	Zweifachtaster 2 Push-button 2 Bouton-poussoir	
==S1=01+1-T1	50000	Einphasentransformator Single-phase transformer Autotransformateur monophasé	==S1=01+Ma-S5/S6	53997	Tastenschild weiss mit I schwarz Sign keys white with I black Inscription clés blanc avec I noir	
==S1=01+Ma-S1/S2	53428	Zweifachtaster 2 Push-button 2 Bouton-poussoir	==S1=01+Ma-S5/S6	53998	Tastenschild schwarz mit O weiss Sign keys black with O white Inscription clés noir avec O blanc	
==S1=01+Ma-S1/S2	53997	Tastenschild weiss mit I schwarz Sign keys white with I black Inscription clés blanc avec I noir	==S1=01+Ma-S5/S6	51200	Hilfskontaktblock 1S Contact component 1S Module de contacts auxiliaires	
==S1=01+Ma-S1/S2	53998	Tastenschild schwarz mit O weiss Sign keys black with O white Inscription clés noir avec O blanc	==S1=01+Ma-S5/S6	51204	Hilfskontakt 1Ö Contact auxiliary 1O Contact auxiliaire 1O	
==S1=01+Ma-S1/S2	51200	Hilfskontaktblock 1S Contact component 1S Module de contacts auxiliaires	==S1=01+Ma-S5/S6	53474	Schutzkappe ZBA 708 Cap, protective ZBA 708 Cache de protection ZBA 708	für 2 flache Tasten
==S1=01+Ma-S1/S2	51204	Hilfskontakt 1Ö Contact auxiliary 1O Contact auxiliaire 1O	==S1=01+Ma-S7/S8	53428	Zweifachtaster 2 Push-button 2 Bouton-poussoir	
==S1=01+Ma-S1/S2	53474	Schutzkappe ZBA 708 Cap, protective ZBA 708 Cache de protection ZBA 708	==S1=01+Ma-S7/S8	53997	Tastenschild weiss mit I schwarz Sign keys white with I black Inscription clés blanc avec I noir	
==S1=01+Ma-S3/S4	53428	Zweifachtaster 2 Push-button 2 Bouton-poussoir	==S1=01+Ma-S7/S8	53998	Tastenschild schwarz mit O weiss Sign keys black with O white Inscription clés noir avec O blanc	
==S1=01+Ma-S3/S4	53997	Tastenschild weiss mit I schwarz Sign keys white with I black Inscription clés blanc avec I noir	==S1=01+Ma-S7/S8	51200	Hilfskontaktblock 1S Contact component 1S Module de contacts auxiliaires	

+CONNECTOR/1

2

RONDO
Dough-how & more.

Date	13.08.2013
Ed. by	Ryser_h
Appr	
Original	
Modification	Date
Name	

Page name
Artikelstückliste
Parts list
Liste des composants électriques

Plant designation
SFT*62*
Drawing number
505134

Machine number
Commission number

== DATA
= DOC
+ COMPONENT
Total Pg 14 Page 1

Artikelstückliste / Parts list / Liste d'articles /

Betriebsmittelkennzeichen Device tag Désignation de composant	Art.-Nr.: Prt.-Nr.: Art.-ref.:	Beschreibung Description Description	
==S1=01+Ma-S7/S8	51204	Hilfskontakt 1Ö Contact auxiliary 1O Contact auxiliaire 1O	
==S1=01+Ma-S7/S8	53474	Schutzkappe ZBA 708 Cap, protective ZBA 708 Cache de protection ZBA 708	für 2 flache Tasten
==S1=01+Ma-S11	11965a	Klein-Grenztaster 1Ö + 1S Limit switch 1Ö + 1S Commutateur de fin de course 1Ö + 1S	
==S1=01+Ma-S12	11965a	Klein-Grenztaster 1Ö + 1S Limit switch 1Ö + 1S Commutateur de fin de course 1Ö + 1S	
==S1=01+Ma-S23/S24	11975	Fussschalter Foot switch Interrupteur à pédale	
==S1=01+Ma-X14F	50023	Steckdoseneinsatz 16p+PE Socket insert 16p+PE Insert de prise femelle 16p+PE	
==S1=01+Ma-X14F	51276	Tuellengehaeuse 16p/M25s Grommet housing 16p Boite de passe-cable 16p	Kabeleinführung seitlich Cable entry Entrée de câbles
==S1=01+Ma-X20F	50021	Steckdoseneinsatz 3p+PE Socket insert 3p+PE Insert de prise femelle 3p+PE	
==S1=01+Ma-X20F	50725	Anbaugehaeuse Attached housing Boite adaptable	Längsbügel Single lever Double levers
==S1=01+Ma-X28M	50314	Steckereinsatz 4p+PE Plug insert 4p+PE Insert de prise male 4p+PE	
==S1=01+Ma-X28M	51271	Tuellengehaeuse M20s Grommet housing M20s Boite de passe-cable M20s	

+CABLE/1



Date	13.08.2013
Ed. by	Ryser_h
Appr	
Modification	Date
Name	Original

Page name	Artikelstückliste
Parts list	
Liste des composants électriques	

Plant designation	SFT*62*
Drawing number	505134

Machine number	== DATA
	= DOC
Commission number	+ COMPONENT
Total Pg 14	Page 2

Kabelplan - Cable diagram - Plan de câblage -

Cable name ==S1=01+1-B2			Cross-section 1,0 mm ²	Part number 13260;13260		
Cable type TT			Cable length			
No. of conductors 1			Bemerkung Remark Remarque			
Seite / Spalte Page / column Page / Colonne	Anschluss Connection point Raccordement	Zielbezeichnung von Target designation from Désignation de destination de	← Ader Conductor Conducteur →	Zielbezeichnung nach Target designation to Désignation de destination vers	Anschluss Connection point Raccordement	Seite / Spalte Page / column Page / Colonne
/3.1	2	=01 +1 -X1	← violett →	=01 +1 -X1	3	/3.2
/3.3	5	=01 +1 -X1	← violett →	=01 +1 -X1	6	/3.5

Cable name ==S1=01+1-W2			Cross-section 1,5 mm ²	Part number 12753		
Cable type K-M JZ			Cable length			
No. of conductors 4			Bemerkung Remark 106638 106638T02 Remarque			
Seite / Spalte Page / column Page / Colonne	Anschluss Connection point Raccordement	Zielbezeichnung von Target designation from Désignation de destination de	← Ader Conductor Conducteur →	Zielbezeichnung nach Target designation to Désignation de destination vers	Anschluss Connection point Raccordement	Seite / Spalte Page / column Page / Colonne
/2.1	2	=01 +1 -K1M	← 1 →	=01 +1 -M1	U1	/2.1
/2.1	4	=01 +1 -K1M	← 2 →	=01 +1 -M1	V1	/2.1
/2.1	6	=01 +1 -K1M	← 3 →	=01 +1 -M1	W1	/2.1
/1.4	PE	=01 +1 -X1	← GNYE →	=01 +1 -M1	PE	/2.1

Cable name ==S1=01+1-B3			Cross-section 1,0 mm ²	Part number 13260		
Cable type TT			Cable length			
No. of conductors 1			Bemerkung Remark Remarque			
Seite / Spalte Page / column Page / Colonne	Anschluss Connection point Raccordement	Zielbezeichnung von Target designation from Désignation de destination de	← Ader Conductor Conducteur →	Zielbezeichnung nach Target designation to Désignation de destination vers	Anschluss Connection point Raccordement	Seite / Spalte Page / column Page / Colonne
			← violett →			
/3.5	6	=01 +1 -X1	← →	=01 +1 -X1	7	/3.6

Cable name ==S1=01+1-W3			Cross-section 1,0 mm ²	Part number 13070		
Cable type K-M OZ			Cable length			
No. of conductors 2			Bemerkung Remark 106633 Remarque			
Seite / Spalte Page / column Page / Colonne	Anschluss Connection point Raccordement	Zielbezeichnung von Target designation from Désignation de destination de	← Ader Conductor Conducteur →	Zielbezeichnung nach Target designation to Désignation de destination vers	Anschluss Connection point Raccordement	Seite / Spalte Page / column Page / Colonne
/3.1	1	=01 +1 -X1	← 1 →	=01 +Ma -S11	11	/3.1
/3.1	2	=01 +1 -X1	← 2 →	=01 +Ma -S11	23	/3.1

Cable name ==S1=01+1-W1_EU			Cross-section 2,5 mm ²	Part number 13990		
Cable type PUR			Cable length			
No. of conductors 4			Bemerkung Remark 89852 Remarque			
Seite / Spalte Page / column Page / Colonne	Anschluss Connection point Raccordement	Zielbezeichnung von Target designation from Désignation de destination de	← Ader Conductor Conducteur →	Zielbezeichnung nach Target designation to Désignation de destination vers	Anschluss Connection point Raccordement	Seite / Spalte Page / column Page / Colonne
/1.0	F1	=01 +1 -X1	← BN →			/1.0
/1.1	F2	=01 +1 -X1	← SW →			/1.1
/1.1	F3	=01 +1 -X1	← GR →			/1.1
/1.1	PE	=01 +1 -X1	← GNYE →			/1.1

Cable name ==S1=01+1-W3.1			Cross-section 0,75 mm ²	Part number 13069		
Cable type K-M OZ			Cable length			
No. of conductors 2			Bemerkung Remark 106633 Remarque			
Seite / Spalte Page / column Page / Colonne	Anschluss Connection point Raccordement	Zielbezeichnung von Target designation from Désignation de destination de	← Ader Conductor Conducteur →	Zielbezeichnung nach Target designation to Désignation de destination vers	Anschluss Connection point Raccordement	Seite / Spalte Page / column Page / Colonne
/3.1	2	=01 +1 -X1	← 1 →	=01 +Ma -S12	11	/3.1
/3.2	3	=01 +1 -X1	← 2 →	=01 +Ma -S12	23	/3.2

Cable name ==S1=01+1-W1_USA			Cross-section 2,08 mm ²	Part number 13555		
Cable type PUR			Cable length			
No. of conductors 4			Bemerkung Remark 122047T02 Remarque			
Seite / Spalte Page / column Page / Colonne	Anschluss Connection point Raccordement	Zielbezeichnung von Target designation from Désignation de destination de	← Ader Conductor Conducteur →	Zielbezeichnung nach Target designation to Désignation de destination vers	Anschluss Connection point Raccordement	Seite / Spalte Page / column Page / Colonne
/1.0	F1	=01 +1 -X1	← SW →			/1.0
/1.1	F2	=01 +1 -X1	← WS →			/1.1
/1.1	F3	=01 +1 -X1	← RT →			/1.1
/1.1	PE	=01 +1 -X1	← GN →			/1.2

Cable name ==S1=01+1-W4			Cross-section 0,75 mm ²	Part number 13448		
Cable type K-M JZ			Cable length			
No. of conductors 5			Bemerkung Remark 124071T02 Remarque			
Seite / Spalte Page / column Page / Colonne	Anschluss Connection point Raccordement	Zielbezeichnung von Target designation from Désignation de destination de	← Ader Conductor Conducteur →	Zielbezeichnung nach Target designation to Désignation de destination vers	Anschluss Connection point Raccordement	Seite / Spalte Page / column Page / Colonne
/3.3	4	=01 +1 -X1	← 1 →	=01 +Ma -S3/S4	21	/3.3
/3.3	5	=01 +1 -X1	← 2 →	=01 +Ma -S3/S4	12	/3.3
/3.6	7	=01 +1 -X1	← 3 →	=01 +Ma -S3/S4	13	/3.8
/3.8	8	=01 +1 -X1	← 4 →	=01 +Ma -S3/S4	14	/3.8
			← GNYE →			

+COMPONENT/2

2



Date	13.08.2013
Ed. by	Ryser_h
Appr	
Original	
Modification	Date Name

Page name
Kabelplan
Cable diagram
Représentation des câbles

Plant designation
SFT*62*
Drawing number
505134

Machine number
Commission number
Total Pg 14 Page 1

== DATA
= DOC
+ CABLE

Kabelplan - Cable diagram - Plan de câblage -

Cable name ==S1=01+1-W5		Cross-section 0,75 mm²	Part number 13448			
Cable type K-M JZ		Cable length				
No. of conductors 5		Bemerkung Remark 124071T01 Remarque				
Seite / Spalte Page / column Page / Colonne	Anschluss Connection point Raccordement	Zielbezeichnung von Target designation from Désignation de destination de	Ader Conductor Conducteur	Zielbezeichnung nach Target designation to Désignation de destination vers	Anschluss Connection point Raccordement	Seite / Spalte Page / column Page / Colonne
/3.3	21	=01 +Ma -S1/S2	← 1 →	=01 +Ma -S3/S4	22	/3.3
/3.3	22	=01 +Ma -S1/S2	← 2 →	=01 +Ma -S3/S4	12	/3.3
/3.8	13	=01 +Ma -S1/S2	← 3 →	=01 +Ma -S3/S4	13	/3.8
/3.8	14	=01 +Ma -S1/S2	← 4 →	=01 +Ma -S3/S4	14	/3.8
			← GNYE →			

/3.6	7	=01 +1 -X1	← 2 →	=01 +Ma -S23/S24	12	/3.5
/3.6	14	=01 +1 -K1M	← 3 →	=01 +Ma -S23/S24	24	/3.6
/3.8	8	=01 +1 -X1	← 4 →	=01 +Ma -S23/S24	23	/3.6
			← GNYE →			

Cable name ==S1=01+1-W6		Cross-section 0,75 mm²	Part number 13448			
Cable type K-M JZ		Cable length				
No. of conductors 5		Bemerkung Remark 124071T04 Remarque				
Seite / Spalte Page / column Page / Colonne	Anschluss Connection point Raccordement	Zielbezeichnung von Target designation from Désignation de destination de	Ader Conductor Conducteur	Zielbezeichnung nach Target designation to Désignation de destination vers	Anschluss Connection point Raccordement	Seite / Spalte Page / column Page / Colonne
/3.3	5	=01 +1 -X1	← 1 →	=01 +Ma -S7/S8	21	/3.4
/3.5	6	=01 +1 -X1	← 2 →	=01 +Ma -S7/S8	12	/3.4
/3.6	7	=01 +1 -X1	← 3 →	=01 +Ma -S7/S8	13	/3.7
/3.8	8	=01 +1 -X1	← 4 →	=01 +Ma -S7/S8	14	/3.7
			← GNYE →			

Cable name ==S1=01+1-W14		Cross-section 1,5 mm²	Part number 13370			
Cable type K-M JZ		Cable length				
No. of conductors 5		Bemerkung Remark 121223T02 121223T03 Remarque				
Seite / Spalte Page / column Page / Colonne	Anschluss Connection point Raccordement	Zielbezeichnung von Target designation from Désignation de destination de	Ader Conductor Conducteur	Zielbezeichnung nach Target designation to Désignation de destination vers	Anschluss Connection point Raccordement	Seite / Spalte Page / column Page / Colonne
/1.3	1L1	=01 +1 -X1	← 1 →	=01 +Ma -X14F	2	/1.3
/1.3	1L2	=01 +1 -X1	← 2 →	=01 +Ma -X14F	3	/1.3
/1.4	56	=01 +1 -X1	← 3 →	=01 +Ma -X14F	10	/1.4
/1.5	57	=01 +1 -X1	← 4 →	=01 +Ma -X14F	11	/1.5
/1.1	PE	=01 +1 -X1	← GNYE →	=01 +Ma -X14F	PE	/1.2

Cable name ==S1=01+1-W7		Cross-section 0,75 mm²	Part number 13448			
Cable type K-M JZ		Cable length				
No. of conductors 5		Bemerkung Remark 124071T01 Remarque				
Seite / Spalte Page / column Page / Colonne	Anschluss Connection point Raccordement	Zielbezeichnung von Target designation from Désignation de destination de	Ader Conductor Conducteur	Zielbezeichnung nach Target designation to Désignation de destination vers	Anschluss Connection point Raccordement	Seite / Spalte Page / column Page / Colonne
/3.4	21	=01 +Ma -S5/S6	← 1 →	=01 +Ma -S7/S8	22	/3.4
/3.4	22	=01 +Ma -S5/S6	← 2 →	=01 +Ma -S7/S8	12	/3.4
/3.7	13	=01 +Ma -S5/S6	← 3 →	=01 +Ma -S7/S8	13	/3.7
/3.7	14	=01 +Ma -S5/S6	← 4 →	=01 +Ma -S7/S8	14	/3.7
			← GNYE →			

Cable name ==S1=01+1-W20		Cross-section 1,0 mm²	Part number 13030			
Cable type K-M JZ		Cable length				
No. of conductors 4		Bemerkung Remark Remarque				
Seite / Spalte Page / column Page / Colonne	Anschluss Connection point Raccordement	Zielbezeichnung von Target designation from Désignation de destination de	Ader Conductor Conducteur	Zielbezeichnung nach Target designation to Désignation de destination vers	Anschluss Connection point Raccordement	Seite / Spalte Page / column Page / Colonne
/1.3	1L1	=01 +1 -X1	← 1 →	=01 +Ma -X20F	1	/1.7
/1.3	1L2	=01 +1 -X1	← 2 →	=01 +Ma -X20F	2	/1.7
/1.3	1L3	=01 +1 -X1	← 3 →	=01 +Ma -X20F	3	/1.8
/1.4	PE	=01 +1 -X1	← GNYE →	=01 +Ma -X20F	PE	/1.8

Cable name ==S1=01+1-W8		Cross-section 1,0 mm²	Part number 13009			
Cable type K-M JZ		Cable length				
No. of conductors 5		Bemerkung Remark Remarque				
Seite / Spalte Page / column Page / Colonne	Anschluss Connection point Raccordement	Zielbezeichnung von Target designation from Désignation de destination de	Ader Conductor Conducteur	Zielbezeichnung nach Target designation to Désignation de destination vers	Anschluss Connection point Raccordement	Seite / Spalte Page / column Page / Colonne
/3.5	6	=01 +1 -X1	← 1 →	=01 +Ma -S23/S24	11	/3.5

Cable name ==S1=01+1-W28		Cross-section 1,5 mm²	Part number 12752			
Cable type K-M JZ		Cable length				
No. of conductors 3		Bemerkung Remark Remarque				
Seite / Spalte Page / column Page / Colonne	Anschluss Connection point Raccordement	Zielbezeichnung von Target designation from Désignation de destination de	Ader Conductor Conducteur	Zielbezeichnung nach Target designation to Désignation de destination vers	Anschluss Connection point Raccordement	Seite / Spalte Page / column Page / Colonne
/1.4	56	=01 +1 -X1	← 1 →	=01 +Ma -X28M	3	/1.6
/1.5	57	=01 +1 -X1	← 2 →	=01 +Ma -X28M	4	/1.6
/1.4	PE	=01 +1 -X1	← GNYE →	=01 +Ma -X28M	PE	/1.6



Modification	Date	Name	Date	13.08.2013	Page name	Kabelplan	Plant designation	SFT*62*	Machine number	== DATA
			Ed. by	Ryser_h		Cable diagram				= DOC
			Appr			Représentation des câbles	Drawing number	505134	Commission number	+ CABLE
			Original						Total Pg 14	Page 2

RONDO

Dough-how & more.

RONDO Burgdorf AG

Heimiswilstrasse 42

CH-3400 Burgdorf

Tel.: +41 34 420 81 11

Fax: +41 34 420 81 99

Website: www.rondo-online.com

E-mail: service@ch.rondo-online.com

Maschine	Machine	Machine	:Schneidetisch variabel
Modelnummer	Model number	Numéro de model	:SFT*62V*
Schema Nr.	Drawing number	Numéro de dessin	:505135a
Auftragsnummer	Commission number	Numéro de commande	:
Maschinenummer	Machine number	Numéro de machine	:

Manufacturer (company)

RONDO Burgdorf AG

CH-3400 Burgdorf

Company / customer

City

Project path

L:\Electric P8\EPLAN_DATA\Projekte\RDB\5051xx\505135a.elk

Project path .PDF

G:\PROJEKTE\PDF\PDF_Schema SMB

Remarks

Responsible for project

HU.Ryser

Created on 01.11.2012

Edit date 04.12.2014

by (short name) ryser_h

Number of pages 17

Drahtfarben - Wire colours - Coueurs de fil -

Wechselspannung - AC voltage - Tension alternative -

Phase	L1	Phase	L1	Phase	L1	schwarz - black - noir -
Phase	L2	Phase	L2	Phase	L2	schwarz - black - noir -
Phase	L3	Phase	L3	Phase	L3	schwarz - black - noir -
Neutralleiter	N	neutral conductor	N	conducteur neutre	N	hellblau - light blue - bleu clair -
Schutzleiter	PE	protective wire	PE	conducteur de protection	PE	gelb/grün - yellow/green - jaune/vert -
Steuerspannung vor Transformator	L	Control voltage before transformer	L	Tension de comm. avant transformateur	L	schwarz - black - noir -
Neutralleiter vor Transformator	N	Neutral conductor before transformer	N	Conducteur neutre avant transformateur	N	hellblau - light blue - bleu clair -
Steuerspannung nach Transformator	**VAC	Control voltage after transformer	**VAC	Tension de commande après transformateur	**VAC	rot - red - rouge -
Neutralleiter nach Transformator	0VAC	Neutral conductor after transformer	0VAC	Conducteur neutre avant transformateur	0VAC	rot/weiss - red/white - rouge/blanc -
Steuerspannung geschaltet	**VAC	Control voltage switched	**VAC	Tension de commande branché	**VAC	lila - purple - lilas -

Gleichspannung - DC voltage - Tension continue -

Hauptstromkreise	L+	Main circuits	L+	Circuit principal	L+	schwarz - black - noir -
Hauptstromkreise	L-	Main circuits	L-	Circuit principal	L-	schwarz - black - noir -
Steuerstromkreise	+VDC	Control circuits	+VDC	Circuit de commande	+VDC	blau - blue - bleu -
Steuerstromkreise	0VDC	Control circuits	0VDC	Circuit de commande	0VDC	blau/weiss - blue/white - bleu/blanc -
Steuerstromkreise geschaltet	**VDC	Control circuits switched	**VDC	Circuit de commande branché	**VDC	violett - violet - violet -

Analogsignale - Analog signals - Signaux analogiques -

Sollwert/Istwert	+	Set value/Actual value	+	Valeur théoretique/effective	+	grau - grey - gris -
Regelerde	-	Control ground	-	Terre de régulation	-	weiss - white - blanc -

Fremdspannung - External voltage - Tension d'origine étrangères -

Steuerstromkreise extern	VAC/DC	Control circuits external	VAC/DC	Circuit de commande externe	VAC/DC	orange - orange - orange -
--------------------------	--------	---------------------------	--------	-----------------------------	--------	----------------------------



Date	14.01.2015		
Ed. by	ryser_h		
Appr			
Modification	Date	Name	Original

Page name	Drahtfarben
Wire colours	Wire colours
Colours de fil	Colours de fil

Plant designation	SFT*62V*
Drawing number	505135a

Machine number	== GEN
	= DOC
Commission number	+ MAIN
Total Pg 17	Page 2

Strukturkennzeichenübersicht / Structure identifier overview / Aperçu des identificateurs de structure /

Funktionale Zuordnung Functional assignment Attribution fonctionnelle	Beschreibung Description Description
==GEN	Allgemeines General Général
==S1	Sektion 1 Section 1 Section 1
==DATA	Daten Data Données

Anlage Installation Installation	Beschreibung Description Description
=01	Schneidetisch v=var Cutting table v=var Table de decoupe v=var
=50	Schnittstelle für Kalibrierer ZKWAA Interface for Calibrator ZKWAA Interface pour Calibreur ZKWAA
=ZKWAA	Kalibrierer Autonom Calibrator independent Calibreur autonome
=DOC	Dokumentation Documentation Documentation

Einbauort Mounting location Lieu de montage	Beschreibung Description Description
+MAIN	Hauptverzeichnis Main directory Dossier principal
+PAG	Inhaltsverzeichnis Table of contents Sommaire
+1	Steuerkasten Control box Boîte de commande
+2	Steuerkasten Front Control box front Boîte de commande avant

+Ma	an Maschine on machine sur machine
+TERMINAL	Klemmen Terminals Bornes
+CONNECTOR	Stecker Plug Connecteur
+COMPONENT	Artikel Item Article
+CABLE	Kabel Cable Cables

Inhaltsverzeichnis - Table of contents - Sommaire -

Functional assignment	Higher-level function	Mounting location	Page	Page description	Modification		
					Index	Modification number	Modification date
==GEN	=DOC	+MAIN	1	Titel-/Deckblatt Title page/cover sheet Page de titre/de garde	a	42425.4	14.08.2014
	=DOC	+MAIN	2	Drahtfarben Wire colours Colours de fil			
	=DOC	+MAIN	3	Strukturkennzeichenübersicht Structure identifier overview Aperçu des identificateurs de structure			
==S1	=01	+1	1	Einspeisung Power Supply Alimentation			
	=01	+1	2	Antrieb drive entraînement	a	42425.4	14.08.2014
	=01	+1	3	Steuerung Control Commande			
	=01	+1	4	Stecker Plug Connecteur			
	=50	+1	1	Interface ZKWA60* Interface ZKWA60* D'interface ZKWA60*			
	=50	+1	2	Stecker Plug Connecteur			
==DATA	=DOC	+TERMINAL	1	Klemmenaufreihplan Terminal line-up diagram Plan des bornes associables			
	=DOC	+CONNECTOR	1	Steckerübersicht Plug overview Aperçu des connecteurs			
	=DOC	+COMPONENT	1	Artikelstückliste Parts list Liste des composants électriques			
	=DOC	+COMPONENT	2	Artikelstückliste Parts list Liste des composants électriques			
	=DOC	+CABLE	1	Kabelplan Cable diagram Représentation des câbles			

Functional assignment	Higher-level function	Mounting location	Page	Page description	Modification		
					Index	Modification number	Modification date
==DATA	=DOC	+CABLE	2	Kabelplan Cable diagram Représentation des câbles			
	=DOC	+CABLE	3	Kabelplan Cable diagram Représentation des câbles			

+MAIN/3

==S1=01+1/1



Date	14.01.2015
Ed. by	ryser_h
Appr	
Modification	Date
Name	Original

Page name
Inhaltsverzeichnis
Table of contents
Sommaire

Plant designation
SFT*62V*
Drawing number
505135a

Machine number
Commission number
Total Pg 17
Page 1

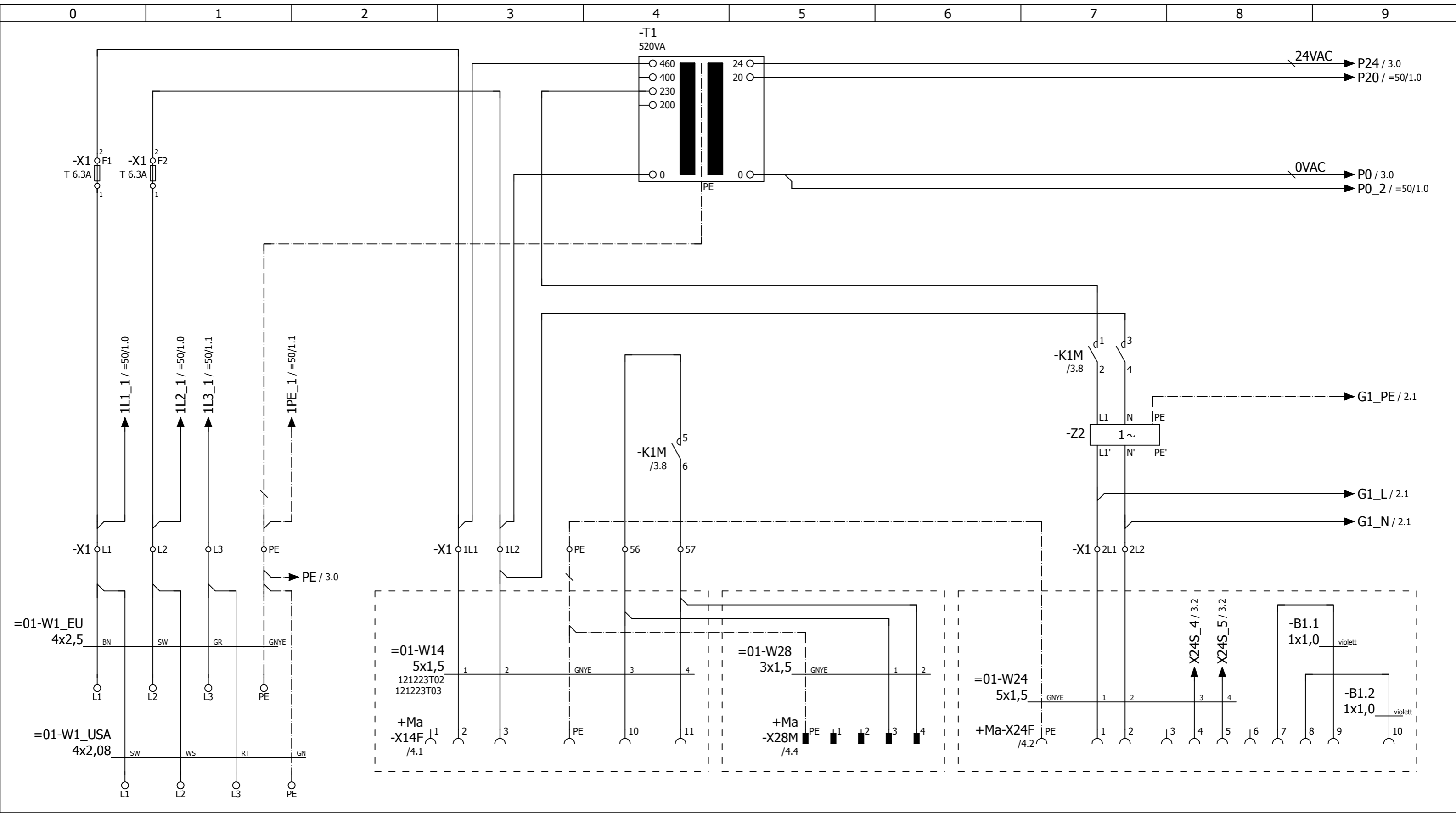

Netzeinspeisung
Mains supply
Branchement au reseau

1x200-460VAC 50/60Hz

oder
or
ou

3x200-460VAC 50/60Hz

mit
with
avec ZKWA

Als Option
As option
Comme option

Transfertisch
Transfer conveyor
Tapis de transfer

Als Option
As option
Comme option

Ausrollmaschine
Dough sheeter
Laminoir

Als Option
As option
Comme option

Schneidest. mit Antrieb
Driven cutting unit
Dispositif decoupe-entraîn.

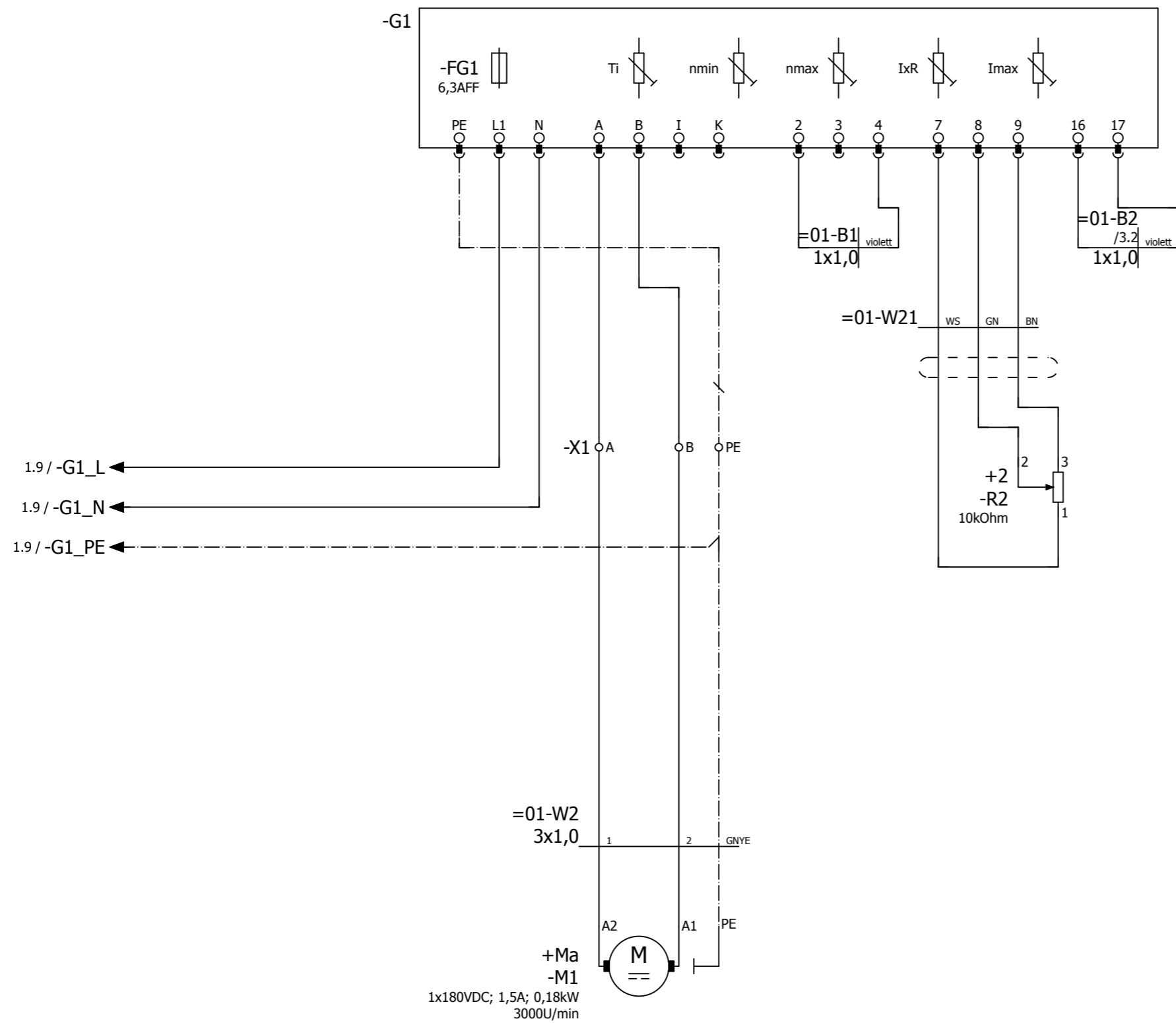

Bandantriebssteuerung
 Contr. unit for conv
 Comm. pour entr. du tapis

a	42425.4	14.08.2014	Ryser_h	Date	04.12.2014
				Ed. by	ryser_h
				Appr	
Modification	Date	Name	Original		

Page name
Antrieb
 drive
 entraînement

Plant designation
SFT*62V*
 Drawing number
505135a

Machine number	== S1
	= 01
Commission number	+ 1
Total Pg 17	Page 2

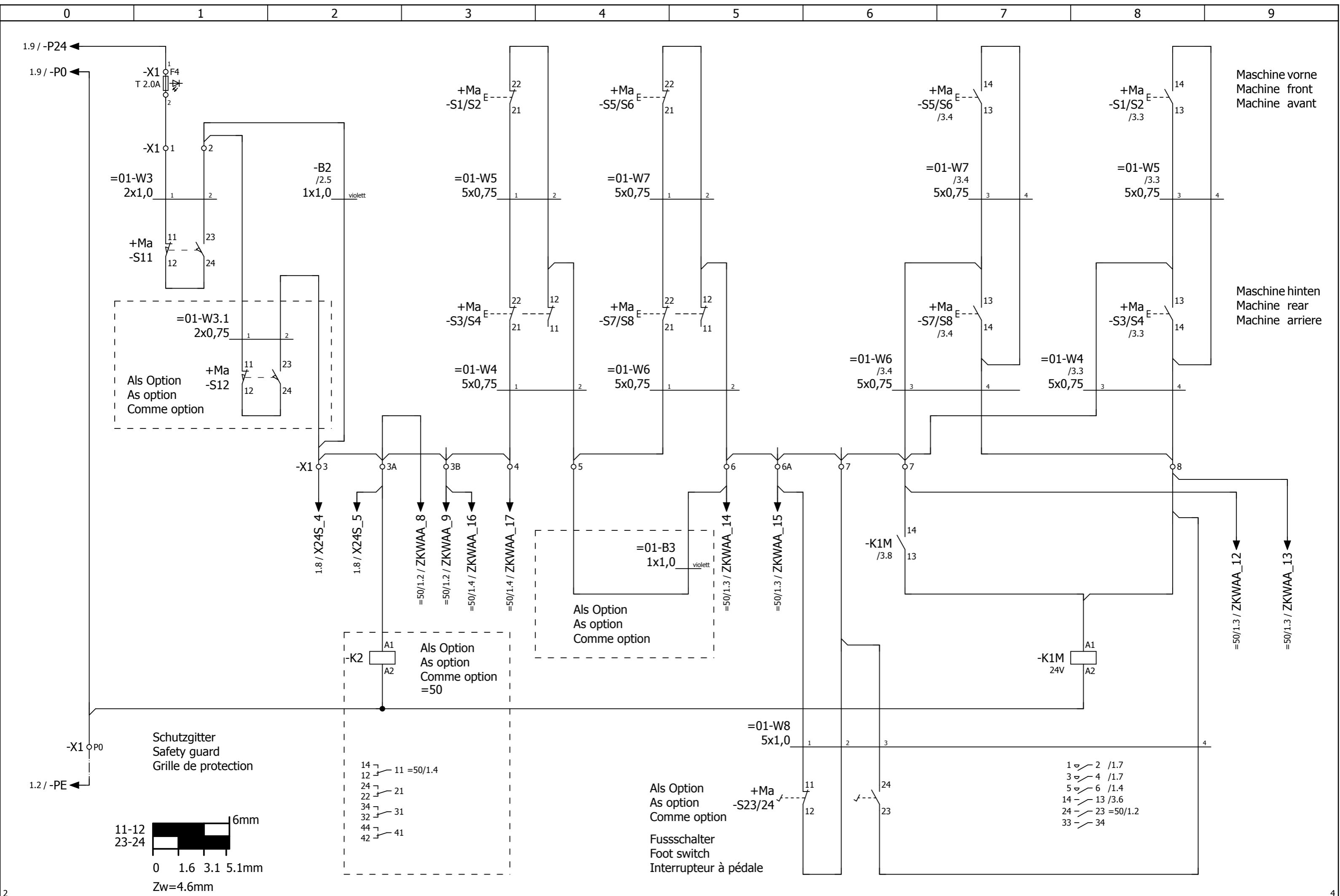

+Ma-X14F

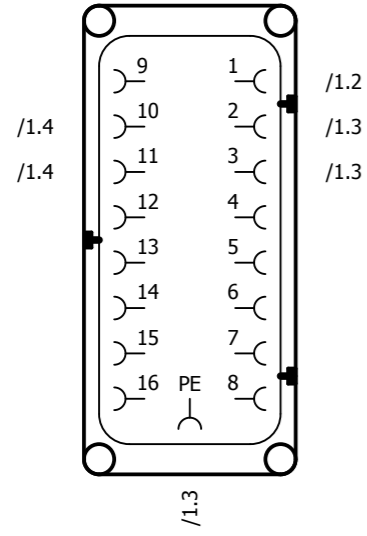

+Ma-X24F

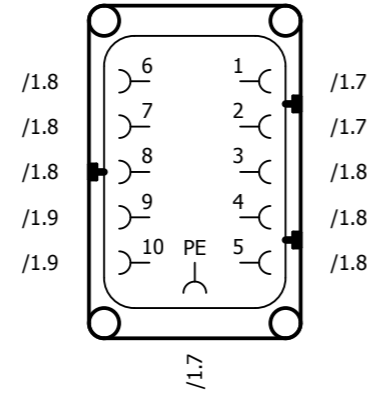

+Ma-X28M

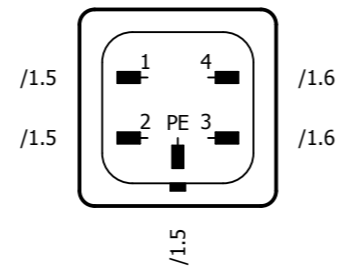

+Ma-X14F =

+Ma-X24F =

+Ma-X28M =

			Date	19.04.2013
			Ed. by	Ryser_h
			Appr	
Modification	Date	Name	Original	

Page name	Stecker
	Plug
	Connecteur

Plant designation	SFT*62V*
Drawing number	505135a

Machine number	== S1
	= 01
Commission number	+ 1
Total Pg 17	Page 4

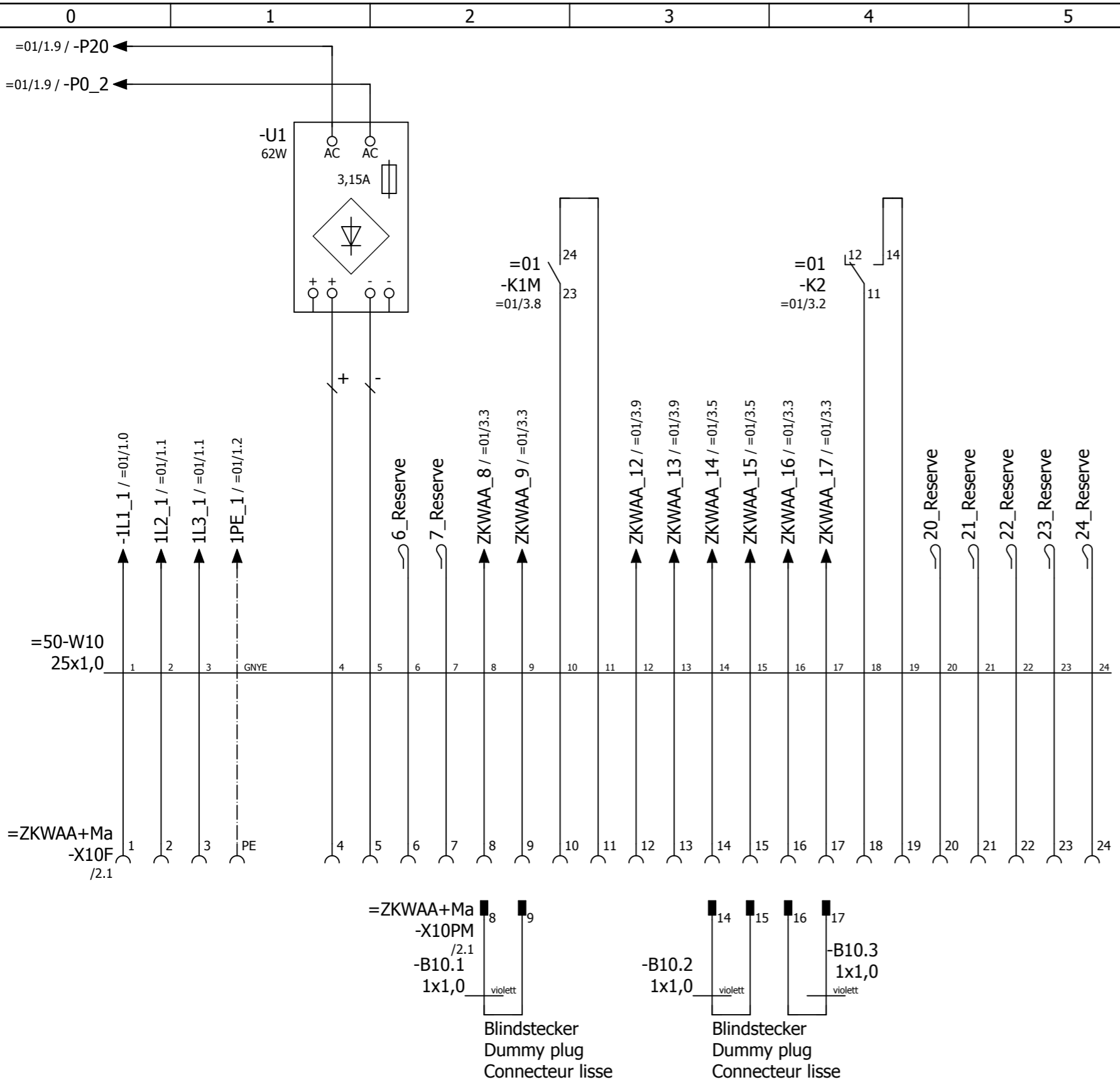

Pin	ROB	Ext.	Bemerkung Remark Remarque	d/e/f
1	→	→	Netz Mains Reseau	
2	→	→	Netz Mains Reseau	
3	→	→	Netz Mains Reseau	
4	→	→	24VDC Verbundbetrieb Compound operation Opération compound	
5	→	→	0VDC Verbundbetrieb Compound operation Opération compound	
6			Reserve Spare Reservé	
7			Reserve Spare Reservé	
8	←	←	Sicherheitskreis von Extern Emergency circuit from external Circuit sécurité d'externe	
9	←	←	Sicherheitskreis von Extern Emergency circuit from external Circuit sécurité d'externe	
10	→	→	Ein / Aus nach Extern ON / OFF to external ENCL. / DECL. vers l'externe	
11	→	→	Ein / Aus nach Extern ON / OFF to external ENCL. / DECL. vers l'externe	
12	←	←	Linie Ein von Extern Installation On from Instal. en circuit de l'ext	
13	←	←	Linie Ein von Extern Installation On from Instal. en circuit de l'ext	
14	←	←	Linie Aus von Extern Installation Off from Instal. hors circuit de l'externe	
15	←	←	Linie Aus von Extern Installation Off from Instal. hors circuit de l'externe	
16	←	←	Störmeldung Fault indication Signalisation de défauts	
17	←	←	Störmeldung Fault indication Signalisation de défauts	
18	→	→	Sicherheitskreis nach Extern Emergency circuit to external Circuit sécurité vers l'externe	
19	→	→	Sicherheitskreis nach Extern Emergency circuit to external Circuit sécurité vers l'externe	
20			Reserve Spare Reservé	
21			Reserve Spare Reservé	
22			Reserve Spare Reservé	
23			Reserve Spare Reservé	
24			Reserve Spare Reservé	
PE	↔	↔	Erde ground terre	

Interface ZKWA60*
 Interface ZKWA60*
 D'interface ZKWA60*

Schema 501630*/505124*
 scheme 501639*/505123*
 schéma



Modification	Date	Name	Original

Date	13.01.2014
Ed. by	Ryser_h
Appr	
Page name	Interface ZKWA60* Interface ZKWA60* D'interface ZKWA60*

Plant designation	SFT*62V*
Drawing number	505135a

Machine number	== S1
	= 50
Commission number	+ 1
Total Pg 17	Page 1

=ZKWAA+Ma-X10F

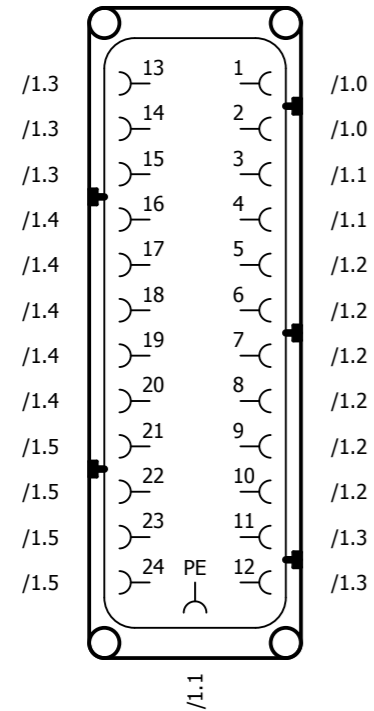

=ZKWAA+Ma-X10PM

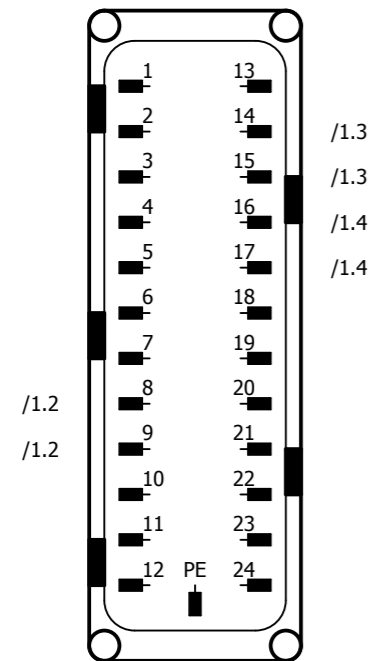

=ZKWAA+Ma-X10F =

=ZKWAA+Ma-X10PM =

				Date	05.03.2013
				Ed. by	saladi_r
				Appr	
Modification	Date	Name	Original		

Page name	Stecker
Plug	
Connecteur	

Plant designation	SFT*62V*
Drawing number	505135a

Machine number	== S1
	= 50
Commission number	+ 1
Total Pg 17	Page 2

Klemmenaufreihplan/ Terminal line-up diagram/ Plan des bornes associables/

Klemmenleiste
Terminal strip
Bornier

==S1=01+1-X1

Klemme Terminal Borne	Brücke Jumper Pont	Artikelnummer Part number Numéro d'article	Seite Page Page	Klemmenzubehör Terminal accessories Accessoire de borne	Abschlussplatte End plate Flasque de fin	Brücke Jumper Pont	Endklammer für TS35 End piece Piece finale
F4	o	52128	==S1=01+1/3	8935	52130		52131
F2	o	52127	==S1=01+1/1	11053			
F1	o	52127	==S1=01+1/1	11053	52130		
L1	o	52120	==S1=01+1/1				
L2	o	52120	==S1=01+1/1				
L3	o	52120	==S1=01+1/1				
PE	o	52122	==S1=01+1/1				
1L1	o	52120	==S1=01+1/1				
1L2	o	52120	==S1=01+1/1				
PE	o	52122	==S1=01+1/1				
2L1	o	52120	==S1=01+1/1				
2L2	o	52120	==S1=01+1/1				
A	o	52120	==S1=01+1/2				
B	o	52120	==S1=01+1/2				
PE	o	52122	==S1=01+1/2				
56	o	52120	==S1=01+1/1				
57	o	52120	==S1=01+1/1				
P0	o	52120	==S1=01+1/3				
1	o	52120	==S1=01+1/3				
2	o	52120	==S1=01+1/3				
3	o ●	52120	==S1=01+1/3				
3A	o ●	52120	==S1=01+1/3				
3B	o ●	52120	==S1=01+1/3				
4	o ●	52120	==S1=01+1/3				

5	o	52120	==S1=01+1/3				
6	o ●	52120	==S1=01+1/3				
6A	o ●	52120	==S1=01+1/3				
7	o ●	52120	==S1=01+1/3				
7	o ●	52120	==S1=01+1/3				
8	o	52120	==S1=01+1/3			52124	52131

Steckerübersicht - Plug overview - Aperçu des connecteurs -

Steckerbezeichnung Plug designation Désignation de connecteur	Artikelnummer Part number Numéro d'article	Normal Normal Normal	+	1	Seite / Spalte Page / column Page / Colonne
==S1=01+Ma-X14F	50023;51276	16	+	1	==S1=01+1/4.1
==S1=01+Ma-X24F	50022;50028	10	+	1	==S1=01+1/4.2
==S1=01+Ma-X28M	50314;51271	4	+	1	==S1=01+1/4.4
==S1=ZKWAA+Ma-X10F	53278;51283	24	+	1	==S1=50+1/2.1
==S1=ZKWAA+Ma-X10PM	53284;52426	24	+	1	==S1=50+1/2.1

Artikelstückliste / Parts list / Liste d'articles /

Betriebsmittelkennzeichen Device tag Désignation de composant	Art.-Nr.: Prt.-Nr.: Art.-ref.:	Beschreibung Description Description	Betriebsmittelkennzeichen Device tag Désignation de composant	Art.-Nr.: Prt.-Nr.: Art.-ref.:	Beschreibung Description Description
==S1=01+1-G1	11745	Einphasen-DC-Drehzahlregler Monoph. speed regulator Regulateur de vitesse monoph. Un=190-265VAC 50/60Hz	==S1=01+Ma-S1/S2	53998	Tastenschild schwarz mit O weiss Sign keys black with O white Inscription clés noir avec O blanc
==S1=01+1-G1	11432	Sicherung superflink Fuse super-quickacting Fusible a act. ultra rapide Gr=5x20	==S1=01+Ma-S1/S2	51200	Hilfskontaktblock 1S Contact component 1S Module de contacts auxiliaires
==S1=01+1-K1M	53436	Kleinleistungsschutz Contactor miniature Contacteur de petit calibre	==S1=01+Ma-S1/S2	51204	Hilfskontakt 1Ö Contact auxiliary 1O Contact auxiliaire 1O
==S1=01+1-K1M	53438	Hilfskontaktblock 2S Contact component 2S Module de contacts auxiliaires	==S1=01+Ma-S1/S2	53474	Schutzkappe ZBA 708 Cap, protective ZBA 708 Cache de protection ZBA 708 für 2 flache Tasten
==S1=01+1-K2	52101	Stecksockel Plug-in socket Socle enfichable	==S1=01+Ma-S3/S4	53428	Zweifachtaster 2 Push-button 2 Bouton-poussoir
==S1=01+1-K2	52103	Klein Steckrelais Plug-in relay miniature Petit relais enfichable	==S1=01+Ma-S3/S4	53997	Tastenschild weiss mit I schwarz Sign keys white with I black Inscription clés blanc avec I noir
==S1=01+1-K2	52146	Haltebügel zu NT52101 Clamp for NT52101 Cadre support pour NT52101	==S1=01+Ma-S3/S4	53998	Tastenschild schwarz mit O weiss Sign keys black with O white Inscription clés noir avec O blanc
==S1=01+1-T1	50040	Einphasentransformator Single-phase transformer Autotransformateur monophasé	==S1=01+Ma-S3/S4	51200	Hilfskontaktblock 1S Contact component 1S Module de contacts auxiliaires
==S1=01+1-Z2	50434	Netzfilter, einpolig Line filter, single-pole Filtre de réseau, unipolaire	==S1=01+Ma-S3/S4	51204	Hilfskontakt 1Ö Contact auxiliary 1O Contact auxiliaire 1O
==S1=01+2-R2	51373	Potentiometer Potentiometer Potentiometre	==S1=01+Ma-S3/S4	53474	Schutzkappe ZBA 708 Cap, protective ZBA 708 Cache de protection ZBA 708 für 2 flache Tasten
==S1=01+2-R2	54403	Potentiometerknopf Turning knob Bouton tournant Zählwerk 0-15 digita d=6,3mm	==S1=01+Ma-S5/S6	53428	Zweifachtaster 2 Push-button 2 Bouton-poussoir
==S1=01+Ma-M1	50348	DC-Getr.-Motor m.Flansch Gear motor with flange Moto-reducteur avec flasque	==S1=01+Ma-S5/S6	53997	Tastenschild weiss mit I schwarz Sign keys white with I black Inscription clés blanc avec I noir
==S1=01+Ma-S1/S2	53428	Zweifachtaster 2 Push-button 2 Bouton-poussoir	==S1=01+Ma-S5/S6	53998	Tastenschild schwarz mit O weiss Sign keys black with O white Inscription clés noir avec O blanc
==S1=01+Ma-S1/S2	53997	Tastenschild weiss mit I schwarz Sign keys white with I black Inscription clés blanc avec I noir	==S1=01+Ma-S5/S6	51200	Hilfskontaktblock 1S Contact component 1S Module de contacts auxiliaires

0

1

2

3

4

5

6

7

8

9

ROB_F01_003_V1

Artikelstückliste / Parts list / Liste d'articles /

Betriebsmittelkennzeichen Device tag Désignation de composant	Art.-Nr.: Prt.-Nr.: Art.-ref.:	Beschreibung Description Description
==S1=01+Ma-S5/S6	51204	Hilfskontakt 1Ö Contact auxiliary 1O Contact auxiliaire 1O
==S1=01+Ma-S5/S6	53474	Schutzkappe ZBA 708 Cap, protective ZBA 708 Cache de protection ZBA 708
==S1=01+Ma-S7/S8	53428	Zweifachtaster 2 Push-button 2 Bouton-poussoir
==S1=01+Ma-S7/S8	53997	Tastenschild weiss mit I schwarz Sign keys white with I black Inscription clés blanc avec I noir
==S1=01+Ma-S7/S8	53998	Tastenschild schwarz mit O weiss Sign keys black with O white Inscription clés noir avec O blanc
==S1=01+Ma-S7/S8	51200	Hilfskontaktblock 1S Contact component 1S Module de contacts auxiliaires
==S1=01+Ma-S7/S8	51204	Hilfskontakt 1Ö Contact auxiliary 1O Contact auxiliaire 1O
==S1=01+Ma-S7/S8	53474	Schutzkappe ZBA 708 Cap, protective ZBA 708 Cache de protection ZBA 708
==S1=01+Ma-S11	11965a	Klein-Grenztaster 1Ö + 1S Limit switch 1Ö + 1S Commutateur de fin de course 1Ö + 1S
==S1=01+Ma-S12	11965a	Klein-Grenztaster 1Ö + 1S Limit switch 1Ö + 1S Commutateur de fin de course 1Ö + 1S
==S1=01+Ma-S23/24	11975	Fussschalter Foot switch Interrupteur à pédale
==S1=01+Ma-X14F	50023	Steckdoseneinsatz 16p+PE Socket insert 16p+PE Insert de prise femelle 16p+PE
==S1=01+Ma-X14F	51276	Tuellengehaeuse 16p/M25s Gromment housing 16p Boite de passe-cable 16p
==S1=01+Ma-X24F	50022	Steckdoseneinsatz 10p+PE Socket insert 10p+PE Insert de prise femelle 10p+PE

Betriebsmittelkennzeichen Device tag Désignation de composant	Art.-Nr.: Prt.-Nr.: Art.-ref.:	Beschreibung Description Description
==S1=01+Ma-X24F	50028	Anbaugehaeuse 10p Attached housing 10p Boite adaptable 10p
==S1=01+Ma-X28M	50314	Steckereinsatz 4p+PE Plug insert 4p+PE Insert de prise male 4p+PE
==S1=01+Ma-X28M	51271	Tuellengehaeuse M20s Gromment housing M20s Boite de passe-cable M20s
==S1=50+1-U1	50085	Stromversorgung 1-phasig Power supply 1Ph Alimentation en courant pour 1Ph
==S1=50+1-U1	10538	Sicherung traeg Fuse slow Fusible a act. ret.
==S1=ZKWAA+Ma-X10F	53278	Steckereinsatz 24Bu. Plug insert 24Bu. Insert de prise male 24Bu.
==S1=ZKWAA+Ma-X10F	51283	Tuellengehaeuse 24p/M32s Gromment housing 24p/M32s Boite de passe-cable 24p/M32s
==S1=ZKWAA+Ma-X10PM	53284	Steckereinsatz 24St Plug insert 24Bu. Prise 24pole
==S1=ZKWAA+Ma-X10PM	52426	Sockelgehaeuse 24p/M25 mit Deckel Base housing 24p/M25 Boite de socle 24p/M25

+CABLE/1

RONDO
Dough-how & more.

Modification	Date	Name	Original
	13.01.2014		
	Ed. by	Ryser_h	
	Appr		

Page name
Artikelstückliste
Parts list
Liste des composants électriques

Plant designation
SFT*62V*
Drawing number
505135a

Machine number
Commission number

== DATA
= DOC
+ COMPONENT

Total Pg 17

Page 2

Kabelplan - Cable diagram - Plan de câblage -

Cable name ==S1=01+1-B1		Cross-section 1,0 mm²		Part number 13260		
Cable type TT		Cable length		Bemerkung Remark Remarque		
No. of conductors 1						
Seite / Spalte Page / column Page / Colonne	Anschluss Connection point Raccordement	Zielbezeichnung von Target designation from Désignation de destination de	← Ader Conductor Conducteur →	Zielbezeichnung nach Target designation to Désignation de destination vers	Anschluss Connection point Raccordement	Seite / Spalte Page / column Page / Colonne
/2.4	2	=01 +1 -G1	← violett →	=01 +1 -G1	4	/2.4

Cable name ==S1=01+1-B1.1		Cross-section 1,0 mm²		Part number 13260		
Cable type TT		Cable length		Bemerkung Brücke Remark Jumper Remarque		
No. of conductors 1						
Seite / Spalte Page / column Page / Colonne	Anschluss Connection point Raccordement	Zielbezeichnung von Target designation from Désignation de destination de	← Ader Conductor Conducteur →	Zielbezeichnung nach Target designation to Désignation de destination vers	Anschluss Connection point Raccordement	Seite / Spalte Page / column Page / Colonne
/1.8	7	=01 +Ma -X24F	← violett →	=01 +Ma -X24F	9	/1.9

Cable name ==S1=01+1-B1.2		Cross-section 1,0 mm²		Part number 13260		
Cable type TT		Cable length		Bemerkung Brücke Remark Jumper Remarque		
No. of conductors 1						
Seite / Spalte Page / column Page / Colonne	Anschluss Connection point Raccordement	Zielbezeichnung von Target designation from Désignation de destination de	← Ader Conductor Conducteur →	Zielbezeichnung nach Target designation to Désignation de destination vers	Anschluss Connection point Raccordement	Seite / Spalte Page / column Page / Colonne
/1.8	8	=01 +Ma -X24F	← violett →	=01 +Ma -X24F	10	/1.9

Cable name ==S1=01+1-B2		Cross-section 1,0 mm²		Part number 13260;13260		
Cable type TT		Cable length		Bemerkung Remark Remarque		
No. of conductors 1						
Seite / Spalte Page / column Page / Colonne	Anschluss Connection point Raccordement	Zielbezeichnung von Target designation from Désignation de destination de	← Ader Conductor Conducteur →	Zielbezeichnung nach Target designation to Désignation de destination vers	Anschluss Connection point Raccordement	Seite / Spalte Page / column Page / Colonne
/2.5	16	=01 +1 -G1	← violett →	=01 +1 -G1	17	/2.5
/3.1	2	=01 +1 -X1	← violett →	=01 +1 -X1	3	/3.2

Cable name ==S1=01+1-B3		Cross-section 1,0 mm²		Part number 13260		
Cable type TT		Cable length		Bemerkung Remark Remarque		
No. of conductors 1						
Seite / Spalte Page / column Page / Colonne	Anschluss Connection point Raccordement	Zielbezeichnung von Target designation from Désignation de destination de	← Ader Conductor Conducteur →	Zielbezeichnung nach Target designation to Désignation de destination vers	Anschluss Connection point Raccordement	Seite / Spalte Page / column Page / Colonne
/3.4	5	=01 +1 -X1	← violett →	=01 +1 -X1	6	/3.5

Cable name ==S1=01+1-W1_EU		Cross-section 2,5 mm²		Part number 13990		
Cable type PUR		Cable length		Bemerkung Remark Remarque		
No. of conductors 4		138612T04				
Seite / Spalte Page / column Page / Colonne	Anschluss Connection point Raccordement	Zielbezeichnung von Target designation from Désignation de destination de	← Ader Conductor Conducteur →	Zielbezeichnung nach Target designation to Désignation de destination vers	Anschluss Connection point Raccordement	Seite / Spalte Page / column Page / Colonne
/1.0	L1	=01 +1 -X1	← BN →			/1.0
/1.1	L2	=01 +1 -X1	← SW →			/1.1
/1.1	L3	=01 +1 -X1	← GR →			/1.1

/1.1	PE	=01 +1 -X1	← GNYE →			/1.1
------	----	------------	----------	--	--	------

Cable name ==S1=01+1-W1_USA		Cross-section 2,08 mm²		Part number 13555		
Cable type PUR		Cable length		Bemerkung Remark Remarque		
No. of conductors 4		108232T02				
Seite / Spalte Page / column Page / Colonne	Anschluss Connection point Raccordement	Zielbezeichnung von Target designation from Désignation de destination de	← Ader Conductor Conducteur →	Zielbezeichnung nach Target designation to Désignation de destination vers	Anschluss Connection point Raccordement	Seite / Spalte Page / column Page / Colonne
/1.0	L1	=01 +1 -X1	← SW →			/1.0
/1.1	L2	=01 +1 -X1	← WS →			/1.1
/1.1	L3	=01 +1 -X1	← RT →			/1.1
/1.1	PE	=01 +1 -X1	← GN →			/1.2

Cable name ==S1=01+1-W2		Cross-section 1,0 mm²		Part number 12752		
Cable type TT-flex NK JZ CY		Cable length		Bemerkung Remark Remarque		
No. of conductors 3		123370T03 oder 123370T04				
Seite / Spalte Page / column Page / Colonne	Anschluss Connection point Raccordement	Zielbezeichnung von Target designation from Désignation de destination de	← Ader Conductor Conducteur →	Zielbezeichnung nach Target designation to Désignation de destination vers	Anschluss Connection point Raccordement	Seite / Spalte Page / column Page / Colonne
/2.3	A	=01 +1 -X1	← 1 →	=01 +Ma -M1	A2	/2.3
/2.3	B	=01 +1 -X1	← 2 →	=01 +Ma -M1	A1	/2.3
/2.3	PE	=01 +1 -X1	← GNYE →	=01 +Ma -M1	PE	/2.3

Cable name ==S1=01+1-W3		Cross-section 1,0 mm²		Part number 13070		
Cable type K-M OZ		Cable length		Bemerkung Remark Remarque		
No. of conductors 2		106633				
Seite / Spalte Page / column Page / Colonne	Anschluss Connection point Raccordement	Zielbezeichnung von Target designation from Désignation de destination de	← Ader Conductor Conducteur →	Zielbezeichnung nach Target designation to Désignation de destination vers	Anschluss Connection point Raccordement	Seite / Spalte Page / column Page / Colonne
/3.1	1	=01 +1 -X1	← 1 →	=01 +Ma -S11	11	/3.1
/3.1	2	=01 +1 -X1	← 2 →	=01 +Ma -S11	23	/3.1

Cable name ==S1=01+1-W3.1		Cross-section 0,75 mm²		Part number 13069		
Cable type K-M OZ		Cable length		Bemerkung Remark Remarque		
No. of conductors 2		106633				
Seite / Spalte Page / column Page / Colonne	Anschluss Connection point Raccordement	Zielbezeichnung von Target designation from Désignation de destination de	← Ader Conductor Conducteur →	Zielbezeichnung nach Target designation to Désignation de destination vers	Anschluss Connection point Raccordement	Seite / Spalte Page / column Page / Colonne
/3.1	2	=01 +1 -X1	← 1 →	=01 +Ma -S12	11	/3.1
/3.2	3	=01 +1 -X1	← 2 →	=01 +Ma -S12	23	/3.2

+COMPONENT/2



Date	04.12.2014
Ed. by	ryser_h
Appr	
Modification	Date
Name	Original

Page name
Kabelplan
Cable diagram
Représentation des câbles

Plant designation
SFT*62V*
Drawing number
505135a

Machine number
Commission number
Total Pg 17 Page 1

Kabelplan - Cable diagram - Plan de câblage -

Cable name ==S1=01+1-W4			Cross-section 0,75 mm²	Part number 13448		
Cable type K-M JZ			Cable length			
No. of conductors 5			Bemerkung Remark 124071T02 Schalterkabel hinten Remarque			
Seite / Spalte Page / column Page / Colonne	Anschluss Connection point Raccordement	Zielbezeichnung von Target designation from Désignation de destination de	Ader Conductor Conducteur	Zielbezeichnung nach Target designation to Désignation de destination vers	Anschluss Connection point Raccordement	Seite / Spalte Page / column Page / Colonne
/3.3	4	=01 +1 -X1	← 1 →	=01 +Ma -S3/S4	21	/3.3
/3.4	5	=01 +1 -X1	← 2 →	=01 +Ma -S3/S4	12	/3.4
/3.6	7	=01 +1 -X1	← 3 →	=01 +Ma -S3/S4	13	/3.8
/3.8	8	=01 +1 -X1	← 4 →	=01 +Ma -S3/S4	14	/3.8
			← GNYE →			

Cable name ==S1=01+1-W5			Cross-section 0,75 mm²	Part number 13448		
Cable type K-M JZ			Cable length			
No. of conductors 5			Bemerkung Remark 124071T01 Schalterkabel vorne Remarque			
Seite / Spalte Page / column Page / Colonne	Anschluss Connection point Raccordement	Zielbezeichnung von Target designation from Désignation de destination de	Ader Conductor Conducteur	Zielbezeichnung nach Target designation to Désignation de destination vers	Anschluss Connection point Raccordement	Seite / Spalte Page / column Page / Colonne
/3.3	21	=01 +Ma -S1/S2	← 1 →	=01 +Ma -S3/S4	22	/3.3
/3.3	22	=01 +Ma -S1/S2	← 2 →	=01 +Ma -S3/S4	12	/3.4
/3.8	13	=01 +Ma -S1/S2	← 3 →	=01 +Ma -S3/S4	13	/3.8
/3.8	14	=01 +Ma -S1/S2	← 4 →	=01 +Ma -S3/S4	14	/3.8
			← GNYE →			

Cable name ==S1=01+1-W6			Cross-section 0,75 mm²	Part number 13448		
Cable type K-M JZ			Cable length			
No. of conductors 5			Bemerkung Remark 124071T04 Schalterkabel hinten Remarque			
Seite / Spalte Page / column Page / Colonne	Anschluss Connection point Raccordement	Zielbezeichnung von Target designation from Désignation de destination de	Ader Conductor Conducteur	Zielbezeichnung nach Target designation to Désignation de destination vers	Anschluss Connection point Raccordement	Seite / Spalte Page / column Page / Colonne
/3.4	5	=01 +1 -X1	← 1 →	=01 +Ma -S7/S8	21	/3.4
/3.5	6	=01 +1 -X1	← 2 →	=01 +Ma -S7/S8	12	/3.5
/3.6	7	=01 +1 -X1	← 3 →	=01 +Ma -S7/S8	13	/3.7
/3.8	8	=01 +1 -X1	← 4 →	=01 +Ma -S7/S8	14	/3.7
			← GNYE →			

Cable name ==S1=01+1-W7			Cross-section 0,75 mm²	Part number 13448		
Cable type K-M JZ			Cable length			
No. of conductors 5			Bemerkung Remark 124071T01 Schalterkabel vorne Remarque			
Seite / Spalte Page / column Page / Colonne	Anschluss Connection point Raccordement	Zielbezeichnung von Target designation from Désignation de destination de	Ader Conductor Conducteur	Zielbezeichnung nach Target designation to Désignation de destination vers	Anschluss Connection point Raccordement	Seite / Spalte Page / column Page / Colonne
/3.4	21	=01 +Ma -S5/S6	← 1 →	=01 +Ma -S7/S8	22	/3.4

/3.4	22	=01 +Ma -S5/S6	← 2 →	=01 +Ma -S7/S8	12	/3.5
/3.7	13	=01 +Ma -S5/S6	← 3 →	=01 +Ma -S7/S8	13	/3.7
/3.7	14	=01 +Ma -S5/S6	← 4 →	=01 +Ma -S7/S8	14	/3.7
			← GNYE →			

Cable name ==S1=01+1-W8			Cross-section 1,0 mm²	Part number 13009		
Cable type K-M JZ			Cable length			
No. of conductors 5			Bemerkung Remark Remarque			
Seite / Spalte Page / column Page / Colonne	Anschluss Connection point Raccordement	Zielbezeichnung von Target designation from Désignation de destination de	Ader Conductor Conducteur	Zielbezeichnung nach Target designation to Désignation de destination vers	Anschluss Connection point Raccordement	Seite / Spalte Page / column Page / Colonne
/3.5	6A	=01 +1 -X1	← 1 →	=01 +Ma -S23/24	11	/3.6
/3.6	7	=01 +1 -X1	← 2 →	=01 +Ma -S23/24	12	/3.6
/3.6	7	=01 +1 -X1	← 3 →	=01 +Ma -S23/24	24	/3.6
/3.8	8	=01 +1 -X1	← 4 →	=01 +Ma -S23/24	23	/3.6
			← GNYE →			

Cable name ==S1=01+1-W14			Cross-section 1,5 mm²	Part number 13370		
Cable type K-M JZ			Cable length			
No. of conductors 5			Bemerkung Remark 121223T02 121223T03 Remarque			
Seite / Spalte Page / column Page / Colonne	Anschluss Connection point Raccordement	Zielbezeichnung von Target designation from Désignation de destination de	Ader Conductor Conducteur	Zielbezeichnung nach Target designation to Désignation de destination vers	Anschluss Connection point Raccordement	Seite / Spalte Page / column Page / Colonne
/1.3	1L1	=01 +1 -X1	← 1 →	=01 +Ma -X14F	2	/1.3
/1.3	1L2	=01 +1 -X1	← 2 →	=01 +Ma -X14F	3	/1.3
/1.4	56	=01 +1 -X1	← 3 →	=01 +Ma -X14F	10	/1.4
/1.4	57	=01 +1 -X1	← 4 →	=01 +Ma -X14F	11	/1.4
/1.3	PE	=01 +1 -X1	← GNYE →	=01 +Ma -X14F	PE	/1.3

Cable name ==S1=01+1-W21			Cross-section mm²	Part number 13543		
Cable type			Cable length			
No. of conductors			Bemerkung Remark Remarque			
Seite / Spalte Page / column Page / Colonne	Anschluss Connection point Raccordement	Zielbezeichnung von Target designation from Désignation de destination de	Ader Conductor Conducteur	Zielbezeichnung nach Target designation to Désignation de destination vers	Anschluss Connection point Raccordement	Seite / Spalte Page / column Page / Colonne
/2.4	7	=01 +1 -G1	← WS →	=01 +2 -R2	1	/2.5
/2.5	9	=01 +1 -G1	← BN →	=01 +2 -R2	3	/2.5
/2.5	8	=01 +1 -G1	← GN →	=01 +2 -R2	2	/2.5
			← SH →			

Kabelplan - Cable diagram - Plan de câblage -

Cable name ==S1=01+1-W24		Cross-section 1,5 mm ²		Part number 13370	
Cable type K-M JZ		Cable length		Bemerkung Remark	
No. of conductors 5		Zielbezeichnung von Target designation from		Ader Conductor	
Seite / Spalte Page / column Page / Colonne	Anschluss Connection point Raccordement	Zielbezeichnung nach Target designation to Désignation de destination vers	Anschluss Connection point Raccordement	Seite / Spalte Page / column Page / Colonne	
/1.7	2L1	=01 +1 -X1	1	/1.7	
/1.7	2L2	=01 +1 -X1	2	/1.7	
/3.2	3	=01 +1 -X1	4	/1.8	
/3.2	3A	=01 +1 -X1	5	/1.8	
/1.3	PE	=01 +1 -X1	PE	/1.7	

Cable name ==S1=50+1-W10		Cross-section 1,0 mm ²		Part number 13919	
Cable type K-M JZ		Cable length		Bemerkung Remark	
No. of conductors 25		Zielbezeichnung von Target designation from		Ader Conductor	
Seite / Spalte Page / column Page / Colonne	Anschluss Connection point Raccordement	Zielbezeichnung nach Target designation to Désignation de destination vers	Anschluss Connection point Raccordement	Seite / Spalte Page / column Page / Colonne	
=01/1.0	L1	=01 +1 -X1	1	/1.0	
=01/1.1	L2	=01 +1 -X1	2	/1.0	
=01/1.1	L3	=01 +1 -X1	3	/1.1	
/1.1	+	=50 +1 -U1	4	/1.1	
/1.2	-	=50 +1 -U1	5	/1.2	
/1.2		=50 +1 -6_Reserve	6	/1.2	
/1.2		=50 +1 -7_Reserve	7	/1.2	
=01/3.2	3A	=01 +1 -X1	8	/1.2	
=01/3.3	3B	=01 +1 -X1	9	/1.2	
/1.2	23	=01 +1 -K1M	10	/1.2	
/1.2	24	=01 +1 -K1M	11	/1.3	
=01/3.6	7	=01 +1 -X1	12	/1.3	
=01/3.8	8	=01 +1 -X1	13	/1.3	
=01/3.5	6	=01 +1 -X1	14	/1.3	
=01/3.5	6A	=01 +1 -X1	15	/1.3	
=01/3.3	3B	=01 +1 -X1	16	/1.4	
=01/3.3	4	=01 +1 -X1	17	/1.4	
/1.4	11	=01 +1 -K2	18	/1.4	
/1.4	14	=01 +1 -K2	19	/1.4	
/1.4		=50 +1 -20_Reserve	20	/1.4	
/1.5		=50 +1 -21_Reserve	21	/1.5	
/1.5		=50 +1 -22_Reserve	22	/1.5	
/1.5		=50 +1 -23_Reserve	23	/1.5	
/1.5		=50 +1 -24_Reserve	24	/1.5	
=01/1.1	PE	=01 +1 -X1	PE	/1.1	

Cable name ==S1=01+1-W28		Cross-section 1,5 mm ²		Part number 12752	
Cable type K-M JZ		Cable length		Bemerkung Remark	
No. of conductors 3		Zielbezeichnung von Target designation from		Ader Conductor	
Seite / Spalte Page / column Page / Colonne	Anschluss Connection point Raccordement	Zielbezeichnung nach Target designation to Désignation de destination vers	Anschluss Connection point Raccordement	Seite / Spalte Page / column Page / Colonne	
/1.4	56	=01 +1 -X1	3	/1.6	
/1.4	57	=01 +1 -X1	4	/1.6	
/1.3	PE	=01 +1 -X1	PE	/1.5	

Cable name ==S1=50+1-B10.1		Cross-section 1,0 mm ²		Part number 13260	
Cable type TT		Cable length		Bemerkung Remark	
No. of conductors 1		Zielbezeichnung von Target designation from		Ader Conductor	
Seite / Spalte Page / column Page / Colonne	Anschluss Connection point Raccordement	Zielbezeichnung nach Target designation to Désignation de destination vers	Anschluss Connection point Raccordement	Seite / Spalte Page / column Page / Colonne	
/1.2	8	=ZKWAA +Ma -X10PM	9	/1.2	

Cable name ==S1=50+1-B10.2		Cross-section 1,0 mm ²		Part number 13260	
Cable type TT		Cable length		Bemerkung Remark	
No. of conductors 1		Zielbezeichnung von Target designation from		Ader Conductor	
Seite / Spalte Page / column Page / Colonne	Anschluss Connection point Raccordement	Zielbezeichnung nach Target designation to Désignation de destination vers	Anschluss Connection point Raccordement	Seite / Spalte Page / column Page / Colonne	
/1.3	14	=ZKWAA +Ma -X10PM	15	/1.3	

Cable name ==S1=50+1-B10.3		Cross-section 1,0 mm ²		Part number 13260	
Cable type TT		Cable length		Bemerkung Remark	
No. of conductors 1		Zielbezeichnung von Target designation from		Ader Conductor	
Seite / Spalte Page / column Page / Colonne	Anschluss Connection point Raccordement	Zielbezeichnung nach Target designation to Désignation de destination vers	Anschluss Connection point Raccordement	Seite / Spalte Page / column Page / Colonne	
/1.4	16	=ZKWAA +Ma -X10PM	17	/1.4	



Date	04.12.2014
Ed. by	ryser_h
Appr	
Original	
Modification	Date Name

Page name
Kabelplan
Cable diagram
Représentation des câbles

Plant designation
SFT*62V*
Drawing number
505135a

Machine number
Commission number
Total Pg 17 Page 3

