

BM2NT Dough Divider



BM2NT

- Dough divider, bench mounted
- Weight range from 50 – 300 grams
- Unit is supplied with OMAH026R0- Cone (Diameter 65mm, weight range 210 / 250 grams)
- Dough hopper capacity 30kg
- Output 700 – 1200 pieces per hour
- Maximum weight variance 10%

ACCESSORIES

- OMSU440 - Painted stand
- OMAC210R0 - Set of 4 wheels (2 with brakes)
- OMAH021R0 - Cone (Diameter 40mm, weight range 60 / 100 grams)
- OMAH022R0 - Cone (Diameter 45mm, weight range 90 / 130 grams)
- OMAH023R0 - Cone (Diameter 50mm, weight range 120 / 160 grams)
- OMAH024R0 - Cone (Diameter 55mm, weight range 150 / 190 grams)
- OMAH025R0 - Cone (Diameter 60mm, weight range 180 / 220 grams)
- OMAH027R0 - Cone (Diameter 35mm, weight range 50 / 70 grams)
- OMAH044R0 - Cone (Diameter 70mm, weight range 240 / 300 grams)

Also Available

- BM2AS - Dough Divider & Rounder
- AST - Dough Rounder



BM2NT

Dough Divider

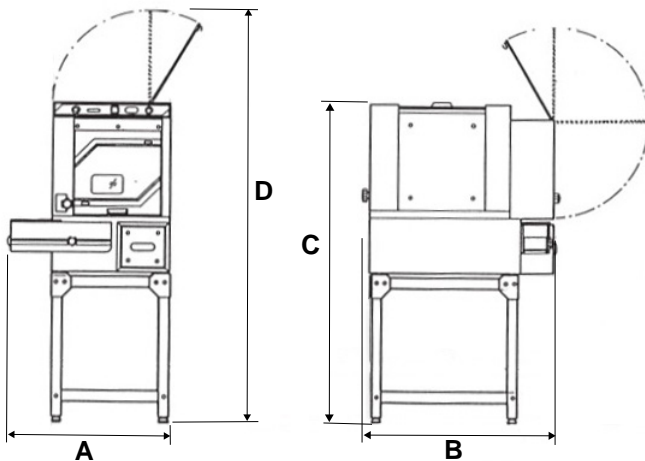

BM2NT

SPECIFICATIONS

External Dimensions

Width (A)	475mm
Depth (B)	765mm
Height (C)	740mm
Height (D)	1155mm

Electrical Requirements

400V, 3P+N+E, 50Hz, 0.48kW

Nett Weight

98kg

moffat.com.au

moffat.co.nz

Australia

moffat.com.au

Moffat Pty Limited

Victoria/Tasmania

740 Springvale Road

Mulgrave, Victoria 3170

Telephone +613-9518 3888

Facsimile +613-9518 3833

vsales@moffat.com.au

New South Wales

Telephone +612-8833 4111

nswsales@moffat.com.au

South Australia

Telephone +613-9518 3888

vsales@moffat.com.au

Queensland

Telephone +617-3630 8600

qldsales@moffat.com.au

Western Australia

Telephone +618-9413 2400

wasales@moffat.com.au

New Zealand

moffat.co.nz

Moffat Limited

Rolleston

45 Illinois Drive

Izone Business Hub

Rolleston 7675

Telephone +64 3-983 6600

Facsimile +64 3-983 6660

sales@moffat.co.nz

Auckland

Telephone +64 9-574 3150

sales@moffat.co.nz



In line with policy to continually develop and improve its products, Moffat Limited reserves the right to change specifications and design without notice. This specification sheet is meant for commercial purpose only. For technical documentation please refer to our service manuals.

© Copyright Moffat Ltd
ANO.3.24