

Varimixer

# AR200

**STRONG AND EFFECTIVE** The powerful motors have the capacity to handle large quantities of heavy ingredients.

**HYGIENIC AND EASY TO CLEAN** All surfaces and accessories are made of stainless steel, and the design ensures the best possible hygiene and very easy cleaning. Varimixer AR200 can be washed in accordance with the IP53 standard, and can be upgraded to either a marine version or IP54 cleaning, with a waterproof stainless steel mixer head.

**VARIABLE SPEED CONTROL** The speed is variably controlled by a very rugged system of belts, rather than gears. This solution means that the mixer does not contain oil, thus avoiding the risk of oil spilling into the bowl.

**REMOVABLE SAFETY GUARD** The removable safety guard is made of CE-approved plastic and is easy to attach and dishwasher safe. Varimixer AR200 can also be fitted with a sealed stainless steel guard which protects against dust and splashing.

**AUTOMATIC FIXATION** The bowl is wheeled into place between the two bowl arms. Using the handle – or automatically by pressing a button – the bowl is lowered or raised and locked in place in a single movement.

**EASY BOWL HANDLING** Choose between bowl trolley for transport or an electric bowl lift, which handles transport to and from the machine and all bowl lifts. This also ensures good ergonomics during filling and emptying. Choose between several models.

**STAINLESS STEEL** An easy-to-clean design. The AR200 comes as standard with completely stainless steel frame.



## VARIMIXER AR200 OPTIONS – MODELS



Stainless steel



Marine version, stainless steel

## OPTIONS – CONTROL PANEL



VL-4 – Automatic speed regulatic | manual bowl lowering

## OPTIONS – IP54



Waterproof planetary head, stainless steel, IP54



Double chimney, stainless steel, IP54

## OPTIONS – SAFETY GUARDS



Removable safety guard in plastic. CE-certified

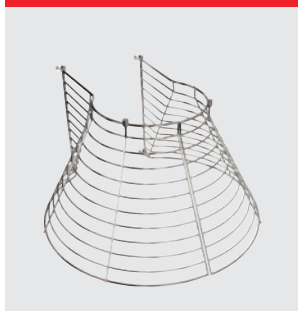

Removable safety guard in stainless steel. Not CE-certified

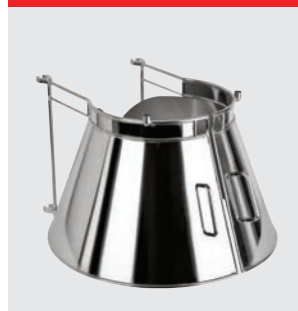

Removable splash guard in stainless steel. CE-certified

**VARIMIXER AR200 STANDARD TOOLS - A-EQUIPMENT 200L**



Double center reinforced whip with double pin in stainless steel and bowl 200 liter in stainless steel.

**OPTION - TOOLS**



Whip with double pin, stainless steel



Wing whip with double pin, stainless steel



Beater with double pin, stainless steel



Automatic scraper, stainless steel. Nylon or teflon blade.



Bowl with bottom draining pipe, stainless steel



Tool rack, 127 cm

**EQUIPMENT - TRANSPORTION**



Bowl truck



Megalift Inox



Wheels for bowl

### VARIMIXER AR200 STANDARD

Stainless steel  
1 bowl 200 liter in stainless steel  
1 double center reinforced whip with double pin stainless steel  
Removable safety guard in plastic – CE-certified  
Digital timer and emergency stop  
Voltage: 3 ph, 400V, 50 Hz with ground. 5.500 W

### VARIMIXER AR200 TECHNICAL DATA

Volume	200 l
Effect	5.500 W
Standard voltage*	400 V
Net weight	525 kg
H x W x L	2057x754x1301 mm
Variable speed	47 – 257 RPM
Phases	3 ph
IP code	IP53
IP code upgrade package	IP54

\*Other voltage power supply are available upon request in the range of 100 to 480 V.  
All standard and marine mixers are available in 50 and 60 Hz.

### VARIMIXER AR200 MARINE VERSION

Stainless steel execution, water cover at air ventilation, slottet free screws, full welded stainless steel knees, gasket at the rear plate, gasket at front panel and top cover. Complies with USPHS.

Voltage: 3 ph, 440V, 50-60 Hz with 0 and ground. 5.500 W  
3 ph, 480V, 50-60 Hz with 0 and ground. 5.500 W

### DIMENSIONS

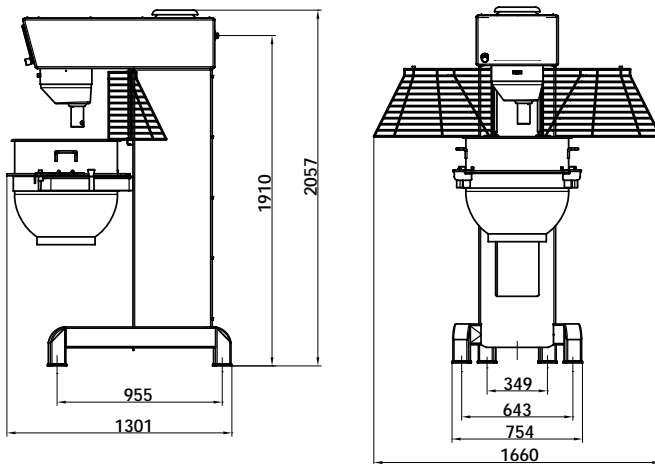

### CAPACITIES

Egg Whites	27 l
Whipped cream	120 l
Mayonnaise	160 l
Herb butter	150 kg
Mashed potatoes	140 kg
Muffins	120 kg
Layer cake base	50 kg
Meatball mix	150 kg
Icing	140 kg

### CERTIFICATIONS



# Varimixer

A/S Wodschow & Co  
Kirkebjerg Søpark 6  
DK-2605 Brøndby  
P: +45 4344 2288  
E: info@varimixer.com  
www.varimixer.com