

1PH-120-RA Industrial Divider 93

Product Features

- Volumetric suction divider with pre-rounder
- 80kg dough hopper (larger options available)
- Suitable for doughs between 50 - 65% AR
- Weight range 80 - 950 grams (other options available)
- Output 1400 - 2400 pieces per hour
- Weight and speed adjustment by hand wheels
- Piece counter fitted as standard
- Oiling system with minimal consumption
- PVC conveyor belt
- Stainless steel external panels
- Supplied on wheels



1PH-120

For more than 30 years Ciberpan has been developing state-of-the-art technology to create bakery equipment that enables producers to manufacture the best bakery products. Specialising in dough handling equipment, Ciberpan manufacture a range of dough dividers, intermediate provers and final moulders for the production of loaf bread as well as round and long bread rolls. Delivering compact footprints and unrivalled reliability in an affordable solution, Ciberpan equipment can transform your production environment.

1PH-120-RA Industrial Divider 93

Model 1PH-120

Dimensions

Width	1800mm
Depth	730mm
Height	1470mm

Electrical Requirements

400-415V, 3P+N+E, 50Hz, 1.9kW

Nett Weight 700kg

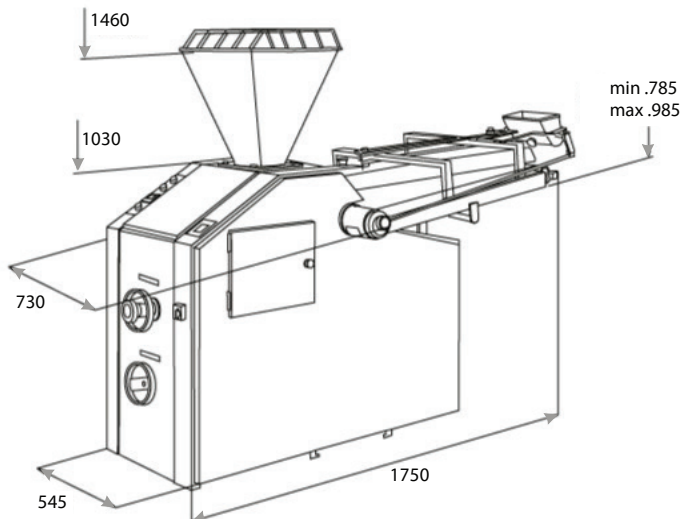

moffat.com.au
moffat.co.nz

Australia
moffat.com.au

Moffat Pty Limited
Victoria/Tasmania
740 Springvale Road
Mulgrave, Victoria 3170
Telephone +613-9518 3888
Facsimile +613-9518 3833
vsales@moffat.com.au

New South Wales
Telephone +612-8833 4111
nswsales@moffat.com.au

South Australia
Telephone +613-9518 3888
vsales@moffat.com.au

Queensland
Telephone +617-3630 8600
qldsales@moffat.com.au

Western Australia
Telephone +618-9413 2400
wasales@moffat.com.au

New Zealand
moffat.co.nz

Moffat Limited

Rolleston
45 Illinois Drive
Izone Business Hub
Rolleston 7675
Telephone +64 3-983 6600
Facsimile +64 3-983 6660
sales@moffat.co.nz

Auckland
Telephone +64 9-574 3150
sales@moffat.co.nz



In line with policy to continually develop and improve its products, Moffat Limited reserves the right to change specifications and design without notice. This specification sheet is meant for commercial purpose only. For technical documentation please refer to our service manuals.

© Copyright Moffat Ltd
ANC01.24

an Ali Group Company



The Spirit of Excellence