

CV1500

Dynamic Intermediate Prover

Product Features

- 7 pockets per tray
- 190 piece capacity (larger capacities available)
- Maximum dough piece weight 2500 grams
- Links up with 93 series divider
- Loading by means of infeed chute
- Unload with conveyor belt
- Integrated control for total production group (divider, intermediate prover and moulder)
- Full mechanical and electrical overload protections
- Fitted with UV light
- Flour duster on infeed with adjustable time
- Stainless steel external panels
- Assembly required



CV1500

For more than 30 years Ciberpan has been developing state-of-the-art technology to create bakery equipment that enables producers to manufacture the best bakery products. Specialising in dough handling equipment, Ciberpan manufacture a range of dough dividers, intermediate provers and final moulders for the production of loaf bread as well as round and long bread rolls. Delivering compact footprints and unrivalled reliability in an affordable solution, Ciberpan equipment can transform your production environment.



CV1500

Dynamic Intermediate Prover

Model CV1500

Dimensions

Width	2630mm
Depth	1630mm
Height	2570mm

Electrical Requirements

400-415V, 3P+N+E, 50Hz, 1.5kW

Nett Weight 850kg

moffat.com.au

moffat.co.nz

Australia

moffat.com.au

Moffat Pty Limited

Victoria/Tasmania

740 Springvale Road
Mulgrave, Victoria 3170
Telephone +613-9518 3888
Facsimile +613-9518 3833
vsales@moffat.com.au

New South Wales

Telephone +612-8833 4111
nswsales@moffat.com.au

South Australia

Telephone +613-9518 3888
vsales@moffat.com.au

Queensland

Telephone +617-3630 8600
qldsales@moffat.com.au

Western Australia

Telephone +618-9413 2400
wasales@moffat.com.au

New Zealand

moffat.co.nz

Moffat Limited

Rolleston

45 Illinois Drive
Izone Business Hub
Rolleston 7675
Telephone +64 3-983 6600
Facsimile +64 3-983 6660
sales@moffat.co.nz

Auckland

Telephone +64 9-574 3150
sales@moffat.co.nz

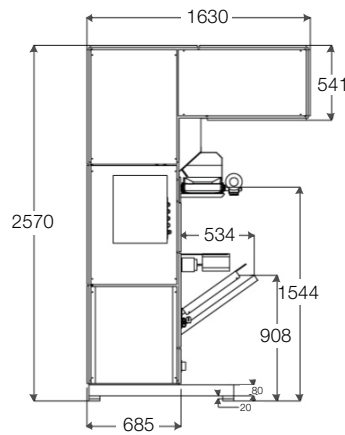
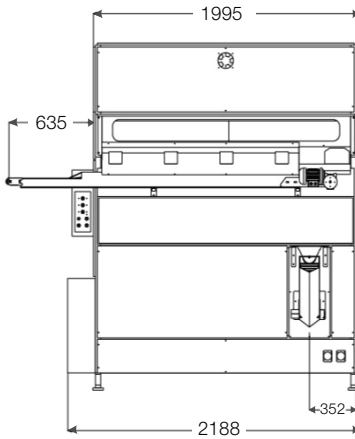

In line with policy to continually develop and improve its products, Moffat Limited reserves the right to change specifications and design without notice. This specification sheet is meant for commercial purpose only. For technical documentation please refer to our service manuals.

© Copyright Moffat Ltd
ANC01.21

an Ali Group Company



The Spirit of Excellence