

Technical data sheet for

E27M2 DOUBLE STACKED

Full Size Manual / Electric Convection Ovens

Double Stacked on a Stainless Steel Base Stand



Model E27M2/2C shown



E27M2/2 E27M2/2C

E27M2 ovens shall be Blue Seal electrically heated Turbofan convection ovens. The ovens shall have a one piece vitreous enamel oven chamber, stainless top and sides and safe touch vented easy clean drop down door. Ovens shall have capacity for two full size sheet pans. The ovens shall have 2.8kW heating elements. The ovens shall have a bi-directional single reversing fan system. The ovens shall be controlled by a mechanical thermostat with a range of 50-260°C, a 60 minute bake timer, and feature dual halogen oven lamps. Ovens shall be fitted with a 13A plug-in cordset. Ovens shall be double stacked using Double Stacking Kits DSK272831 (adjustable feet option) or DSK272831C (castor option). Units shall be supplied in 100% recyclable shipping packaging.

Double stack models are supplied as two individual ovens and a double stacking kit for field assembly.

E27M2/2 - Double stack with adjustable feet base stand

E27M2/2C - Double stack with castor base stand

DOUBLE STACK FEATURES

- Two full size ovens
- Compact 810mm width
- Full stainless steel base stand
- Full stainless steel oven spacer frame
- Adjustable feet or castor models
- Guard rail for bottom oven

OVEN FEATURES (each)

- 2 460mm x 660mm / 18" x 26" full size sheet pan capacity
- 2 400mm x 600mm tray capacity
- 115mm tray spacing
- Bi-directional reversing fan system
- 2.8kW heating
- 13A plug-in cordset fitted
- Vitreous enamel oven chamber
- Plug-in continuous oven door seal
- Safe-Touch vented drop down door
- Stay-Cool door handle
- Heavy-duty door hinges
- Easy clean door glass system
- Mechanical thermostat 50-260°C
- 60 minute timer with time up alarm
- Dual halogen oven lamps
- Dia. 180mm full stainless steel oven fan
- 2 oven wire racks supplied

E27M2/2 E27M2/2C Full Size Manual / Electric Convection Ovens Double Stacked on a Stainless Steel Base Stand

CONSTRUCTION - OVENS

Vitreous enameled fully welded oven chamber
Stainless steel front, sides and top exterior
Stainless steel oven fan baffle and oven vent
Removable 2 position chrome plated wire side racks
Oven racks chrome plated wire (2 supplied)
Stainless steel frame drop down hinged door
5mm thick door outer glass
5mm thick low energy loss door inner glass
Heavy-duty counterbalanced door hinges
Wear resistant powder coated welded door handle
Stainless steel control panel
Aluminised coated steel base and rear panels

CONSTRUCTION - DOUBLE STACKING KIT

All stainless steel construction
Welded 32mm and 38mm square tube front and rear frame
base stand
4 adjustable feet on E27M2/2
4 dia. 76mm swivel castors with 2 front castors dual wheel
and swivel lock on E27M2/2C
Stainless steel oven spacer frame
Stainless steel bottom oven vent extension

CONTROLS (each oven)

Power ON control panel indicator
Mechanical thermostat 50-260°C
Heating ON control panel indicator
Manual 60 minute timer
Time-Up control panel indicator and buzzer
Over-temperature safety cut-out

CLEANING

Stainless steel top and sides continuous exterior panel
Vitreous enameled oven chamber
Fully removable chrome plated oven side racks
Removable stainless steel oven fan baffle
Full stainless steel oven fan
Easy clean door system with hinge out door inner glass
(no tools required)
Removable plug-in oven door seal (no tools required)

SPECIFICATIONS

Electrical Requirements (each oven)
230-240V, 50Hz, 1P+N+E 3.0kW, 12A
13A cordset fitted

External Dimensions

Width 810mm
Height 1571mm (E27M2/2)
1653mm (E27M2/2C)
Depth 763mm

Oven Internal Dimensions (each oven)

Width 695mm
Height 305mm
Depth 470mm
Volume 0.10m³

Oven Rack Dimensions

Width 660mm
Depth 460mm

Nett Weight (double stack complete)
141kg

Packing Data (E27M2 ovens each)

77.8kg
0.55m³
Width 870mm
Height 755mm
Depth 835mm

Packing Data (Stacking Kit)

19kg (DSK272831 - adjustable feet)
22kg (DSK272831C - castor)
0.08m³
Width 590mm
Height 840mm
Depth 160mm

Supplied CKD for assembly on site

INSTALLATION CLEARANCES

Rear 25mm
LH Side 25mm
RH Side 25mm

CLEARANCE FROM SOURCES OF HEAT

A minimum distance of 300mm from the appliance sides is
required

Double Stacking Kits

For after market double stacking two E27M2 convection ovens
DSK272831 - Double stacking kit - adjustable feet
DSK272831C - Double stacking kit - castor



blue-seal.co.uk
turbofanoven.com

United Kingdom
Blue Seal Limited
Unit 67
Gravelly Business Park
Gravelly
Birmingham B24 8TQ
England
Telephone 0121-327 5575
Facsimile 0121-327 9711
sales@blue-seal.co.uk
www.blue-seal.co.uk

Australia
Moffat Pty Limited
740 Springvale Road
Mulgrave, Victoria 3170
Australia
Telephone 03-9518 3888
Facsimile 03-9518 3833
vsales@moffat.com.au
www.moffat.com.au

New Zealand
Moffat Limited
Christchurch
45 Illinois Drive
Izone Business Hub
Rolleston 7675
Telephone +64 3-983 6600
Facsimile +64 3-983 6660
sales@moffat.co.nz
www.moffat.co.nz



ISO9001
Quality
Management
Standard

Designed and manufactured by



ISO9001

All Turbofan products are designed and
manufactured by Moffat using the
internationally recognised ISO9001
quality management system, covering
design, manufacture and final inspection,
ensuring consistent high quality at all times.

In line with policy to continually develop
and improve its products, Moffat Limited
reserves the right to change specifications
and design without notice.



© Copyright Moffat Ltd
UK.TFN.S.1701

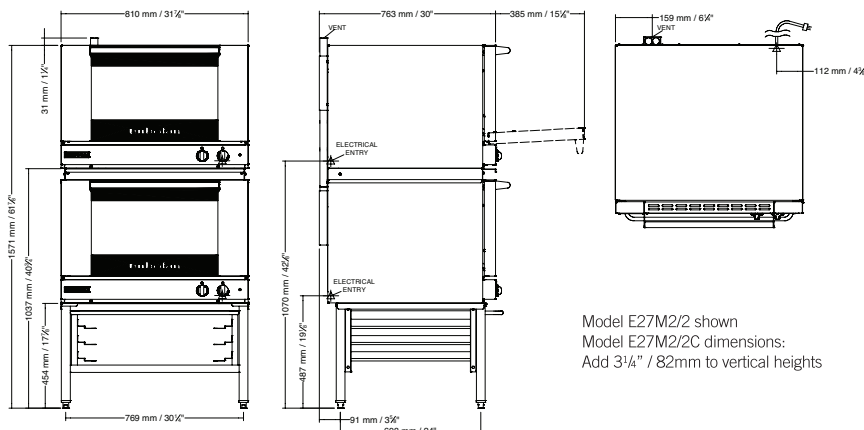

an Ali Group Company



The Spirit of Excellence