

ELECTRIC COOKTOPS 600mm

E514D-B, E514D-CB, E514D-LS, E514C-B, E514C-CB, E514C-LS, E514B-B, E514B-CB, E514B-LS

- Heavy-duty construction
- 2.4kW open radiant elements
- Optional hot plate elements
- 300mm and 600mm griddle plate options
- 3 models of base unit
- Rear rollers
- Stainless steel exterior
- Easy clean
- Easy service
- Fully modular



E514D-LS

Overall Construction

Cooktop

- Welded hob with 1.5mm 304 stainless steel bull nose
- Side panels 1.2mm 304 stainless steel
- Splashback 1.2mm 304 stainless steel
- Vitreous enamelled control panel
- 2.4kW open radiant elements in heavy-duty welded element frames
- Stainless steel spill trays
- Hot plate elements with machine finished 8mm steel plate (optional extra)
- 12mm thick mild steel griddle plates
- 2.5mm 304 stainless steel griddle splash guards
- Aluminised steel internal construction

Griddle sections are standard on RH side. Available on LH side to order.

Bench mount (supplied as -B model)

- Four 63mm dia. heavy-duty 1.2mm 304 stainless steel bench legs with adjustable feet
- Adjustable height 80mm – 105mm

Cabinet Base (supplied as -CB model)

- Fully modular for match suite finish
- Double skin 0.9mm 304 stainless steel interior and exterior
- Optional GN 1/1 4 position racking kit
- 63mm dia. heavy-duty 1.2mm 304 stainless steel legs with two adjustable feet at front and two rollers at rear

Leg Stand (supplied as -LS model)

- Fully modular for matched suite finish
- Framed top for connection to Cooktop
- 63mm dia. heavy-duty 1.2mm 304 stainless steel legs with two adjustable feet at front and two rollers at rear
- Fully modular framed stand shelf with 0.9mm 304 stainless steel finish
- Quick assembly design

Controls

- Large easy use control knob - heat resistant reinforced
- Easy view control settings on knob
- Radiant elements with energy regulator controls
- Hot Plate elements with energy regulator controls
- 50-320°C thermostat per 300mm griddle section
- Indicator lights for power and heating for each griddle control
- Power indicator lights for each element control

Cleaning and Servicing

- All models with easy clean stainless steel external finish
- Stainless steel spill trays
- Lift up element and griddle sections
- Access to all parts from front of unit

ELECTRIC COOKTOPS 600mm

E514D-B, E514D-CB, E514D-LS, E514C-B, E514C-CB, E514C-LS, E514B-B, E514B-CB, E514B-LS

Specifications

Cooktop

2.4 kW Open Radiant elements
2.0 kW Hot Plate elements
3.4 kW Griddle elements
(per 300mm griddle section)

Griddle Plate

300mm Griddle cooking surface
292mm x 475mm, 1387cm²
600mm Griddle cooking surface
592mm x 475mm, 2812cm²

Electrical requirements

E514D

9.6 kW, 400-415Vac, 50/60hz, 2P+N+E, 20A/phase

E514C

8.2 kW, 400-415Vac, 50/60hz, 2P+N+E,
20A/phase max

E514B

6.8 kW, 230-240Vac, 50/60hz, 2P+N+E, 14.2A/phase

Dimensions

Bench models

Width 600mm
Depth 812mm
Height 315mm
Incl. splashback 485mm

All models (excluding Bench model)

Width 600mm
Depth 812mm
Height 915mm
Incl. splashback 1085mm

Nett weight

Bench and Leg Stand models

74kg

Cabinet Base models

79kg

Packing data

Bench and Leg Stand models

0.37m³, 110kg
Width 645mm
Depth 870mm
Height 665mm

Cabinet Base models

0.70m³, 131kg
Width 870mm
Depth 645mm
Height 1255mm

Options

Adjustable feet at rear
Hot plate elements
(replace individual open radiant elements)
Ribbed griddle plates

E514-B

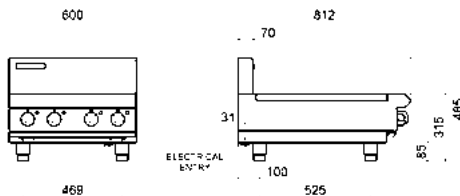

E514-LS

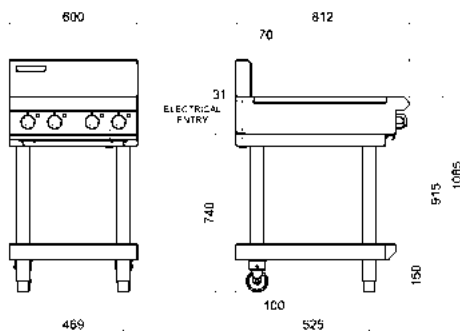

E514-CB

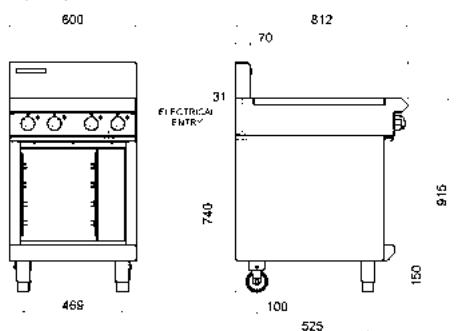

E514D

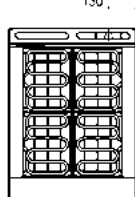

E514C

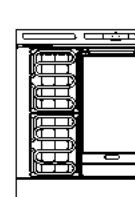

E514B

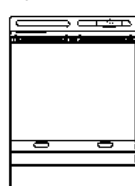

www.blue-seal.co.uk

United Kingdom
blue-seal.co.uk

Blue Seal Limited
Unit 67
Gravelly Business Park
Gravelly
Birmingham B24 8TQ
England
Telephone 0121-327 5575
Facsimile 0121-327 9711
sales@blue-seal.co.uk

Australia
moffat.com.au

Moffat Pty Limited
740 Springvale Road
Mulgrave
Victoria 3170
Australia
Telephone +613-9518 3888
Facsimile +613-9518 3833
vsales@moffat.com.au

New Zealand
moffat.co.nz

Moffat Limited
45 Illinois Drive
Izone Business Hub
Rolleston 7675
New Zealand
Telephone +64 3-983 6600
Facsimile +64 3-983 6660
sales@moffat.co.nz

International
moffat.com
international@moffat.co.nz



ISO9001
Quality
Management
Standard

Designed and manufactured by



ISO9001

All Blue Seal products are designed and manufactured by Moffat using the internationally recognised ISO9001 quality management system, covering design, manufacture and final inspection, ensuring consistent high quality at all times.

In line with policy to continually develop and improve its products, Moffat Limited reserves the right to change specifications and design without notice.



Copyright Moffat Ltd.
UK.BS.2026

an Ali Group Company



The Spirit of Excellence