

ELECTRIC RANGE STATIC OVEN 900mm - SOLID TOP

E570

- Heavy-duty construction
- 10.8kW solid hot plate
- 750mm x 570mm cooking area
- Four independent heating zones (2.7kW)
- 16mm thick 16Mo3 chrome moly steel plate
- GN 2/1 6.5kW electric static oven
- Drop down door
- Rear rollers
- Stainless steel exterior
- Easy clean
- Easy service
- Fully modular



E570

Overall Construction

- Galvanized steel chassis
- Welded hob with one-piece formed 2.0mm 304 stainless steel top
- Hob sides 1.2mm 304 stainless steel
- Splashback 1.2mm stainless steel
- Oven sides 0.9mm 304 stainless steel
- Vitreous enamelled hob control panel
- 63mm dia. heavy-duty 1.2mm 304 stainless steel adjustable legs at front and two rollers at rear

Cooktop

- 16mm thick 16Mo3 chrome moly plate
- Four radiant heating elements under plate
- Four independent heating zones
- Aluminised steel internal construction

Oven

- Fully welded and vitreous enamelled oven liner
- GN 2/1 capacity with 4 position racking
- Heavy-duty easy remove heavy wire chrome rack supports
- Cast iron even heat oven sole plate
- 6.5kW heating elements
- Drop down door
- 0.9mm 304 stainless steel door outer
- 1.0mm vitreous enamelled door inner
- High density fibreglass insulated
- Supplied with two chrome wire oven racks

Controls

- Large easy use control knob - heat resistant reinforced
- Easy view control settings on knob

Cooktop

- Four 6 position switches for heating zones temperature control
- Power indicator light for each element control

Oven

- Separate temperature and top heat power regulation controls
- 50-320°C thermostatic control
- Lo-Hi top heat control
- Indicator lights for power and heating

Cleaning and Servicing

- All models with easy clean stainless steel external finish
- Removable stainless steel spill tray
- Removable oven racking and sole plate
- Easy clean vitreous enamel oven and door inner
- Access to all parts from front of unit

ELECTRIC RANGE STATIC OVEN 900mm - SOLID TOP

E570

Specifications

Cooktop

16mm thick 16Mo3 steel hot plate
750mm x 520mm plate area.
Four 2.7kW radiant heating elements under plate

Oven

4.5kW bottom heat element
2.0kW top heat element

Electrical requirements

E570 17.3 kW

Electrical connection

17.3 kW max
400-415Vac, 50/60Hz, 3P+N+E
L1 30.8A max
L2 22.4A max
L3 22.4A max

Oven Dimensions

Width 665mm
Depth 590mm
Height 400mm
Rack size 650mm x 600mm
Rack positions 4

Dimensions

Width 900mm
Depth 812mm
Height 915mm
Incl. splashback 1085mm

Nett weight

195kg

Packing data

1.03m³, 260kg
Width 945mm
Depth 870mm
Height 1255mm

Options

Adjustable feet at rear
Castors

E570

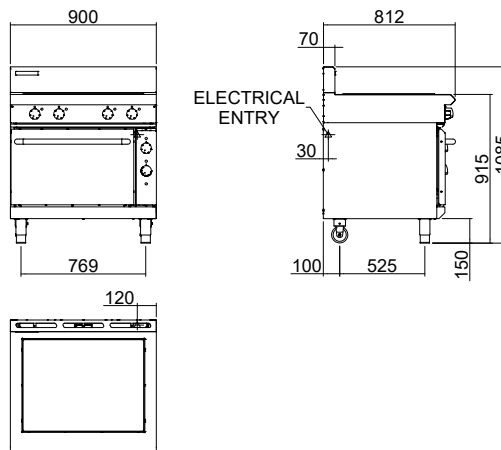

moffat.com.au
moffat.co.nz

Australia
moffat.com.au

Moffat Pty Limited

Victoria/Tasmania
740 Springvale Road
Mulgrave, Victoria 3170
Telephone +613-9518 3888
Facsimile +613-9518 3833
vsales@moffat.com.au

New South Wales
Telephone +612-8833 4111
nswsales@moffat.com.au

South Australia
Telephone +613-9518 3888
vsales@moffat.com.au

Queensland
Telephone +617-3630 8600
qldsales@moffat.com.au

Western Australia
Telephone +618-9413 2400
wasales@moffat.com.au

New Zealand
moffat.co.nz

Moffat Limited

Rolleston
45 Illinois Drive
Izone Business Hub
Rolleston 7675
Telephone +64 3-983 6600
Facsimile +64 3-983 6660
sales@moffat.co.nz

Auckland
Telephone +64 9-574 3150
sales@moffat.co.nz



In line with policy to continually develop and improve its products, Moffat Limited reserves the right to change specifications and design without notice.

© Copyright Moffat Ltd
AN.BSE.01.24

an Ali Group Company



The Spirit of Excellence