

ELECTRIC RANGE CONVECTION OVEN 900mm - SOLID TOP

E576

- Heavy-duty construction
- 10.8kW solid hot plate
- 750mm x 570mm cooking area
- Four independent heating zones (2.7kW)
- 16mm thick 16Mo3 chrome moly steel plate
- GN 2/1 6.6kW electric convection oven
- Drop down door
- Rear rollers
- Stainless steel exterior
- Easy clean
- Easy service
- Fully modular



E576

Overall Construction

- Galvanized steel chassis
- Welded hob with one-piece formed 2.0mm 304 stainless steel top
- Hob sides 1.2mm 304 stainless steel
- Splashback 1.2mm 304 stainless steel
- Front panels and oven sides 0.9mm 304 stainless steel
- Vitreous enamelled hob control panel
- 63mm dia. heavy-duty 1.2mm 304 stainless steel adjustable legs at front and two rollers at rear

Cooktop

- 16mm thick 16Mo3 chrome moly plate
- Four radiant heating elements under plate
- Four independent heating zones
- Aluminised steel internal construction

Oven

- Fully welded and vitreous enamelled oven liner
- GN 2/1 capacity with 4 position racking
- Heavy-duty easy remove heavy wire chrome rack supports
- Cast iron even heat oven sole plate
- 6.5kW heating elements
- 100W heavy-duty motor
- 200mm diameter heavy-duty circulation fan
- Drop down door
- 0.9mm 304 stainless steel door outer
- 1.0mm vitreous enamelled door inner
- High density fibreglass insulated
- Supplied with two chrome wire oven racks

Controls

- Large easy use control knob - heat resistant reinforced
- Easy view control settings on knob

Cooktop

- Four 6 position switches for heating zones temperature control
- Power indicator light for each element control

Oven

- 50-320°C thermostatic control
- Indicator lights for power and heating
- Fan and elements automatic off when doors open

Cleaning and Servicing

- All models with easy clean stainless steel external finish
- Removable stainless steel spill tray
- Removable oven racking and sole plate
- Easy clean vitreous enamel oven and door inner
- Access to all parts from front of unit

ELECTRIC RANGE CONVECTION OVEN 900mm - SOLID TOP

E576

Specifications

Cooktop

16mm thick 16Mo3 steel hot plate
750mm x 520mm plate area.
Four 2.7kW radiant heating elements under plate

Oven

4.5kW bottom heat element
2.0kW top heat element

Oven Fan Motor

100W

Electrical requirements

E576 17.3kW

Electrical connection

17.3kW max
400-415Vac, 50/60hz, 3P+N+E
L1 30.8A max
L2 22.4A max
L3 22.4A max

Oven Dimensions

Width 665mm
Depth 590mm
Height 400mm
Rack size 650mm x 600mm
Rack positions 4

Dimensions

Width 900mm
Depth 812mm
Height 915mm
Incl. splashback 1085mm

Nett weight

198kg

Packing data

1.03m³, 263kg
Width 945mm
Depth 870mm
Height 1255mm

Options

Adjustable feet at rear
Joining caps
Castors

E576

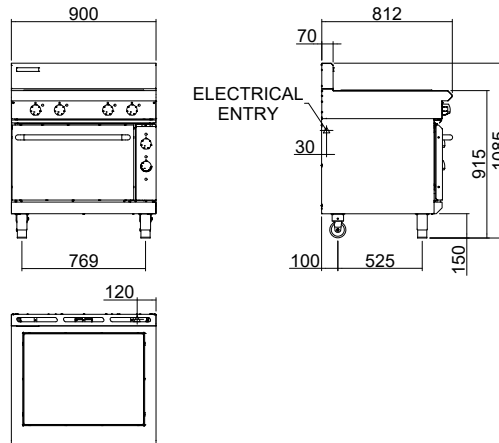

moffat.com.au
moffat.co.nz

Australia
moffat.com.au

Moffat Pty Limited

Victoria/Tasmania
740 Springvale Road
Mulgrave, Victoria 3170
Telephone +613-9518 3888
Facsimile +613-9518 3833
vsales@moffat.com.au

New South Wales
Telephone +612-8833 4111
nswsales@moffat.com.au
South Australia
Telephone +613-9518 3888
vsales@moffat.com.au

Queensland
Telephone +617-3630 8600
qldsales@moffat.com.au

Western Australia
Telephone +618-9413 2400
wasaless@moffat.com.au

New Zealand
moffat.co.nz

Moffat Limited

Rolleston
45 Illinois Drive
Izone Business Hub
Rolleston 7675
Telephone +64 3-983 6600
Facsimile +64 3-983 6660
sales@moffat.co.nz

Auckland
Telephone +64 9-574 3150
sales@moffat.co.nz



In line with policy to continually develop and improve its products, Moffat Limited reserves the right to change specifications and design without notice.

© Copyright Moffat Ltd
AN.BSE.01.24

an Ali Group Company



The Spirit of Excellence