

# ELECTRIC GRIDDLE 450mm

EP513-B, EP513-CB, EP513-LS

- Heavy-duty thermostatic electric griddle
- 20mm thick griddle plate
- Ribbed plate options
- Mirror chromed plate options
- Top weld sealed plates
- 6kW heating elements
- 2 models of base unit
- Rear rollers
- Stainless steel exterior
- Easy clean
- Easy service
- Fully modular



EP513-LS

## Overall Construction

### Griddle

- 20mm thick machined top plates standard
- Optional ribbed plate sections
- Optional mirror finish hard chrome plates
- 2.5mm thick stainless steel splash guards sides and rear
- 2.5mm thick grease channel
- Single temperature control zone
- Welded hob surround with 1.5mm stainless steel bull nose
- Side panels 1.2mm stainless steel
- Splashback 1.2mm stainless steel
- Enamelled control panel
- Stainless steel grease drawer
- Overlapping finish at front and rear of plate for easy clean

### Bench mount (supplied as -B model)

- Four 63mm dia. heavy-duty 1.2mm stainless steel bench legs with adjustable feet
- Adjustable height 80mm - 105mm

### Cabinet base (supplied as -CB model)

- Fully modular for match suite finish
- Double skin 0.9mm stainless steel interior and exterior
- Optional GN 1/1 4 position racking kit
- 63mm dia. heavy-duty 1.2mm stainless steel legs with two adjustable feet at front and two rollers at rear

### Leg stand (supplied as -LS model)

- Fully modular for matched suite finish
- Framed top for connection to Griddle
- 63mm dia. heavy-duty 1.2mm stainless steel legs with two adjustable feet at front and two rollers at rear
- Fully modular framed stand shelf with 0.9mm stainless steel finish
- Quick assembly design

### Controls

- 50-300°C thermostat
- Single temperature control zone
- Large easy use control knob - heat resistant reinforced
- Easy view control settings on knob
- Indicator lights for power and heating
- Over-temperature safety cut-out

### Cleaning and Servicing

- All models with easy clean stainless steel external finish
- Plate is finished front and rear with overlap construction to remove cleaning traps
- Control service through front of unit

# ELECTRIC GRIDDLE 450mm

EP513-B, EP513-CB, EP513-LS

## Specifications

### Elements

3 x 2kW stainless steel sheathed heating elements

### Electrical requirements

6kW  
230-240Vac, 50/60Hz, 1P+N+E, 25A

### Plate

Cooking surface 442mm x 530mm, 2343cm<sup>2</sup>

## Dimensions

### Bench models

Width 450mm  
Depth 812mm  
Height 315mm  
Incl. splashback 485mm

### All models (excluding Bench model)

Width 450mm  
Depth 812mm  
Height 915mm  
Incl. splashback 1085mm

## Nett weight

### Bench models

78kg

### Leg Stand models

93kg

### Cabinet Base models

104kg

## Packing data

### Bench models

0.28m<sup>3</sup>, 113kg  
Width 490mm  
Depth 860mm  
Height 665mm

### Leg Stand models

0.529m<sup>3</sup>, 133kg  
Width 490mm  
Depth 860mm  
Height 1255mm

### Cabinet Base models

0.529m<sup>3</sup>, 144kg  
Width 490mm  
Depth 860mm  
Height 1255mm

## Options

Adjustable feet at rear

Joining caps

Castors

Ribbed plate options

Mirror chromed plate options

E513-B

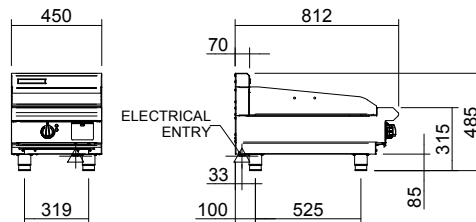

E513-LS

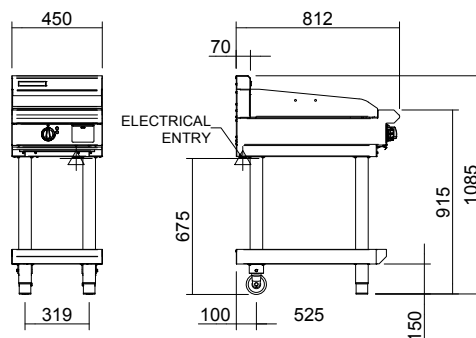

E513-CB

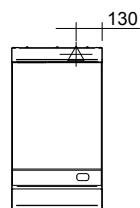
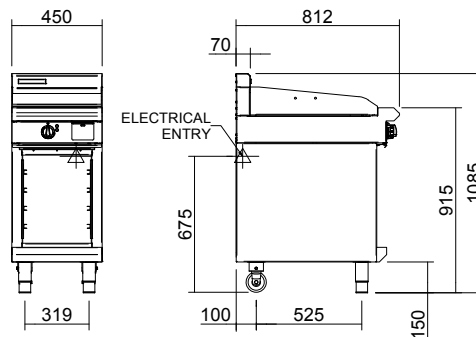

www.blue-seal.co.uk

United Kingdom

blue-seal.co.uk

Blue Seal Limited

Unit 67

Gravelly Business Park

Gravelly

Birmingham B24 8TQ

England

Telephone 0121-327 5575

Facsimile 0121-327 9711

sales@blue-seal.co.uk

Australia

moffat.com.au

Moffat Pty Limited

740 Springvale Road

Mulgrave

Victoria 3170

Australia

Telephone +613-9518 3888

Facsimile +613-9518 3833

vsales@moffat.com.au

New Zealand

moffat.co.nz

Moffat Limited

45 Illinois Drive

Izone Business Hub

Rolleston 7675

New Zealand

Telephone +64 3-983 6600

Facsimile +64 3-983 6660

sales@moffat.co.nz

International

moffat.com

international@moffat.co.nz



ISO9001  
Quality  
Management  
Standard

Designed and manufactured by



ISO9001

All Blue Seal products are designed and manufactured by Moffat using the internationally recognised ISO9001 quality management system, covering design, manufacture and final inspection, ensuring consistent high quality at all times.

In line with policy to continually develop and improve its products, Moffat Limited reserves the right to change specifications and design without notice.



Copyright Moffat Ltd.  
UK.BS.2026

an Ali Group Company



The Spirit of Excellence