

## MAR Series Scale Ice Maker – up to 650kg

**MAR 106 AS** Scale Ice thickness – 1-2mm, residual water content 2%



Scale ice - 1-2mm, residual water content 2%



Note: Ice production rate is measured with the water temperature at 10°C and an ambient temperature of 21°C.

- Up to 650kg daily production capacity
- Scale ice machine, in “compact system” version, built in unit
- Head only ice maker, requires a separate storage bin to store ice product\*
- Air Cooled version
- AISI304 Stainless steel evaporating drum and ice scraper blade
- Low-water sensor protection
- Drive motor / gear reducer with V-Belt drive
- Plug and work technology
- On/off manual switch, with weekly programmable timer
- Water in / ice out concept limits excess energy, water and time wastage
- Agion Technology resists the growth of microbes and the development of unpleasant odours

- Simple, reliable electromechanic controls
- Resistant stainless steel exterior
- Easy access front condenser air filter
- External indicator lights to show operation status

### Recommended Storage Bins

- UBH 1100 – Upright storage bin with 553kg storage capacity
- SIS 700 – Ice shuttle storage system – 318kg + 73kg storage

### MAR Series Scale Ice Maker – up to 650kg

#### MAR 106 AS

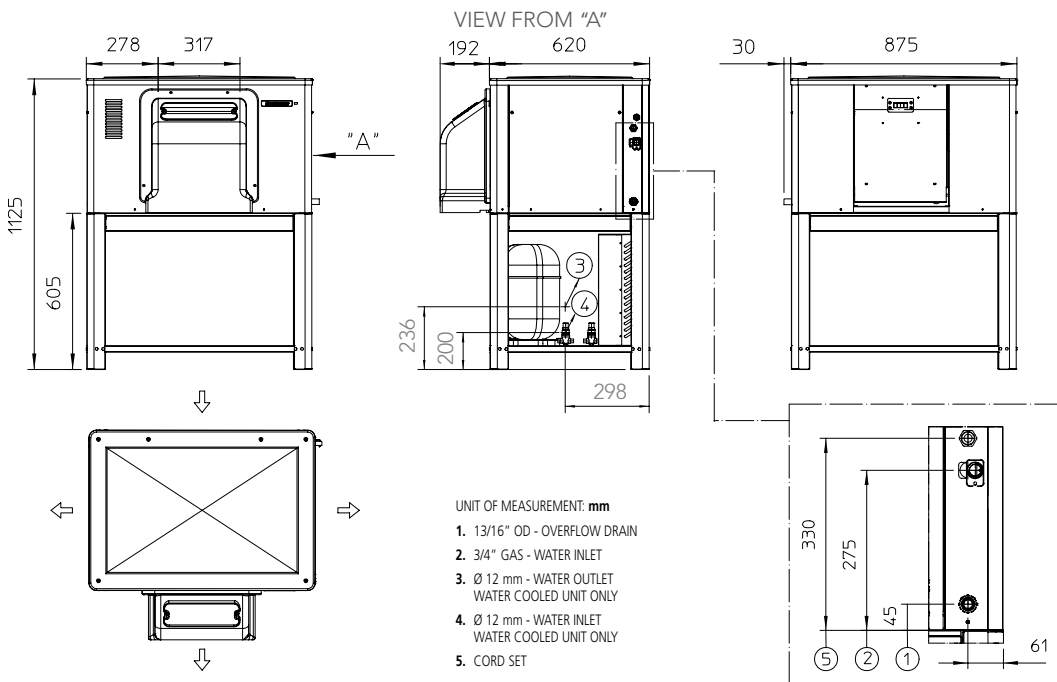

moffat.com.au

Australia  
Moffat Pty Limited  
Victoria/Tasmania  
740 Springvale Road  
Mulgrave, Victoria 3170  
Telephone 03-9518 3888  
Facsimile 03-9518 3833  
vsales@moffat.com.au

New South Wales  
Telephone 02-8833 4111  
nswsales@moffat.com.au

South Australia  
Telephone 03-9518 3888  
vsales@moffat.com.au

Queensland  
Telephone 07-3630 8600  
qldsales@moffat.com.au

Western Australia  
Telephone 08-9413 2400  
wasales@moffat.com.au

#### Ice production per 24 hours

Ambient temperature / Water temperature

| 10°C / 10°C | 21°C / 10°C | 32°C / 21°C |
|-------------|-------------|-------------|
| 1mm: 700    | 1mm: 650    | 1mm: 580    |
| 2mm: 630    | 2mm: 585    | 2mm: 522    |

#### Dimensions

Width: 905mm  
Depth: 812mm  
Height: 1125mm  
Nett weight: 188kg  
Packed weight: 205kg

#### Water consumption

Air cooled version: 24.2 litres per hour

#### Electrical rating

Air cooled version: 400-415V, 3P+N+E, 50Hz, 3500W,  
16A  
No. Circuit wire: 5  
Compressor: 4450W  
Energy consumption: 80kW/24hr

#### Refrigerant type

R404A

#### Installation distance from wall

Rear 100mm  
Sides 150mm  
Operating requirement air temperature 10-43°C

#### Water connection requirements

Inlet connection: R 3/4"  
Cold water: 5-35°C  
Pressure: 100-500kPa  
Water outlet connection: Ø3/4"

#### Important Notice:

Models and specifications are subject to change without notice. This spec sheet is meant for commercial purpose only. For technical documentation please refer to our service manuals.



© Copyright Moffat Ltd  
AU.SM.2201