

# Proveno 4G Electric Combi Jacketed Kettle

## Proveno 4G Combi 80E (4224304)

### Standard Features

- Proveno kettle with integrated mixer
- Electric heated version
- Stepless mixing speed 15-140 rpm/min, auto-reverse
- Elevated control pillar with guiding touch panel
- Safety grid lid
- Audiovisual signals for user
- Multi-function timer
- ProTemp – real time temperature control, food and jacket temperature separately controlled
- Delta T cooking – temperature of jacket rises accordingly when food temperature rises
- Programming on screen, unlimited number of programs and program phases, favourite pages, wash programs
- Automatic measured water filling
- Electric tilting - tilting height 600mm
- Tilting while mixing function
- Auto tilt-back
- Measuring stick
- Retractable handshower
- Strainer plate
- USB Port on control panel
- Diagnostics for maintenance
- Unit shown includes free standing floor kit - other options available



Please refer to Moffat price list for options and accessories

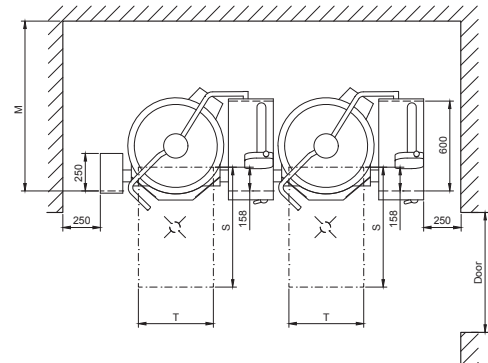
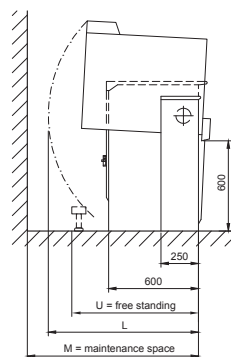
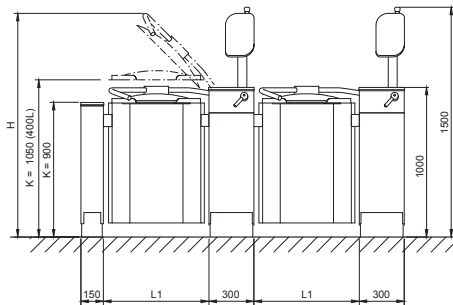

### Technical Data

Net Volume 80 L  
Spare Volume 11 L  
Gross Volume 91 L

#### Dimensions

Width 1154mm  
Height 1535mm  
Depth 750mm

#### Connections

Water Cold ø15mm  
Hot ø15mm

Electrical Power 22kW  
Voltage 400-415V,  
3P+N+E 50/60Hz  
AMP 40A

Total Heat 20kW  
Load Latent 0.8 kW,  
Sensible 3.4 kW

Waste By kitchen contractor  
Nett Weight 230 kg

| Model | L1 mm | H mm | L mm | M mm | U mm | T mm | Door mm |
|-------|-------|------|------|------|------|------|---------|
| 80E   | 704   | 1745 | 1010 | 1235 | 890  | 500  | 800     |

**Australia**  
[moffat.com.au](http://moffat.com.au)  
**Moffat Pty Limited**  
740 Springvale Road  
Mulgrave  
Victoria 3170  
Australia  
Telephone +613-9518 3888  
Facsimile +613-9518 3833  
[vsales@moffat.com.au](mailto:vsales@moffat.com.au)

**New Zealand**  
[moffat.co.nz](http://moffat.co.nz)  
**Moffat Limited**  
45 Illinois Drive  
Izone Business Hub  
Rolleston 7675  
New Zealand  
Telephone +64 3-983 6600  
Facsimile +64 3-983 6660  
[sales@moffat.co.nz](mailto:sales@moffat.co.nz)



Disclaimer: All unit capacities are based on subjective testing. Moffat accepts no liability for production values. In line with policy to continually develop and improve its products, Moffat Limited reserves the right to change specifications and design without notice.

© Copyright Moffat Ltd  
AN-MET-S-2001