

# Viking 4G Steam Combi Jacketed Kettle

## Viking 4G COMBI 400S (4224234)

### Standard Features

- Kettle with integrated mixer
- 400 litre capacity
- Steam heated version
- Elevated control pillar with selected features
- Mixing speed control 20-110 rpm/min, autoreverse
- Two mixing programs
- Electric tilting – tilting height 600mm
- Auto tilt-back
- Safety grid lid
- Measuring stick
- Retractable handshower
- Strainer plate
- Stainless steel construction
- Unit shown includes free standing floor kit - other options available

Please refer to Moffat price list for options and accessories

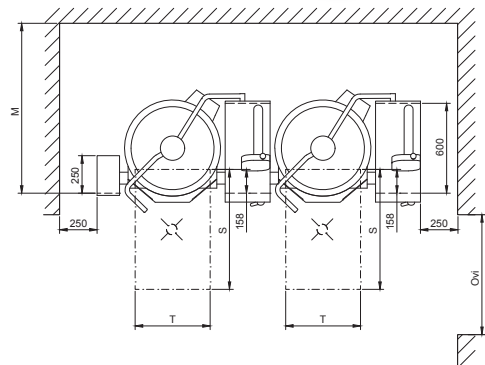
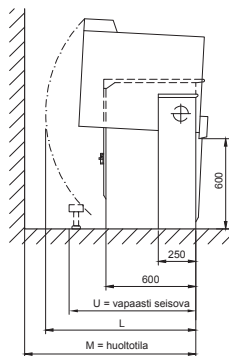
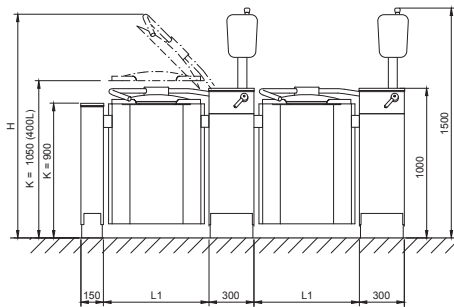

### Technical Data

Net Volume 400 L  
Spare Volume 33 L  
Gross Volume 433 L

#### Dimensions

Width 1560mm  
Height 1500mm  
Depth 1073mm

#### Connections

Water Cold ø15mm  
Hot ø10mm  
Steam R 1¼" 115 kg/hr  
Cond. Outlet R ¾"

Electrical Power 4.8 kW  
Voltage 400-415V, 3P+N+E 50/60Hz  
AMP 25A  
Total Heat 57.2 kW  
Load Latent 2.1 kW, Sensible 11.5 kW  
Waste By kitchen contractor  
Nett Weight 470 kg

Model	L1 mm	H mm	L mm	M mm	U mm	T mm	Door mm
<b>400S</b>	<b>1110</b>	<b>2110</b>	<b>1280</b>	<b>1320</b>	<b>1010</b>	<b>600</b>	<b>1010</b>

**Australia**  
[moffat.com.au](http://moffat.com.au)  
**Moffat Pty Limited**  
740 Springvale Road  
Mulgrave  
Victoria 3170  
Australia  
Telephone +613-9518 3888  
Facsimile +613-9518 3833  
[vsales@moffat.com.au](mailto:vsales@moffat.com.au)

**New Zealand**  
[moffat.co.nz](http://moffat.co.nz)  
**Moffat Limited**  
45 Illinois Drive  
Izone Business Hub  
Rolleston 7675  
New Zealand  
Telephone +64 3-983 6600  
Facsimile +64 3-983 6600  
[sales@moffat.co.nz](mailto:sales@moffat.co.nz)



Disclaimer: All unit capacities are based on subjective testing. Moffat accepts no liability for production values. In line with policy to continually develop and improve its products, Moffat Limited reserves the right to change specifications and design without notice.

© Copyright Moffat Ltd  
AN-MET-S-2001