

Electric Range Static Oven 900mm - Solid Top

RNLB8114E



RNLB8114E

- Heavy-duty construction
- 10.8kW solid hot plate
- 750mm x 570mm cooking area
- Four independent heating zones (2.7kW)
- 16mm thick 16Mo3 chrome moly steel plate
- GN 2/1 6.5kW electric static oven
- Drop down door
- Stainless steel exterior
- Black vitreous enamel finish to front panels
- Easy clean
- Easy service
- Fully modular

OVERALL CONSTRUCTION

- Galvanized steel chassis
- Welded hob with one-piece formed 2.0mm 304 stainless steel top
- Splashback and hob sides 1.2mm 304 stainless steel
- Front panels black vitreous enamel finish
- 150mm legs in 63mm dia. heavy-duty 1.2mm 304 stainless steel with adjustable feet

COOKTOP

- 16mm thick 16Mo3 chrome moly plate
- Four radiant heating elements under plate
- Four independent heating zones
- Aluminised steel internal construction

OVEN

- Fully welded and vitreous enamelled oven liner
- GN 2/1 capacity with 4 position racking
- Heavy-duty easy remove heavy wire chrome rack supports
- Cast iron even heat oven sole plate
- 6.5kW heating elements
- Welded frame drop down door with heavy-duty spring hinge system
- 0.9mm 304 stainless steel door outer
- 1.0mm press formed vitreous enamelled door inner
- High density fibreglass insulated
- Stay cool stainless steel door handle with cast metal handle mounts
- Supplied with two chrome wire oven racks

CONTROLS

- Four 6 position switches for heating zones temperature control
- Easy view control settings on knob

COOKTOP

- Cast iron hot plate elements with 6 heat position switch
- Power indicator light for each element control

OVEN

- Separate temperature and top heat power regulation controls
- 50-320°C thermostatic control
- Lo-Hi top heat control
- Indicator lights for power and heating

CLEANING AND SERVICING

- All models with easy clean stainless steel external finish
- Removable stainless steel spill tray
- Removable oven racking and sole plate
- Easy clean vitreous enamel oven and door inner
- Door hinge spring adjustable on unit (door outer removed)
- Door disengages for lift off removal and increased service access
- Access to all parts from front of unit

Series Options

RNLB - Low back models

RNB - 215mm splashback option

Waldorf Bold

Electric Range Static Oven 900mm - Solid Top

RNLB8114E

RNLB8114E

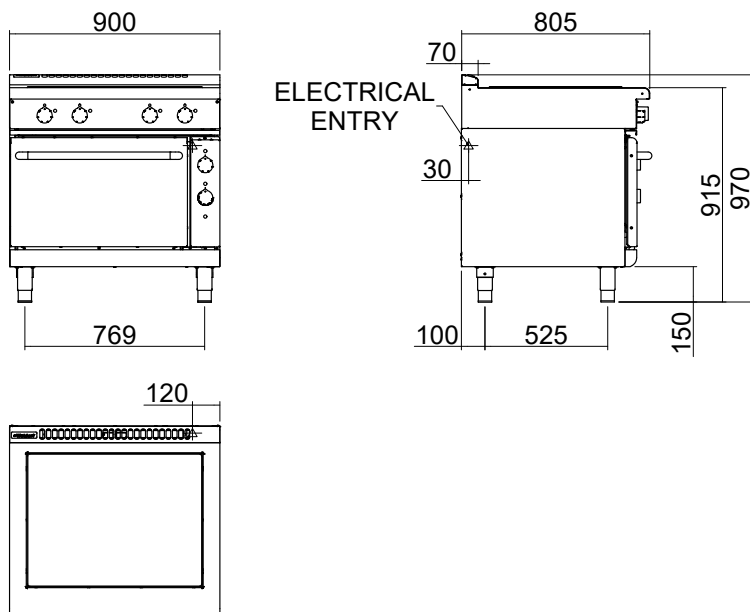

SPECIFICATIONS

Cooktop

16mm thick 16Mo3 steel hot plate
750mm x 520mm plate area.

Four 2.7kW radiant heating elements under plate

Oven

4.5kW bottom heat element
2.0kW top heat element

Electrical requirements

RNLB8114E 17.3kW

Electrical connection

17.3kW max.
400-415Vac, 50/60Hz, 3P+N+E,
L1 30.8A max.
L2 22.4A max.
L3 22.4A max.

Oven Dimensions

Width 665mm
Depth 650mm
Height 400mm
Rack size 650mm x 600mm
Rack positions 4

Electrical connection

130mm from RH side, 30mm from rear,
and 675mm from floor

Dimensions

Width 900mm
Depth 805mm
Height 915mm
Incl. low back 970mm
Incl. splashback option 1130mm

Nett weight

198kg

Packing data

1.03m³, 263kg
Width 945mm
Depth 870mm
Height 1255mm

OPTIONS AT EXTRA COST

Castors
Plinth mounting

MOFFAT

moffat.com.au
moffat.co.nz

Australia

moffat.com.au

Moffat Pty Limited

Victoria/Tasmania
740 Springvale Road
Mulgrave, Victoria 3170
Telephone +613-9518 3888
Facsimile +613-9518 3833
vsales@moffat.com.au

New South Wales
Telephone +612-8833 4111
nswsales@moffat.com.au

South Australia
Telephone +613-9518 3888
vsales@moffat.com.au

Queensland
Telephone +617-3630 8600
qldsales@moffat.com.au

Western Australia
Telephone +618-9413 2400
wasales@moffat.com.au

New Zealand

moffat.co.nz

Moffat Limited

Rolleston
45 Illinois Drive
Izone Business Hub
Rolleston 7675
Telephone +64 3-983 6600
Facsimile +64 3-983 6660
sales@moffat.co.nz

Auckland
Telephone +64 9-574 3150
sales@moffat.co.nz



ISO9001
Quality
Management
Standard

Designed and manufactured by



ISO9001

All Waldorf Bold products are designed and manufactured by Moffat using the internationally recognised ISO9001 quality management system, covering design, manufacture and final inspection, ensuring consistent high quality at all times.

In line with policy to continually develop and improve its products, Moffat Limited reserves the right to change specifications and design without notice.

© Copyright Moffat Ltd
AN.WBD.S.01.24

an Ali Group Company



The Spirit of Excellence