

SINTESI 60G, SINTESI 80G, SINTESI 120G, SINTESI 160G, SINTESI 200G

Spiral Mixers

Product Features

- Heavy duty painted steel structure.
- Stainless steel header top cover.
- High resistance stainless steel spiral and breaking bar.
- Supplied on wheels with adjustable feet for added stability
- High-performance belt drive and dedicated high-power motors for bowl and spiral rotation.
- 7" touch screen control panel for setting dough times for each speed.
- The change from the first to the second mixing speed and the stopping of the machine happens automatically.
- Possibility of pulse-controlled rotation of the bowl, with open guard, to facilitate emptying.
- Possibility to reverse the bowl rotation in first speed.



SINTESI 60G

Sottoriva is a leading Italian manufacturer of machines and lines for the bread and pastry industries. Established in 1941, Sottoriva offers a comprehensive range of heavy duty equipment to suit from small bakeries right through to large industrial installations, all manufactured to the highest standards to ensure many years of optimal performance. The Sottoriva equipment range includes spiral, fork and double arm dough mixers, removable bowl mixers, automatic roll divider / rounders, fully automated bread roll production lines, fully automated bread production lines and a range of specialized equipment for the craft baker. World renowned for quality equipment, optimal performance and superior reliability, Sottoriva Technology can certainly provide the future for your bakery.

SINTESI 60G, SINTESI 80G, SINTESI 120G, SINTESI 160G, SINTESI 200G Sprial Mixers

Model	Dimensions (mm)					Weight (kg)	Kilowatt (kW)	Dough Capacity (kg)	Flour Capacity (kg)
	Width (A)	Depth (B)	Height (C)	Height (D)	Bowl Width (E)				
SINTESI 60G	450	1197	1348	832	600	362	4.55	60	39
SINTESI 80G	450	1280	1348	832	700	378	4.55	80	52
SINTESI 120G	500	1363	1343	855	800	462	6.05	120	84
SINTESI 160G	550	1551	1565	960	900	645	8.05	160	103
SINTESI 200G	550	1551	1565	1000	900	654	11.55	200	129

Electrical Requirements:

400-415V, 3P+E, 50Hz

Must be installed on an electrical circuit that includes "D-Curve" circuit breakers and "B-Type" RCD protection.

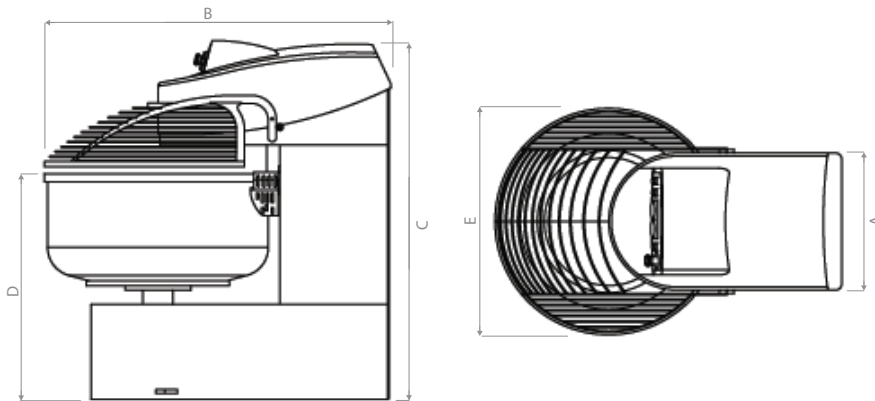

moffat.com.au

moffat.co.nz

Australia

moffat.com.au

Moffat Pty Limited

Victoria/Tasmania

740 Springvale Road

Mulgrave, Victoria 3170

Telephone +613-9518 3888

Facsimile +613-9518 3833

vsales@moffat.com.au

New South Wales

Telephone +612-8833 4111

nswsales@moffat.com.au

South Australia

Telephone +613-9518 3888

vsales@moffat.com.au

Queensland

Telephone +617-3630 8600

qldsales@moffat.com.au

Western Australia

Telephone +618-9413 2400

wasales@moffat.com.au

New Zealand

moffat.co.nz

Moffat Limited

Rolleston

45 Illinois Drive

Izone Business Hub

Rolleston 7675

Telephone +64 3-983 6600

Facsimile +64 3-983 6600

sales@moffat.co.nz

Auckland

Telephone +64 9-574 3150

sales@moffat.co.nz



In line with policy to continually develop and improve its products, Moffat Limited reserves the right to change specifications and design without notice. This specification sheet is meant for commercial purpose only. For technical documentation please refer to our service manuals.

© Copyright Moffat Ltd
ANS.10.24

an Ali Group Company



The Spirit of Excellence