

WD-12S COMBINATION PASSTHROUGH DISHWASHER

STANDARD FEATURES:

- Washes up to 100 baskets per hour
- 5.5 litres per cycle water consumption
- 100 litre wash tank volume
- Adjustable water pressure to easily switch between normal dishwashing and pot washing
- Large useable wash chamber –
W 1220mm x D 620mm x H 600mm
- Fits two 600mm x 500mm baskets
- Unique hood designed for steam to escape at the back of machine
- 3 Cycle times - 72 / 102 / 312 seconds (adjustable)
- Electronic control panel with event log recording for diagnostics and trouble shooting
- Automatic cleaning program
- Self-draining wash arms for optimum wash results
- Automatic hood lift
- Corner or in-line installation
- Detergent and rinse aid pumps for liquid detergent
- Drain pump
- Break Tank to help sites with low water pressure.
- Supplied with 3 high quality dish racks for cups & plates.
- Options include - Auto Start and EcoFlow (heat recovery system)
- Can be paired with a WD-PRM7 to remove the need for Pre-rinsing dishes.

TECHNICAL INFORMATION:

Dimensions

Width: 1295mm
Depth: 815mm
Height: 1695mm

Water

Hot water temperature: 55-70°C
Hot water connection: R1/2" Direct
Pressure: 180-350kPa
Flow: 12 litres per min
Water quality (Hardness): 2-7odH

Waste

Drain hose connection point

Electrical

3P+N+E 400-415V 50/60Hz
18kW 32A Cordset supplied

Refer operator manual for complete installation instructions.

Upgrades and options are available, please contact Moffat for more details.

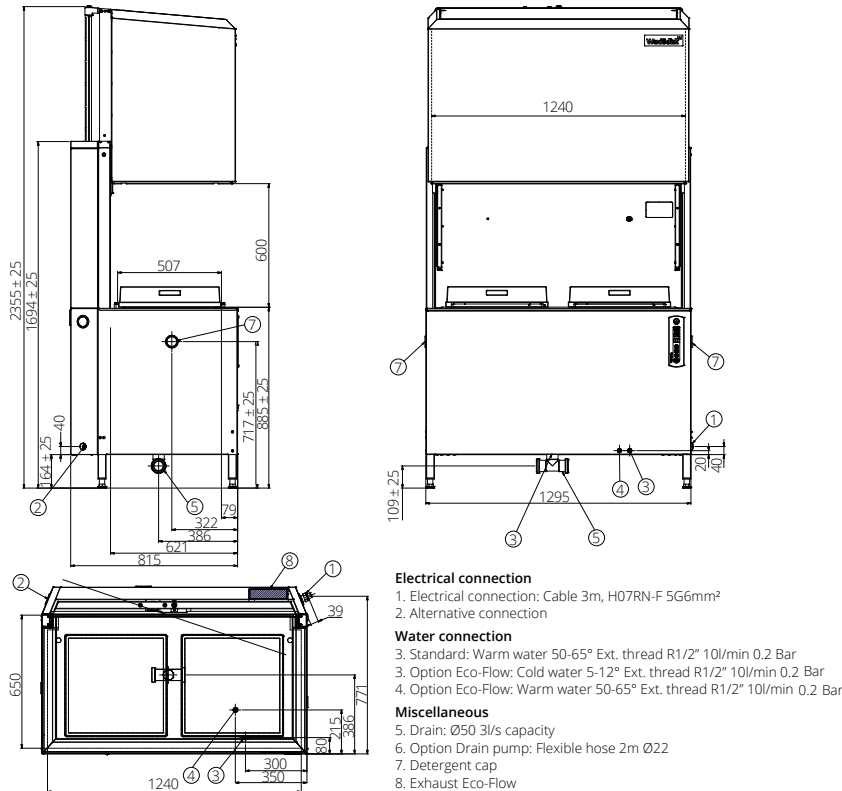

Australia
moffat.com.au
Moffat Pty Limited
740 Springvale Road
Mulgrave
Victoria 3170
Australia
Telephone +613-9518 3888
Facsimile +613-9518 3833
vsales@moffat.com.au

In line with policy to continually develop and improve its products, Moffat Limited reserves the right to change specifications and design without notice.