

WD-90GR-HC HIGH CAPACITY GRANULE POT WASHER

STANDARD FEATURES:

- High capacity potwasher with granule technology
- 68 GN 1/1 containers per hour capacity (including handling)
- 3.5 to 5 litres per cycle cold water consumption
- 6 levels of wash cycle for varying types of soiled product
- 3kW wash pump with 9kW booster pump
- 5 litres granule capacity
- Unique hexagonal cassette, holds 6 x 1/2 GN or 1/1 GN containers
- Centrifugal spin cycle for fast drying
- Patented dual pump system incorporating granule technology
- Electronic control panel
- Hinged door enables for easy cleaning
- HACCP function
- Includes 1 x pot holder, 1 x hexagonal cassette, 1 x holder for 2/1 GN containers, grids or baking trays and cleaning scraper

Upgrades and options are available, please contact Moffat for more details

TECHNICAL INFORMATION:

Dimensions

Width: 878mm
Depth: 955mm
Height: 1882mm

Water

Hot water temperature: 55-70°C
Hot water connection: R1/2"
Hot water pressure: 250kPa
Cold water temperature: 5-12°C
Cold water connection: R1/2"
Cold water pressure: 100-600kPa
Flow: 15 litres per min
Water quality (Hardness): 2-7odH

Waste

Connection: 50mm dia

Electrical

3P+N+E 400-415V 50/60Hz
11.3kW 20A

Refer operator manual for complete installation instructions

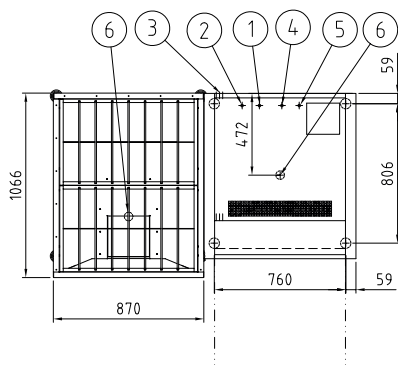
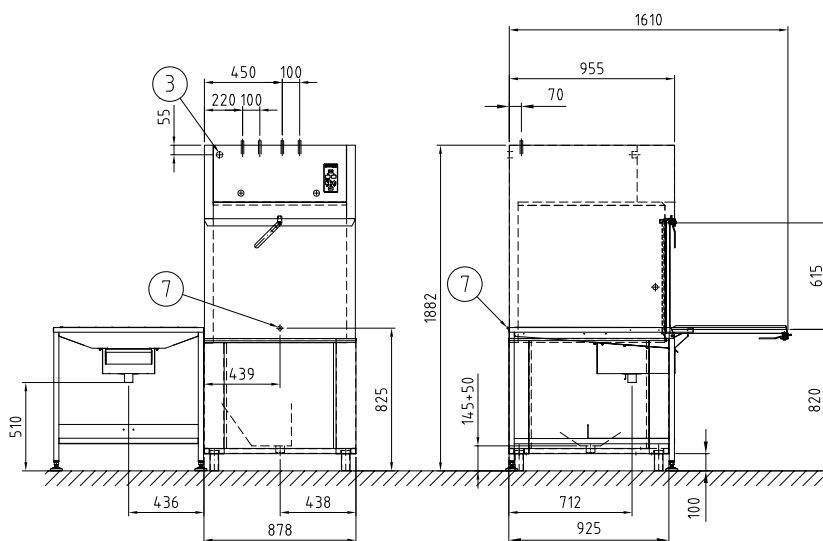

1. Cold water connection 5-12°C, 250-500 kPa, R 1/2" internal thread
2. Hot water connection 55-70°C, 250-500 kPa, R 1/2" internal thread
3. Electrical connection: Electrical heated 400V 3N 11,3kW 20A
Steam heated 400V 3N 2,4kW 16A
4. Steam connection 50-250kPa R 1/2" internal thread, 15-20kg/h
5. Condensate water connection 90-95°C, R1/2" internal thread
6. Drain connection 50 mm, 3l/min
7. Connection for detergent hose

Ventilation requirements 600m³/h

Australia

moffat.com.au

Moffat Pty Limited
740 Springvale Road
Mulgrave
Victoria 3170
Australia
Telephone +613-9518 3888
Facsimile +613-9518 3833
vsales@moffat.com.au

New Zealand

moffat.co.nz

Moffat Limited
45 Illinois Drive
Izone Business Hub
Rolleston 7675
New Zealand
Telephone +64 3-983 6600
Facsimile +64 3-983 6660
sales@moffat.co.nz

In line with policy to continually develop and improve its products, Moffat Limited reserves the right to change specifications and design without notice.