

Single Pan Electric Pressure Multi Pan

JUMP 101P - 100 LITRE



- 100 litre single pan capacity
- 2 x 1/1 GN pan size
- 43dm² cooking surface
- 280mm depth pan
- Pressurised version for faster cooking results
- Multi pan for cooking, frying, braising, grilling, searing, broiling and sous-vide cooking
- Automatic basket lifting
- Automatic water filling system with accuracy of 1 decilitre
- Electromechanical tray tilting at variable speed
- 12" colour touch screen with intuitive controls
- Automatic and manual meal preparation mode with memory for 800 programs with 12 steps
- Multipoint core temperature probe
- Integrated retractable hand shower

Overall Construction

- Base frame with 3mm 304 grade stainless steel
- Frame cover with 304 grade stainless steel
- Tray with 3mm 316 grade stainless steel
- Special sandwich design pan base
- Stainless steel SUPER BLOCK JPX 17 full area heat distribution system
- Robust double insulated cover with automatic lifting function
- Excessive steam exhaust on cover
- Integrated 230V / 16A socket
- Retractable switchboard panel on right pillar allowing integration of multiple pans in a single block

Controls

- Fast base preheating
- Temperature range from 30°C-250°C
- Pressurised cooking at 110°C
- Automatic cover locking / unlocking during pressure cooking
- Automatic overpressure and steam condensation reduction at end of cooking cycle with condensate drainage without water injection

- Accurate sensory measurement of temperature
- Liquid level gauge
- Integrated drainage in the tray bottom with automatic closure
- Preset technological procedures
- Automatic extension of baskets - allows operation with cover closed
- Safety sensor for basket arm detection
- Fault messages shown on display
- Water pressure controller
- HACCP recording
- USB port for data backup

Cleaning and Servicing

- Easy clean stainless steel surface
- Easy services access from front and top sides
- Technical and service information on display

Single Pan Electric Pressure Multi Pan

JUMP 101P - 100 LITRE

Specifications

Dimensions

Width 1293mm
 Depth 950mm
 Height 1050mm

Capacity

100 litre

Nett weight

524kg

Packing data

550kg
 Width 1415mm
 Depth 1010mm
 Height 1150mm

Electrical rating

415V, 3P+N+E, 50Hz, 32A
 Energy consumption: 25.4kW
 Pressure: 0.48 bar

Water connection requirements

Inlet connection: R ¾
 Water outlet connection: Ø 50

Installation conditions

(for precise installation instructions please refer to our installation manual)



moffat.com.au
 moffat.co.nz

Australia

moffat.com.au

Moffat Pty Limited

Victoria/Tasmania
 740 Springvale Road
 Mulgrave, Victoria 3170
 Telephone +613-9518 3888
 Facsimile +613-9518 3833
 vsales@moffat.com.au

New South Wales
 Telephone +612-8833 4111
 nswsales@moffat.com.au

South Australia
 Telephone +613-9518 3888
 vsales@moffat.com.au

Queensland
 Telephone +617-3630 8600
 qldsales@moffat.com.au

Western Australia
 Telephone +618-9413 2400
 wasales@moffat.com.au

New Zealand
 moffat.co.nz

Moffat Limited

Rolleston
 45 Illinois Drive
 Izone Business Hub
 Rolleston 7675
 Telephone +64 3-983 6600
 Facsimile +64 3-983 6660
 sales@moffat.co.nz

Auckland
 Telephone +64 9-574 3150
 sales@moffat.co.nz

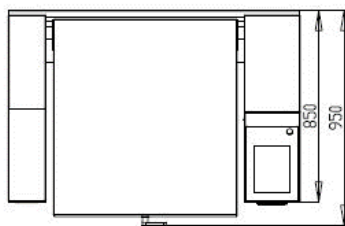
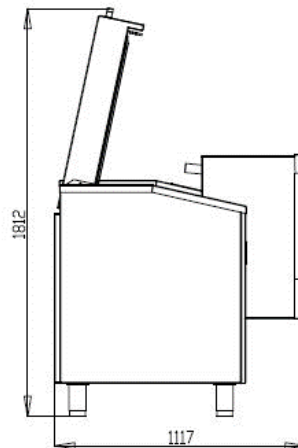
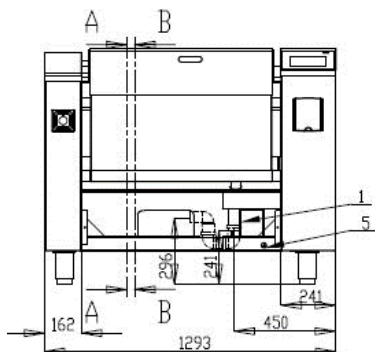

- 1 Drain DN 50
- 2 Water Inlet 3/4"
- 3 Power Connection
- 4 LAN Jack RJ 45
- 5 Equipotential Bonding

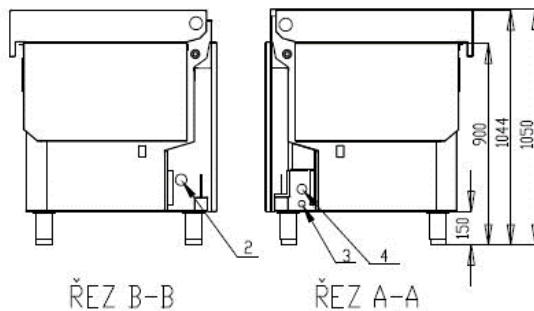

Copyright Moffat Ltd.
 AN.WJ.2022

an Ali Group Company



The Spirit of Excellence